

# TECHNICAL HYDRAULIC HANDBOOK

12<sup>TH</sup> EDITION

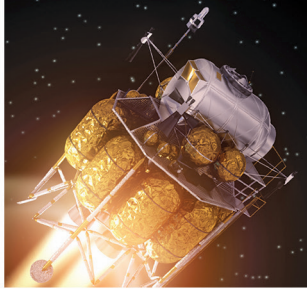

Innovation in Miniature  
**LEE** 

The Lee Company





# Technical Hydraulic Handbook

**12<sup>th</sup> Edition**

**Lee products with  
complete engineering data.**

## **THE LEE COMPANY TECHNICAL CENTER**

2 Pettipaug Road, P. O. Box 424  
Westbrook, Connecticut 06498-0424 U.S.A.

Phone: 860 399-6281  
800 533-7584 (LEE PLUG)

Fax: 860 399-7058 (order entry)  
860 399-7037 (technical information)

## II

# The Lee Company History

A dream, hard work  
and perseverance  
have made  
The Lee  
Company  
a success.

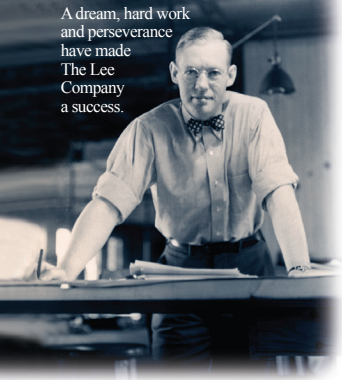

**1948:**  
Leighton Lee II founds  
The Lee Company at  
home in Rocky Hill, CT.

## The Continuing Story

Still a family owned and operated company today, The Lee Company continues to carry out Mr. Lee's legacy. With a strong commitment to quality and performance, the company has flourished due to continuing innovation and is now a world leader in the manufacture of miniature precision fluid control products for the aerospace, high performance racing, oil and gas, automotive and medical/scientific industries.

**1948      Early 1950s      1958      Early 1960s      Late 1960s      Early 1970s**

### Early 1950s:

The Lee Company began to expand by first purchasing a machine shop in Hartford, CT. By 1954, The Lee Company had purchased an additional 88 acres of land in Westbrook, CT which would serve as the future site for The Lee Company headquarters.

### 1958:

The patent for the original Lee Plug was issued. The success of this product line became the foundation for today's extensive line of aerospace and hydraulic product offerings.

### Early 1960s:

The Lohm Laws were introduced. The Lee Company continued to expand with new buildings to allow for in-house manufacturing.

### Late 1960s:

Lee products were in the Lunar Excursion Module and space suits of Apollo 11 when Neil Armstrong and Buzz Aldrin Jr. took their first historic walk on the surface of the moon.

### Early 1970s:

The LIF, a low-pressure solenoid valve, is introduced, eventually leading to the Electro-Fluidic Systems division. The Lee Company publishes the first edition of The Technical Hydraulic Handbook. Sales offices were opened throughout the US and foreign subsidiaries were added in Europe to provide a direct sales force of engineers able to solve customers' problems.

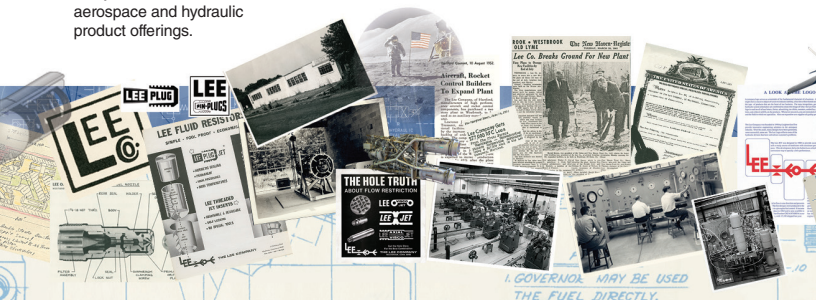

**1990:**

The Lee Company launched the first Lee Hi-Bar Safety Screens, a robust safety screen design manufactured from one-piece of bar stock for last chance protection against rogue contamination.

**1991:**

The Industrial Micro-Hydraulics Division is formed to meet the high-volume production rates and unique quality requirements of the automotive industry.

**1992:**

The Lee Company undergoes a major restructuring to improve responsiveness for customer support, dividing into separate product groups each with their own dedicated engineering department and manufacturing facilities.

**1994:**

The Lee Company began supplying pilot-ing solenoid valves that utilize a Lee Multi-Seal to reduce size and weight for aerospace, oil and gas, and racing industries.

1990

1991

1992

1994

2006

2012

2018

**2006:**

The .250" Zero Leak Chek Valve was introduced, becoming the first of many products utilizing an elastomeric seal for applications in which any leakage is critical.

**2012:**

Standard families of Lee Cheks™, Lee PRIs™ and Lee Floserts® constructed entirely from NACE compliant materials first became available to meet the extreme environments required for deep well drilling and completion equipment.

**2018:**

The Lee Company announces our newest product family, miniature positive displacement pumps



## U.S. Sales Offices

**Westbrook, Connecticut**

Tel: 860 399-6281

**Chicago, Illinois**

Tel: 773 693-0880

**Tampa, Florida**

Tel: 813 287-9293

**Southfield, Michigan**

Tel: 248 827-0981

**Irving, Texas**

Tel: 972 791-1010

**Huntington Beach, California**

Tel: 714 899-2177

**Tacoma, Washington**

Tel: 727 466-7901

## International Sales Offices

**Lee Products Limited – London***Subsidiary/United Kingdom & Ireland*

Tel: +44 1 753-886664

[sales@leeproducts.co.uk](mailto:sales@leeproducts.co.uk)**LEE COMPANY S.A. – Paris***Subsidiary / France, Spain & French speaking Switzerland*

Tel: +33 1 30 649944

[info@leecompany.fr](mailto:info@leecompany.fr)

Toulouse Office:

Tel: +33 567 31 0092

[h.reberga@leecompany.fr](mailto:h.reberga@leecompany.fr)

Madrid Office:

Tel: +34 913 010 572

[pablo.sanchez@leecompany.es](mailto:pablo.sanchez@leecompany.es)**Lee Hydraulische – Frankfurt****Miniaturkomponenten GmbH***Subsidiary / Germany, Austria, Eastern Europe & German speaking Switzerland*

Tel: +49 6196-77369-0

[info@lee.de](mailto:info@lee.de)**Lee SRL. – Milan***Subsidiary / Italy & Italian speaking Switzerland*

Tel: +39 02 43981750

[sales@leesrl.it](mailto:sales@leesrl.it)**The Lee Company****Scandinavia AB – Stockholm***Subsidiary / Denmark, Sweden, Norway & Finland*

Tel: +46 8 579 70170

Helsinki, Finland Office:

Tel: +358 44 0111 246

[sales@theleeco.se](mailto:sales@theleeco.se)**Distributor for Belgium, Netherlands and Luxemburg**

Denis de Ploeg BV

Tel: +31 43 820 0250

[bs.deploeg@ddp.nl](mailto:bs.deploeg@ddp.nl)**Distributor for Australia and New Zealand**

CGB Precision Products Pty. Ltd.

Tel: +61 3 9775 1125

[info@cgb.com.au](mailto:info@cgb.com.au)**Distributor for People's Republic of China, and Hong Kong**

EBS Flow Control, Ltd.

Tel: +86 10 84721177

[info@ebshk.com.cn](mailto:info@ebshk.com.cn)**Distributor for Japan**

Jupiter Corporation

Tel: +81 33 403 1315

[lee-sales@jupiter.co.jp](mailto:lee-sales@jupiter.co.jp)

## **Distributor for Republic of Korea**

Min Sung GC Corporation  
Tel: +82 2 961 7833  
[minsung@minsunggc.com](mailto:minsung@minsunggc.com)

## **Distributor for Taiwan**

Windarc Technology Co. Ltd.  
Tel: +886 9 6307 0609  
[windarc.chen@gmail.com](mailto:windarc.chen@gmail.com)

## **Agent for Brazil**

Trusty Comércio e  
Representações Ltda.  
Tel: +55 12 3132-3418  
[rui@tcr-brazil.com.br](mailto:rui@tcr-brazil.com.br)

## **Agent for Israel**

ENL Engineering & Logistics Ltd.  
Tel: +972 3 549 3644  
[enleng@netvision.net.il](mailto:enleng@netvision.net.il)

## **Agent for India**

Hind Industrial & Mercantile  
Corp. Pvt. Ltd.  
Tel: +91 99204 05099  
[sales@hindco.in](mailto:sales@hindco.in)

## **Agent for Southeast Asia**

Winova Pte Ltd.  
Tel: +65 6425 2116  
[sales@winova.com.sg](mailto:sales@winova.com.sg)

## **THE CONTINUING STORY OF LEE COMPANY INNOVATION**

Since its beginning in 1948, The Lee Company has pioneered the design and development of miniature fluid control components. Under the premise of economically solving problems where existing hardware is either not immediately available, or is too cumbersome, the Lee Company continues to set the standards for fluid control components through innovations developed at our Technical Centers in Essex and Westbrook, Connecticut.

## **ENGINEERING**

The Lee Company story of innovation never ends. We employ more than 1,000 people and maintain a ratio of one engineer per seven employees. Ongoing engineering, research, and development activities create new products and identify Lee as a company continually advancing the technology of miniature fluid control components.

Our engineering departments have extensive prototype shops and test laboratories. Rigorous in-house qualification test programs ensure our customers receive only fully proven products. State of the art equipment and software enable our engineers to predict performance and diagnose issues associated with fluid control components. Continuous investment in our people and technology allows Lee to offer the best products and technical support available.

## **MANUFACTURING**

The Lee Company has over 1,000,000 square feet of modern manufacturing and office space on three campuses located in Westbrook and Essex, Connecticut. Almost all of the manufacturing of Lee products including machining, molding, assembling and testing is performed in-house at these facilities. We are equipped with the latest production equipment as well as a sophisticated computerized production control system. Substantial inventories of standard parts ensure quick delivery.

## **QUALITY ASSURANCE**

Quality assurance at The Lee Company is a management commitment of the highest order. The Precision Hydraulics Quality Management System is based on AS9100, and the Electro-Fluidic Systems Quality Management System is based on ISO 9001. Both divisions comply with ISO10012-1. Our quality systems are supported by a documented lot control and traceability system which creates a framework for clearly defining the control of materials, processes, and verification activities, thus providing our customers with the confidence that the design and manufacture of our products are performed in a well-defined and controlled environment. The IMH group's quality system is certified to IATF 16949, the automotive industry quality standard.

These quality systems, which include extensive use of Statistical Process Control, have enabled The Lee Company to be awarded Certified Supplier status by many of our customers. This allows those companies to receive Lee products directly into stock saving the costs and delays associated with incoming inspection. Quality Assurance surveys, audits, and source inspections are always welcomed by Lee. The Lee Company is also willing to work to any special Q.A. specifications required by our customers.

## **QUALITY POLICY**

The Lee Company's Quality Policy ensures that we are able to comply with the requirements of AS9100. The commitment ensures continually improving the effectiveness of the Quality Management System, quality objectives, targets, and measurements of objectives. The mission of The Lee Company is to design and build state-of-the-art products that exceed customers' expectations for utility, performance, and quality. The Lee Company constantly strives to improve the product designs, the manufacturing process, and the quality system. The ultimate goal is zero defects and a satisfied customer.

## **PRODUCT DIVISIONS**

The Lee Company is organized into three separate divisions: Precision Hydraulics, Electro-Fluidic Systems (EFS), and Industrial Microhydraulics (IMH). Within each division there are one or more product groups, each with their own dedicated engineering, manufacturing, and sales team working together to provide innovative products and first class service. This structure allows us to be very responsive to our customers, offering solutions to solve difficult fluid control problems.

The six Precision Hydraulic product groups supply expansion plugs, high pressure solenoid valves, single and multi-orifice restrictors, nozzles, safety screens, check valves, relief valves, flow metering valves, shuttle valves and pumps to a wide range of industries. These include hydraulic and pneumatic applications on commercial and military aircraft, spacecraft, missiles, naval vessels, machine tools, downhole oil drilling and completion equipment, power generation equipment, high performance racing vehicles, etc.

The three Electro-Fluidic Systems (EFS) product groups produce high quality miniature solenoid valves (conventional and chemically inert models), high speed micro-dispense valves, atomizing and dispense nozzles, fixed and variable volume pumps, integrated fluidic manifolds, inert tubing and fluid control components, and custom engineered designs. These products

## VIII Introduction

are typically used in medical and scientific instrumentation, analytical and clinical chemistry, in vitro diagnostics, drug discovery and ink jet printing applications.

The Industrial Microhydraulics (IMH) Division was established to adapt proven design concepts to meet the higher volume production, performance, and cost requirements of automotive, industrial hydraulics, and medical applications. These products include a wide variety of plugs, valves, restrictors, and safety screens designed and manufactured for ease of automated installation, which is of paramount importance to these industries.

### **SALES AND SERVICE**

The Lee Company is committed to providing full professional service to our customers through a worldwide sales network of graduate engineers. Lee has sales offices near Los Angeles, San Francisco, Chicago, Tampa, Dallas, Houston, Detroit, and at the Technical Center in Westbrook. Lee also has wholly owned sales and service subsidiaries in London (Gerrards Cross), Frankfurt, Paris (Voisins-Le-Bretonneux), Milan and Stockholm, and is represented in over forty countries.

If you have a fluid control problem and would like to talk to an engineer, or would like product information, please contact us here at the Technical Center, or contact the field sales office (see listing on inside cover) nearest you.

## **SPECIAL PRODUCTS**

The Lee Company offers many miniature flow control components other than the standard products described in this handbook. In fact, approximately 50% of all Lee products are special or custom items designed to meet the requirements of a specific application. The majority of these special products are minor variations of standard products and may differ only slightly in: lohm rate, cracking pressure, leakage, flow testing, materials, etc. . . The remainder are uniquely different from the “standards” described in this handbook and include the following:

- air assisted atomizing nozzles
- gas turbine engine fuel nozzles
- transmission/gearbox lubrication nozzles
- eductors or “jet pumps”
- mechanically actuated and indicating valves
- absolute upstream pressure regulators (pneumatic)
- HI-BAR safety screens of almost any configuration
- valves optimized for pneumatic performance
- valves that operate in extreme temperature and pressure environments
- solenoid valves with customized electrical performance or connectors

The Lee Company sales and engineering staffs are eager to help you in solving your fluid control problems with special products that fill your needs. Please contact your local Lee Company sales office or the Technical Center in Westbrook, Connecticut for assistance.

X

# New Products Introduction

Pri™/Chek™  
Combination  
Valve  
H4-11



Flow Fuse  
H14-15



Dual Sealing  
A.F.O. Plug  
A60-63



375 Bypass  
Valve  
H12-13



250 H  
Bender Jet  
B64-67



5K Jeva™  
B74-77



156 High Pressure  
Bender Jet  
B60-61



QIP™ Plug  
A32-33



**Hi-Q PRV**  
F38-39



**687 PRV**  
F28-29



**High Pressure Pilot  
Operated Chek™**  
E82-87



**.500  
Zero  
Leak  
Chek™**  
E56-57



**.093  
Lee Chek®**  
E18-19



**Zero Leak  
Pri™**  
F16-17,  
44-45



**.375 Shuttle Valve**  
G24-25, 30-31



**High Pressure®  
250 Flosert**  
C30-31



**.250 Inverse  
Shuttle Valve**  
G42-43



**187 & 281 High Pressure  
Flow Controls**  
C16-19



Peek Hi-Bar®  
Screen  
I84-85



MP35N Hi-Bar®  
Screen  
I84-85



Brass Hi-Bar®  
Screen  
I84-85



Titanium Hi-Bar®  
Screen  
I84-85



Boss Mount  
Strainers  
I55-57



Catch-All™ Safety  
Screens  
I42-43

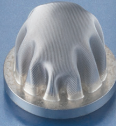



# XIV Introduction

**Lee Plugs****A****Lee Restrictors****B****Lee Flow Metering Valves****C****Lee Nozzles****D****Lee Chek Valves****E****Lee Relief Valves****F****Lee Shuttle Valves****G****Lee Combination & Shut-Off Valves****H****Lee Safety Screens****I****Lee Piloting Solenoid Valves****J****Lee Pumps****K****Lee Line Mounts****L****Pressure Components****M****Installation****N****Engineering****O**

# Lee Plugs

A





- ❑ Proof Pressures up to 32,000 psid
- ❑ Sizes from .093" to .656" in Diameter
- ❑ Aluminum, Stainless Steel or Monel Models Available
- ❑ High Pressure Plugs Available



(QUICK INSTALLATION PLUG)

- ❑ Simplified Installation
- ❑ Proof Pressures up to 12,000 psid
- ❑ Sizes from .093" to .187" in Diameter
- ❑ All Aluminum Construction



- ❑ No Downward Pressure During Installation
- ❑ No Support Shoulder Required
- ❑ Ideal For Thin Wall Applications
- ❑ Easily Removable



- ❑ Resuable – Allows Easy Access to Sealed Passageways
- ❑ Seals up to 56,000 psi
- ❑ Floating Seal Self Aligns – Prevents Galling
- ❑ Axial Force Only – Small Boss Size

## TABLE OF CONTENTS

<b>Introduction to Lee Plugs</b> .....	3 – 17
<b>Materials</b> .....	4
<b>Proof Pressure</b> .....	5
<b>Surface Treatment of Holes</b> .....	5
<b>Depth of Holes</b> .....	6
<b>Classes of Fit</b> .....	6
<b>Elongation</b> .....	7
<b>Boss Stress</b> .....	7
<b>Stress Corrosion</b> .....	14 – 15
<b>Quick Installation Plug</b> .....	16
<b>R.F.O.</b> .....	16
<b>A.F.O. / Dual Sealing A.F.O.</b> .....	17
<b>Lee Plugs</b>	
Aluminum .....	18 – 24
Stainless Steel .....	25 – 31
Quick Installation .....	16, 32 – 33
Monel .....	34 – 37
<b>Metric Lee Plugs</b>	
Aluminum .....	38 – 43
Stainless Steel .....	44 – 49
<b>Lee Plug R.F.O.</b> – Removable Plug, seals in thin walls without support shoulder .....	16, 50 – 55
<b>Lee Plug A.F.O.</b> – Removable, reusable plug, high pressure, high temperature applications .....	17, 56 – 57
<b>Lee Plug A.F.O.</b> – NACE Compliant .....	58 – 59
<b>Lee Plug Dual Sealing A.F.O.</b> – Plug with O-ring for venting trapped pressure or filling applications .....	17, 60 – 61
<b>Lee Plug Dual Sealing A.F.O.</b> <b>NACE Compliant</b> .....	62 – 63
<b>Lee High Strength Plug</b> For High Strength, High Hardness materials, and for High Pressures .....	64 – 67

## THE PRINCIPLE OF LEE PLUG PERFORMANCE

The Lee Plug is a cylindrical plug with a tapered hole part way through its center and numerous small grooves on its outside diameter. It is slipped into a reamed counterbore in the product. A tapered pin is then driven into the plug until the ends of the pin and the plug are flush with each other. Controlled expansion causes the lands and grooves of the plug to “bite” into the surrounding material forming independent seals and retaining rings. Result: a positive, reliable, leak and trouble-proof seal for both liquids and gases. **This simple principle opens the way to vast improvements in design and manufacture of all fluid devices.**

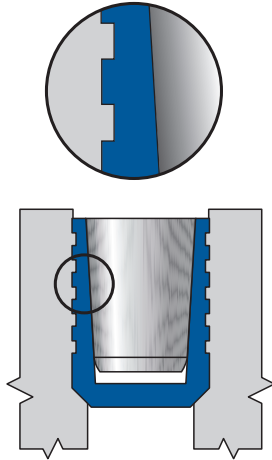

The Lee Plug is simply the most successful method to seal drilled holes for critical applications. Over 150 million are in use on aircraft, missiles, spacecraft, machine tools, down hole oil tools, molds – anything that requires a permanent leak-proof seal.

Lee Plugs are manufactured to exacting tolerances. Every process is precisely controlled. Critical dimensions are 100% checked and others are statistically checked. All plugs and pins are 100% visually inspected. In addition, every lot of Lee Pins and Plugs is production acceptance tested. A representative sample of the mating pin or plug are performance tested to a Lee Company process specification for installation, leakage, pin retention, proof pressure and thermal stability. Two certificates of performance (one for the pin lot and one for the plug lot) accompany every shipment of Lee Plugs.

Lee Plug expansion plugs are available in four different versions; the original Lee Plug, the QIP Plug, the R.F.O. Plug, and the High Strength Plug. The Lee Plug is stocked in five materials in English sizes (2024-T4 or T351 Aluminum, 7075-T6 or T651 Aluminum, 416 CRES, 303 CRES, and R405 Monel in long sizes) and three materials (2024-T4 or T351 Aluminum, 416 CRES, and 303 CRES) in the metric sizes. In addition, Lee Plugs are available in 2024-T6 Al, 6061-T6 Al, 316 CRES and 6AL-4V Ti.

For sealing holes in thin walls or fragile materials the R.F.O. plug is available. Because the R.F.O. doesn't require a seating shoulder, holes in extra-thin walled canisters, tanks, piping or ducts can be sealed. The installation system assures that no downward pressure is applied to the product.

For high pressure systems, The Lee Company has developed the High Strength Plug. The design has been optimized for use in high strength/high hardness materials such as the precipitation hardenable steels and titanium commonly found in high pressure systems.

## **MATERIALS**

Lee Plugs and Pins are made from materials that fall within the overall limits of the specifications shown in this handbook. In fact, The Lee Company exclusively purchases mill runs of material controlled to closer physical and chemical limits per Lee Company specification.

We do not approve the use of material meeting only the 416 specification.

### PLUG PROOF PRESSURE

To assist designers in the proper selection of Lee Plugs, a “proof pressure” is given for up to three hole tolerances (Classes I, II, III). The Lee Plug proof pressure is the highest hydrostatic pressure that may be applied in the course of routine Production Acceptance testing.

The Lee Plug proof pressure values stated in this Handbook are defined for Lee Plugs when installed into boss materials identical to that of the Plug. When installing Lee Plugs into dissimilar materials, please contact The Lee Company for proof pressure recommendations.

Lee Plugs should be selected conservatively. This will provide an additional safety margin for chance situations where the installation process might fail to meet specification or where pressure transients or other factors are unexpectedly severe. As a general guideline, we recommend the Proof Pressure of the Lee Plug chosen exceed the Burst Pressure of the system. **Note: Aluminum Plugs not recommended for use above 275°F.**

### SURFACE TREATMENT OF INSTALLATION HOLES

Proof pressure data for Lee components is given for installation in bosses without any surface treatment having been applied.

Passivating stainless steel installation holes per MIL-S-5002 or ASTM A 967 has no effect on the performance of Lee components. For aluminum we recommend untreated installation holes, however anodized holes per MIL-A-8625 Type II are generally acceptable.

We do not approve the use of some proprietary surface treatments which include the deposition of solid lubricants such as Teflon®.

®Teflon is a registered trademark of E.I. DuPont de Nemours & Co., Inc.

## A

**THE DEPTH OF THE REAMED HOLE**

The “A” Dimension on the hole charts shows the depth of the reamed hole recommended for maximum holding power. When using the recommended “A” dimensions, the back end of the plug and pin will always be at least 0.010 inch below the surface of the material. If it is desired to improve the appearance of the assembly, and maximum holding power is not a major concern, then the depth of the reamed hole can be made to equal the “M” dimension plus 0.010 inch. In doing so, the finished installation will be flush with the material surface. However, this will cause a reduction in proof pressure of approximately 20% for short Lee Plugs and 15% for long Lee Plugs. This procedure is not recommended for High Strength Plugs.

**SELECTION OF THE PROPER CLASS OF FIT**

As a general rule, the lowest class of fit compatible with pressure requirements should always be used. This will result in the lowest possible installed cost of the Lee Plug, since the lower the class of fit, the wider the tolerance band on the hole. The looser tolerances obviously reduce machining time and the time required to inspect the reamed hole.

Note that the selection of the lowest class of fit does not ensure the lightest interference fit in the reamed hole. It merely means that the interference can be anywhere from light to heavy. On the other hand, the highest class always ensures the heaviest interference fit. In cases where less interference is desirable, you should dimension your reamed hole using the maximum diameter from the lowest class and the maximum diameter from the next class up. In this way you will have a total tolerance of .001 inch and the lowest stresses in your material. Under these conditions the proof pressures would be the same as for the lowest class fits.

## ELONGATION

The expansion of a Lee Plug causes the boss material to be deformed, resulting in radial growth of the boss I.D. and O.D. In order to accommodate this growth, some consideration must be given to the ductility of the boss material. Generally, the boss material should have an elongation of at least 3%.

A typical Lee Plug installation will expand the boss I.D. by approximately 0.003 inch. Since this expansion remains relatively constant for all sizes of plugs, the smallest sizes are subject to the greatest percentage deformation. The worst case is a 0.093 inch diameter plug which will be expanded to 0.096 inch in a boss, or 3%. Thus, if the boss material has an elongation of over 3%, the boss will not crack from installation of the Lee Plug.

## BOSS STRESS

**Note: In many cases the factor limiting the boss diameter will be the proof pressure requirement and not the stresses.**

The success of the Lee Plug is founded upon its ability to provide high proof pressures with low, external boss stresses. If a typical installation is considered to be the equivalent of a 0.003 inch interference fit, then the hoop stresses ( $S_T$ ) can be expressed as a function of the Plug diameter ( $d$ ), boss diameter ( $D$ ), and yield point stress in tension ( $S_Y$ ) of the boss material. The Lee Plug lands and the boss material plastically deform, and in conjunction with the grooves, interlock to form many seals. This interlocking creates discontinuous bands of stress which quickly average out to a uniform stress at a diameter within the boss of  $1.2d$  or more.

The boss stresses, both tangential tensile ( $S_T$ ) and the radial compressive ( $S_R$ ) vary throughout the boss. At the interface between the plug lands and the boss (Pt.#1)  $S_{R1}$  is high and  $S_{T1}$  is low. At Pt.#2,  $S_{R2}$  is low and  $S_{T2}$  has reached its maximum. At Pt.#3, the only stresses are  $S_{T3}$  and the values are shown on the curve of  $S_{T3}$  on [page 9](#).

### Typical Lee Plug Installation

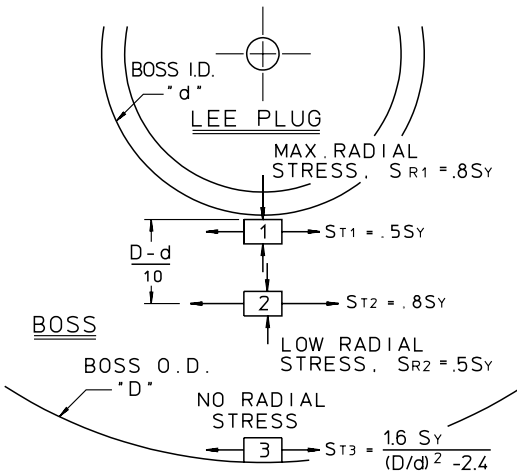

## The Effect of D/d on Proof Pressures and Stresses for Plug and Boss Materials with Similar Mechanical Properties

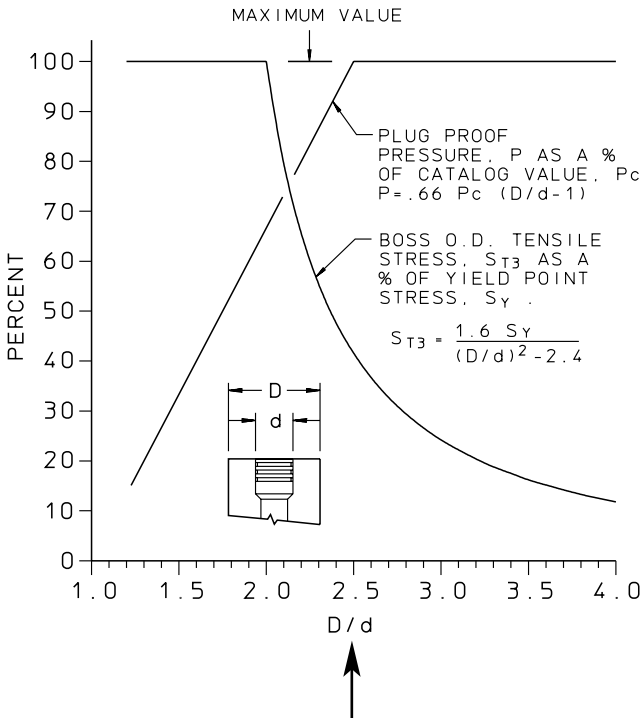

A D/d ratio of 2.5 is the minimum recommended by The Lee Company for cases in which the plug and boss are of similar materials.

**UNSYMMETRICAL BOSS STRESS**

For bosses that are not round the analysis is more complex, and thus a formula has been developed\* to aid in the solution of this difficult problem. The following formula allows a stress concentration factor, K, to be calculated as a function of certain boss geometric parameters. The formula is reasonably accurate, somewhat conservative, and applies to the stress in the plug boss at the minimum wall thickness area.

$$K = \frac{1}{B/360 [1 + A (360-B) / B]}$$

$$A = \frac{1}{1.65 (r-0.97)^{1/7}} \quad , r = \text{Boss wall thickness ratio (T/ t)}$$

$$B = a_t [1 + 0.3 \sin (a_t/2)] \quad , a_t = \text{angle of thin wall sector (deg.)}$$

**T/ t Ratio:** This is the ratio of the maximum boss wall thickness, to the minimum wall thickness. It is an indication of the nonsymmetry of the boss, and has a value of 1.0 for a round boss.

**Angle:** The angle is that sector of the boss which is at the minimum wall thickness. A round boss would have an angle of 360 degrees.

**D/d Ratio:** This is the ratio of the boss diameter at its minimum radius, to the plug outside diameter.

\*See Lee Technical Report No. 08-91-181 (Analytical Study to Evaluate Stresses in Unsymmetrical Lee Plug bosses).

See Figure I for examples of how the geometric parameters apply to real Lee plug bosses and Figure II, (pg. 12) for a plot of the formula results.

A typical problem is solved by using the round boss solution method with the  $D/d$  ratio as described above. The calculated stress is then multiplied by a stress concentration factor as determined from the formula.

### TYPICAL UNSYMMETRICAL BOSSES

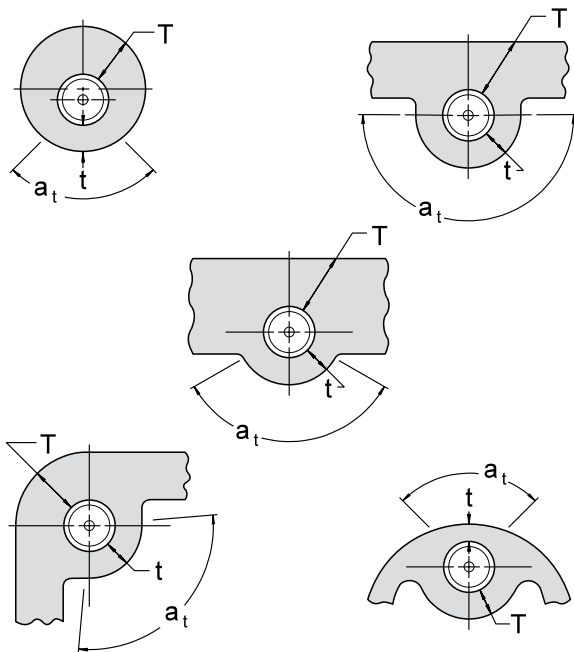

Figure I

These figures illustrate the applicability of the geometric parameters to variously shaped Lee Plug bosses.

NOTE: Although “ $t$ ” is always the boss minimum wall thickness, “ $T$ ” should be selected to be representative of the thick wall of the boss.

**STRESS CONCENTRATION FACTOR**  
vs. boss angle and thickness ratio

Figure II

**BOSS STRESS – DISSIMILAR MATERIALS**

When a Lee Plug is installed in a boss material of dissimilar mechanical properties, its proof pressure will be best maintained by observing the D/d ratios shown on the graph below. The stress at the O.D. of the boss will be below 40% of the tensile yield strength of the boss material when using these curves. This is a stress level that has been determined to be satisfactory in most applications.

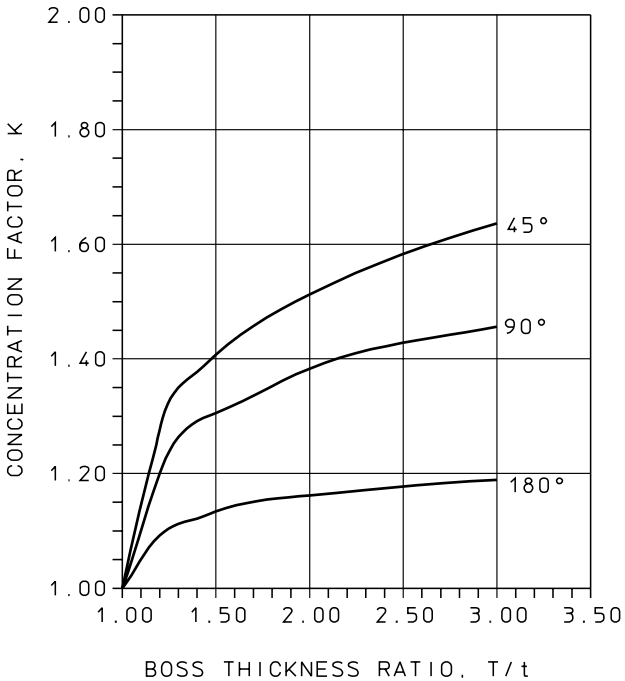
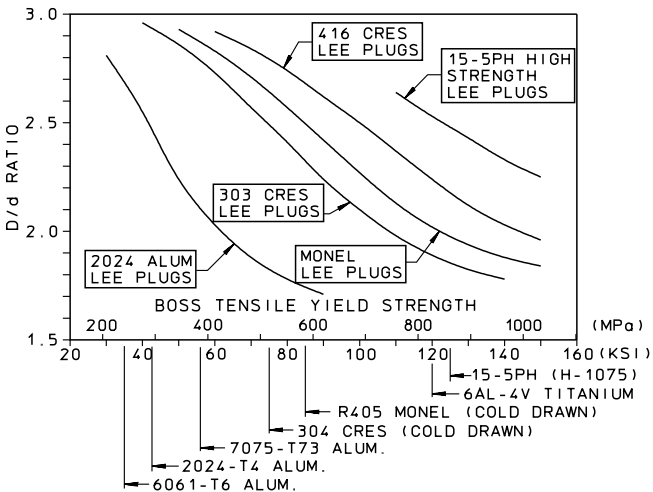

Example: A 303 CRES Plug is being designed into a 15-5 PH CRES housing. As can be seen from the graph, a D/d ratio of 1.9 is recommended to assure the rated proof pressure of the plug. In designing the boss with a D/d ratio of 1.9, the designer achieves a weight savings of 42% relative to a boss designed with a D/d ratio of 2.5.

### **BOSS STRESS – DISSIMILAR MATERIALS, continued**

When a Lee Plug is installed in a weaker boss material the holding strength of the plug will be limited by the strength of the boss material. Though the rated proof pressure will most likely be maintained, the choice of a significantly weaker boss could lessen the rated proof. The Lee Company should be contacted for technical assistance if there are questions about the plug/boss strength compatibility.

When a Lee Plug is installed in a stronger boss material the surface finish of the installation hole increases in importance. If the plug is significantly weaker than the boss material, retention relies more heavily on the friction at the plug/boss interface than on the plug grooves. Though the rated proof pressure will most likely be maintained, a surface finish smoother than the recommended limit may reduce the proof pressure of the plug.

### **STRESS CORROSION**

When certain materials are subjected to the combined effects of sustained tensile stress and corrosive environment, over a period of time, structural failure may occur at a stress lower than the material would normally withstand. This phenomenon is known as stress corrosion cracking, and it may occur in an environment which is not severely corrosive in the normal sense. To avoid failure, tensile stresses must not exceed a threshold value which is a function of the material and the application.

The boss in which a Lee Plug is installed will generally not be susceptible to stress corrosion cracking if a highly resistant boss material is used, and the D/d ratio is 2.5 or greater. The Lee Plug is not subject to stress corrosion since it is in compression throughout. Other values of D/d may be required if the mechanical properties of the boss differ significantly from those of the plug.

### Materials Highly Resistant\* to Stress Corrosion Cracking

ALLOY	CONDITION	YIELD STRESS (MIN.)	% ELONG. (MIN.)
2024 Alum	T851	58 ksi	5
6061 Alum (a)	T6	35 ksi	10
7075 Alum	T73	56 ksi	8
355, 356 Cast Alum	T6	17 ksi	3
15-5PH Cres (b)	H1075	125 ksi	13
300 Series Cres (a)	Cold Drawn	75 ksi typ.	35 typ.
4130 Cast Steel	Quenched & Tempered	85 ksi	16
6Al-4V Titanium (a)	Annealed	120 ksi	10
Monel Alloys (a)	Cold Drawn	85 ksi typ.	20 typ
Inconel Alloy 600	Annealed	35 ksi	30

- (a) All conditions are highly resistant to SCC.  
 (b) Condition H1000 and above is highly resistant to SCC.

\* The following alloys have low resistance to SCC, and are generally not recommended for Lee plug bosses (partial list):  
 Alum: 2024-T3 & T4, 7075-T6, Cres: 440c (all cond.)

### QUICK INSTALLATION PLUGS

The Lee Quick Installation Plugs combine ease of handling and installation with the proven reliability and performance of Lee Plug® expansion plugs. A leak-tight seal is created from Lee's controlled expansion principal. Quick Installation Plugs are offered in four sizes: .093, .125, .156, and .187 inches in diameter. Construction is all aluminum.

### R.F.O. PLUGS

R.F.O. Plugs (Radial Force Only) have the capability of sealing openings in thin shells as well as fragile materials. It is designed to fit into the passage without the use of a support shoulder, which eliminates downward pressure during installation. The R.F.O. Plug is installed using The Lee Company Hydraulic Installation Tool CUTX0100000B and removed with the appropriate bolt and striker. For installation/extraction procedure see [pages N17 – N20](#). For tool set part numbers see [page N20](#).

**A.F.O. PLUGS**

Lee A.F.O. Plugs (Axial Force Only) provide a leak-tight, metal to metal seal in high pressure/high temperature manifold applications. Designed to be both removable and reusable, the plug features a unique floating seal that self-aligns to allow for threaded holes that are not concentric with the thru-hole. Also, the seal does not rotate during installation, preventing galling of the seat. With only axial force being applied to the housing by design, small boss sizes can be utilized.

To meet the special demands of the oil and gas industries, NACE compliant A.F.O. Plugs are also available. These plugs conform to NACE MR0175 and offer exceptional corrosion resistance.

**DUAL SEALING A.F.O. PLUGS**

The Lee Dual Sealing A.F.O. (axial force only) Plugs provide a leak-tight, metal to metal seal in high pressure applications and also incorporates an O-ring for venting. Pressure can be vented out of a side port to remove air from a hydraulic system or safely release trapped high pressure gas.

A

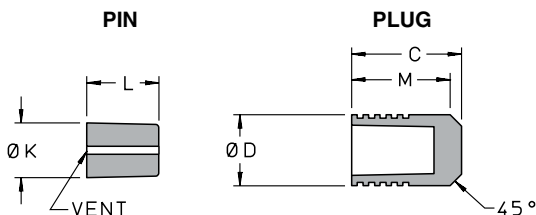

LEE PART NUMBER	093		125	
	SHORT PLGA 0930010A	LONG PLGA 0931010A	SHORT PLGA 1250010A	LONG PLGA 1251010A
D Max.	.0937	.0937	.1250	.1250
D Min.	.0928	.0928	.1241	.1241
C Nom.	.098	.143	.128	.193
M Nom.	.078	.123	.108	.173
K Nom.	.069	.069	.095	.095
L Nom.	.062	.095	.086	.125
Weight (gr.)	.03	.04	.06	.10
	<b>PROOF PRESSURE (psi x 1000)</b>			
CLASS 1	6	10	6	10
CLASS 2	8	13	8	13
CLASS 3	10	16	10	16
	<b>REAM DIAMETERS</b>			
CLASS 1	.0937 – .0962		.1250 – .1275	
CLASS 2	.0937 – .0952		.1250 – .1265	
CLASS 3	.0937 – .0942		.1250 – .1255	
A Min.	.097	.145	.125	.195
N Dia. Ref.	.062	.062	.093	.093
W Min.	.125	.125	.125	.125

**MATERIALS**

PIN &amp; PLUG: 2024-T4 or T351 aluminum per SAE AMS-QQ-A-225/6

**FINISH**

PIN: Alodine Yellow per MIL-DTL-5541 &amp; Wax

PLUG: Anodize Green per MIL-A-8625 Type II B

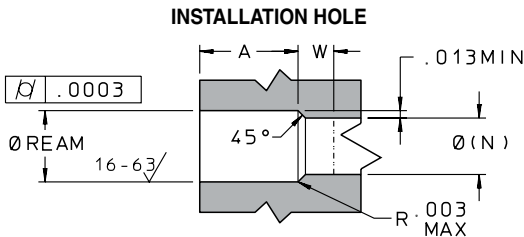

LEE PART NUMBER	156		187	
	SHORT PLGA 1560010A	LONG PLGA 1561010A	SHORT PLGA 1870010A	LONG PLGA 1871010A
D Max.	.1562	.1562	.1875	.1875
D Min.	.1553	.1553	.1866	.1866
C Nom.	.125	.245	.160	.260
M Nom.	.110	.215	.135	.235
K Nom.	.118	.123	.154	.154
L Nom.	.078	.165	.114	.181
Weight (gr.)	.10	.20	.19	.31
	<b>PROOF PRESSURE (psi x 1000)</b>			
CLASS 1	8	10	8	10
CLASS 2	9	13	9	13
CLASS 3	12	16	10	15
	<b>REAM DIAMETERS</b>			
CLASS 1	.1562 – .1587		.1875 – .1900	
CLASS 2	.1562 – .1577		.1875 – .1890	
CLASS 3	.1562 – .1567		.1875 – .1880	
A Min.	.130	.250	.152	.253
N Dia. Ref.	.125	.125	.156	.156
W Min.	.125	.125	.125	.125

<b>MATERIALS</b>
PIN & PLUG: 2024-T4 or T351 aluminum per SAE AMS-QQ-A-225/6
<b>FINISH</b>
PIN: Alodine Yellow per MIL-DTL-5541 & Wax
PLUG: Anodize Green per MIL-A-8625 Type II B

For installation/extraction procedure see [page N4 – N9](#). For tool set & oversize part numbers see [page N10](#).

A

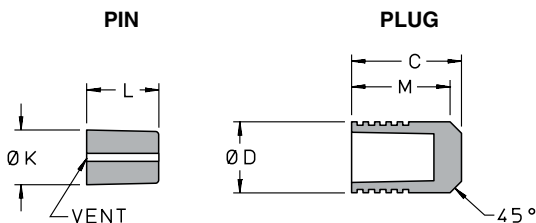

LEE PART NUMBER	218		250	
	SHORT PLGA 2180010A	LONG PLGA 2181010A	SHORT PLGA 2500010A	LONG PLGA 2501010A
D Max.	.2187	.2187	.2500	.2500
D Min.	.2178	.2178	.2491	.2491
C Nom.	.187	.307	.225	.365
M Nom.	.167	.277	.193	.333
K Nom.	.179	.182	.212	.212
L Nom.	.145	.218	.160	.265
Weight (gr.)	.30	.51	.46	.80
	<b>PROOF PRESSURE (psi x 1000)</b>			
CLASS 1	8	9	8	9
CLASS 2	9	12	9	12
CLASS 3	10	15	10	14
	<b>REAM DIAMETERS</b>			
CLASS 1	.2187 – .2212		.2500 – .2525	
CLASS 2	.2187 – .2202		.2500 – .2515	
CLASS 3	.2187 – .2192		.2500 – .2505	
A Min.	.187	.312	.212	.352
N Dia. Ref.	.187	.187	.218	.218
W Min.	.125	.125	.125	.125

**MATERIALS**

PIN &amp; PLUG: 2024-T4 or T351 aluminum per SAE AMS-QQ-A-225/6

**FINISH**

PIN: Alodine Yellow per MIL-DTL-5541 &amp; Wax

PLUG: Anodize Green per MIL-A-8625 Type II B

## INSTALLATION HOLE

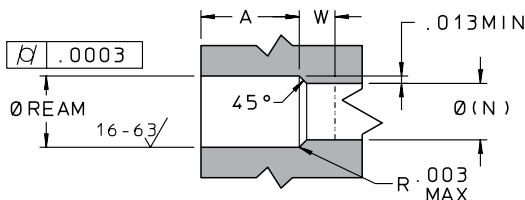

LEE PART NUMBER	281		312	
	SHORT PLGA 2810010A	LONG PLGA 2811010A	SHORT PLGA 3120010A	LONG PLGA 3121010A
D Max.	.2812	.2812	.3124	.3124
D Min.	.2803	.2803	.3115	.3115
C Nom.	.255	.370	.282	.436
M Nom.	.230	.340	.252	.406
K Nom.	.245	.247	.268	.270
L Nom.	.193	.280	.204	.308
Weight (gr.)	.69	1.0	.91	1.4
<b>PROOF PRESSURE (psi x 1000)</b>				
CLASS 1	8	9	8	9
CLASS 2	9	12	9	12
CLASS 3	10	14	10	14
<b>REAM DIAMETERS</b>				
CLASS 1	.2812 – .2837		.3124 – .3149	
CLASS 2	.2812 – .2827		.3124 – .3139	
CLASS 3	.2812 – .2817		.3124 – .3129	
A Min.	.250	.375	.269	.423
N Dia. Ref.	.250	.250	.281	.281
W Min.	.125	.125	.125	.125

## MATERIALS

PIN & PLUG: 2024-T4 or T351 aluminum per SAE AMS-QQ-A-225/6

## FINISH

PIN: Alodine Yellow per MIL-DTL-5541 & Wax

PLUG: Anodize Green per MIL-A-8625 Type II B

A

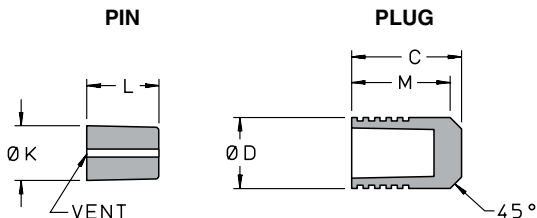

LEE PART NUMBER	343		406	
	SHORT PLGA 3430010A	LONG PLGA 3431010A	SHORT PLGA 4060010A	LONG PLGA 4061010A
D Max.	.3437	.3437	.4062	.4062
D Min.	.3428	.3428	.4053	.4053
C Nom.	.307	.500	.365	.565
M Nom.	.272	.410	.305	.465
K Nom.	.290	.294	.357	.357
L Nom.	.216	.335	.256	.397
Weight (gr.)	1.2	2.0	2.0	3.0
	<b>PROOF PRESSURE (psi x 1000)</b>			
CLASS 1	6	8	6	8
CLASS 2	8	11	8	10
CLASS 3	10	14	10	13
	<b>REAM DIAMETERS</b>			
CLASS 1	.3437 – .3462		.4062 – .4087	
CLASS 2	.3437 – .3452		.4062 – .4077	
CLASS 3	.3437 – .3442		.4062 – .4067	
A Min.	.295	.437	.325	.500
N Dia. Ref.	.312	.312	.375	.375
W Min.	.125	.125	.125	.125

**MATERIALS**

PIN &amp; PLUG: 2024-T4 or T351 aluminum per SAE AMS-QQ-A-225/6

**FINISH**

PIN: Alodine Yellow per MIL-DTL-5541 &amp; Wax

PLUG: Anodize Green per MIL-A-8625 Type II B

## INSTALLATION HOLE

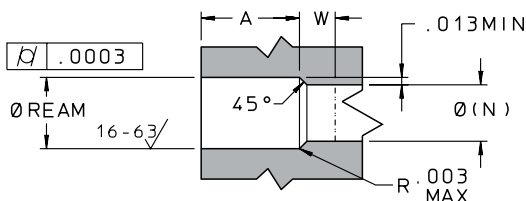

LEE PART NUMBER	468		531	
	SHORT PLGA 4680010A	LONG PLGA 4681010A	SHORT PLGA 5310010A	LONG PLGA 5311010A
D Max.	.4687	.4687	.5312	.5312
D Min.	.4678	.4678	.5303	.5303
C Nom.	.390	.620	.520	.680
M Nom.	.330	.530	.460	.590
K Nom.	.427	.419	.486	.482
L Nom.	.285	.460	.375	.522
Weight (gr.)	2.9	4.5	4.9	6.3
<b>PROOF PRESSURE (psi x 1000)</b>				
CLASS 1	6	7	6	6
CLASS 2	8	10	8	8
CLASS 3	10	12	10	12
<b>REAM DIAMETERS</b>				
CLASS 1	.4687 – .4712		.5312 – .5337	
CLASS 2	.4687 – .4702		.5312 – .5327	
CLASS 3	.4687 – .4692		.5312 – .5317	
A Min.	.350	.562	.486	.625
N Dia. Ref.	.437	.437	.500	.500
W Min.	.125	.125	.125	.125

## MATERIALS

PIN & PLUG: 2024-T4 or T351 aluminum per SAE AMS-QQ-A-225/6

## FINISH

PIN: Alodine Yellow per MIL-DTL-5541 & Wax

PLUG: Anodize Green per MIL-A-8625 Type II B

A

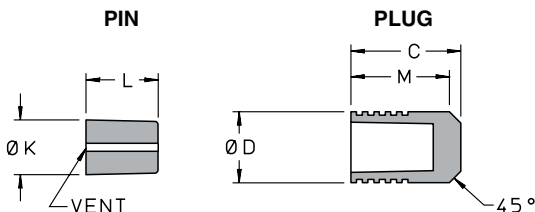

LEE PART NUMBER	656			
	SHORT PLGA 6560010A	LONG PLGA 6561010A		
D Max.	.6562	.6562		
D Min.	.6553	.6553		
C Nom.	.550	.750		
M Nom.	.470	.660		
K Nom.	.598	.601		
L Nom.	.390	.590		
Weight (gr.)	7.8	11.0		
	<b>PROOF PRESSURE</b> (psi x 1000)			
CLASS 1	3	4		
CLASS 2	4	7		
CLASS 3	5	10		
	<b>REAM DIAMETERS</b>			
CLASS 1	.6562 – .6587			
CLASS 2	.6562 – .6577			
CLASS 3	.6562 – .6567			
A Min.	.490	.685		
N Dia. Ref.	.625	.625		
W Min.	.125	.125		

**MATERIALS**

PIN &amp; PLUG: 2024-T4 or T351 aluminum per SAE AMS-QQ-A-225/6

**FINISH**

PIN: Alodine Yellow per MIL-DTL-5541 &amp; Wax

PLUG: Anodize Green per MIL-A-8625 Type II B

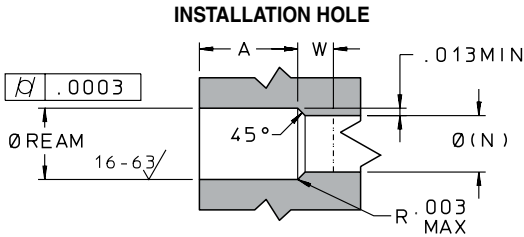

LEE PART NUMBER	093		125	
	SHORT PLGA 0930020A	LONG PLGA 0931020A	SHORT PLGA 1250020A	LONG PLGA 1251020A
D Max.	.0937	.0937	.1250	.1250
D Min.	.0928	.0928	.1241	.1241
C Nom.	.098	.143	.128	.193
M Nom.	.078	.123	.108	.173
K Nom.	.069	.069	.095	.095
L Nom.	.062	.095	.086	.125
Weight (gr.)	.07	.11	.17	.26
<b>PROOF PRESSURE (psi x 1000)</b>				
CLASS 1	10	18	14	18
CLASS 2	13	20	16	20
CLASS 3	15	24	20	24
<b>REAM DIAMETERS</b>				
CLASS 1	.0937 – .0962		.1250 – .1275	
CLASS 2	.0937 – .0952		.1250 – .1265	
CLASS 3	.0937 – .0942		.1250 – .1255	
A Min.	.097	.145	.125	.195
N Dia. Ref.	.062	.062	.093	.093
W Min.	.063	.063	.063	.063

<b>MATERIALS</b>
PIN & PLUG: 416 CRES Per QQ-S-763C, R <sub>c</sub> 20-34
<b>FINISH</b>
PIN: Passivated & Wax
PLUG: Passivated

A

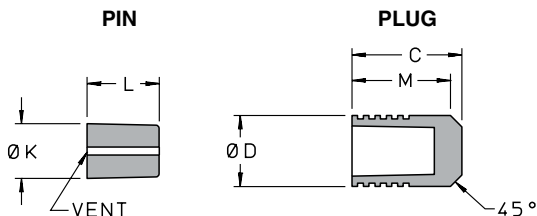

LEE PART NUMBER	156		187	
	SHORT PLGA 1560020A	LONG PLGA 1561020A	SHORT PLGA 1870020A	LONG PLGA 1871020A
D Max.	.1562	.1562	.1875	.1875
D Min.	.1553	.1553	.1866	.1866
C Nom.	.125	.245	.160	.260
M Nom.	.110	.215	.135	.235
K Nom.	.116	.118	.154	.154
L Nom.	.078	.175	.114	.181
Weight (gr.)	.28	.56	.51	.82
<b>PROOF PRESSURE (psi x 1000)</b>				
CLASS 1	8	18	12	18
CLASS 2	9	24	14	24
CLASS 3	10	28	16	28
<b>REAM DIAMETERS</b>				
CLASS 1	.1562 – .1587		.1875 – .1900	
CLASS 2	.1562 – .1577		.1875 – .1890	
CLASS 3	.1562 – .1567		.1875 – .1880	
A Min.	.130	.250	.152	.253
N Dia. Ref.	.125	.125	.156	.156
W Min.	.063	.063	.063	.063

**MATERIALS**PIN & PLUG: 416 CRES Per QQ-S-763C, R<sub>c</sub> 20-34**FINISH**

PIN: Passivated &amp; Wax

PLUG: Passivated

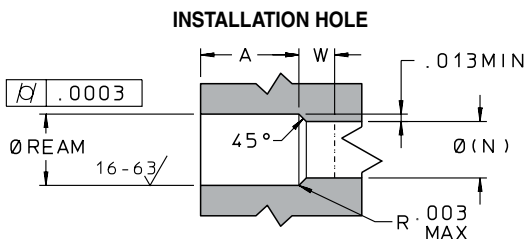

LEE PART NUMBER	218		250	
	SHORT PLGA 2180020A	LONG PLGA 2181020A	SHORT PLGA 2500020A	LONG PLGA 2501020A
D Max.	.2187	.2187	.2500	.2500
D Min.	.2178	.2178	.2491	.2491
C Nom.	.187	.307	.225	.365
M Nom.	.167	.277	.193	.333
K Nom.	.179	.181	.212	.212
L Nom.	.145	.218	.160	.265
Weight (gr.)	.83	1.4	1.3	2.2
<b>PROOF PRESSURE (psi x 1000)</b>				
CLASS 1	10	16	12	16
CLASS 2	12	22	14	22
CLASS 3	14	26	16	25
<b>REAM DIAMETERS</b>				
CLASS 1	.2187 – .2212		.2500 – .2525	
CLASS 2	.2187 – .2202		.2500 – .2515	
CLASS 3	.2187 – .2192		.2500 – .2505	
A Min.	.187	.312	.212	.352
N Dia. Ref.	.187	.187	.218	.218
W Min.	.063	.063	.063	.063

<b>MATERIALS</b>
PIN & PLUG: 416 CRES Per QQ-S-763C, R <sub>c</sub> 20-34
<b>FINISH</b>
PIN: Passivated & Wax
PLUG: Passivated

A

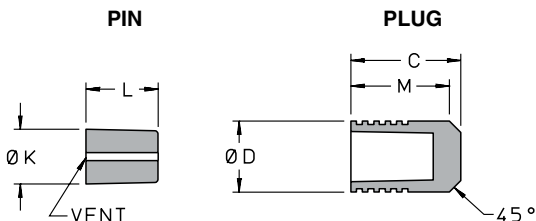

LEE PART NUMBER	281		312	
	SHORT PLGA 2810020A	LONG PLGA 2811020A	SHORT PLGA 3120020A	LONG PLGA 3121020A
D Max.	.2812	.2812	.3124	.3124
D Min.	.2803	.2803	.3115	.3115
C Nom.	.255	.370	.280	.436
M Nom.	.230	.340	.252	.406
K Nom.	.245	.244	.275	.276
L Nom.	.193	.280	.204	.308
Weight (gr.)	1.9	2.7	2.5	3.9
<b>PROOF PRESSURE (psi x 1000)</b>				
CLASS 1	12	18	12	18
CLASS 2	14	20	14	20
CLASS 3	16	24	16	24
<b>REAM DIAMETERS</b>				
CLASS 1	.2812 – .2837		.3124 – .3149	
CLASS 2	.2812 – .2827		.3124 – .3139	
CLASS 3	.2812 – .2817		.3124 – .3129	
A Min.	.250	.375	.269	.423
N Dia. Ref.	.250	.250	.281	.281
W Min.	.063	.063	.063	.063

**MATERIALS**PIN & PLUG: 416 CRES Per QQ-S-763C, R<sub>c</sub> 20-34**FINISH**

PIN: Passivated &amp; Wax

PLUG: Passivated

## INSTALLATION HOLE

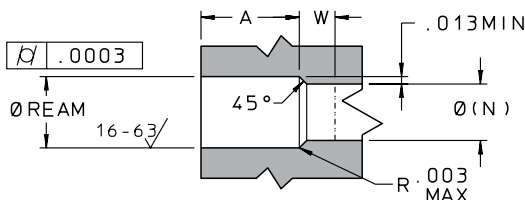

LEE PART NUMBER	343		406	
	SHORT PLGA 3430020A	LONG PLGA 3431020A	SHORT PLGA 4060020A	LONG PLGA 4061020A
D Max.	.3437	.3437	.4062	.4062
D Min.	.3428	.3428	.4053	.4053
C Nom.	.307	.500	.365	.565
M Nom.	.272	.410	.305	.465
K Nom.	.305	.308	.363	.370
L Nom.	.216	.335	.256	.397
Weight (gr.)	3.2	5.0	5.4	7.9
<b>PROOF PRESSURE (psi x 1000)</b>				
CLASS 1	10	18	10	16
CLASS 2	12	20	12	18
CLASS 3	14	22	14	21
<b>REAM DIAMETERS</b>				
CLASS 1	.3437 – .3462		.4062 – .4087	
CLASS 2	.3437 – .3452		.4062 – .4077	
CLASS 3	.3437 – .3442		.4062 – .4067	
A Min.	.295	.437	.325	.500
N Dia. Ref.	.312	.312	.375	.375
W Min.	.063	.063	.063	.063

## MATERIALS

PIN & PLUG: 416 CRES Per QQ-S-763C, R<sub>c</sub> 20-34

## FINISH

PIN: Passivated & Wax

PLUG: Passivated

A

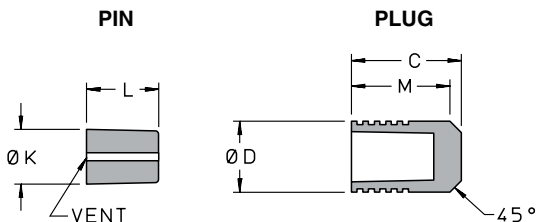

LEE PART NUMBER	468		531	
	SHORT PLGA 4680020A	LONG PLGA 4681020A	SHORT PLGA 5310020A	LONG PLGA 5311020A
D Max.	.4687	.4687	.5312	.5312
D Min.	.4678	.4678	.5303	.5303
C Nom.	.390	.620	.520	.680
M Nom.	.330	.530	.460	.590
K Nom.	.436	.433	.494	.495
L Nom.	.285	.460	.375	.522
Weight (gr.)	7.9	12.0	13.0	17.0
	<b>PROOF PRESSURE (psi x 1000)</b>			
CLASS 1	10	16	10	14
CLASS 2	12	18	12	16
CLASS 3	14	20	14	18
	<b>REAM DIAMETERS</b>			
CLASS 1	.4687 – .4712		.5312 – .5337	
CLASS 2	.4687 – .4702		.5312 – .5327	
CLASS 3	.4687 – .4692		.5312 – .5317	
A Min.	.350	.562	.486	.625
N Dia. Ref.	.437	.437	.500	.500
W. Min.	.063	.063	.063	.063

**MATERIALS**PIN & PLUG: 416 CRES Per QQ-S-763C, R<sub>c</sub> 20-34**FINISH**

PIN: Passivated &amp; Wax

PLUG: Passivated

## INSTALLATION HOLE

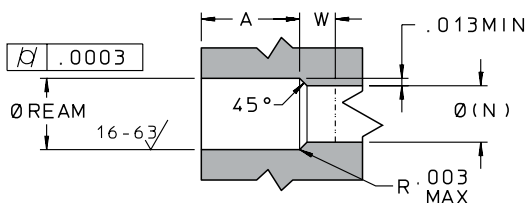

LEE PART NUMBER	656			
	SHORT PLGA 6560020A	LONG PLGA 6561020A		
D Max.	.6562	.6562		
D Min.	.6553	.6553		
C Nom.	.550	.750		
M Nom.	.470	.660		
K Nom.	.598	.601		
L Nom.	.390	.590		
Weight (gr.)	22.0	29.0		
	<b>PROOF PRESSURE</b> (psi x 1000)			
CLASS 1	6	10		
CLASS 2	8	14		
CLASS 3	10	16		
	<b>REAM DIAMETERS</b>			
CLASS 1	.6562 – .6587			
CLASS 2	.6562 – .6577			
CLASS 3	.6562 – .6567			
A Min.	.490	.685		
N Dia. Ref.	.625	.625		
W Min.	.063	.063		

## MATERIALS

PIN & PLUG: 416 CRES Per QQ-S-763C, R<sub>c</sub> 20-34

## FINISH

PIN: Passivated & Wax

PLUG: Passivated

A

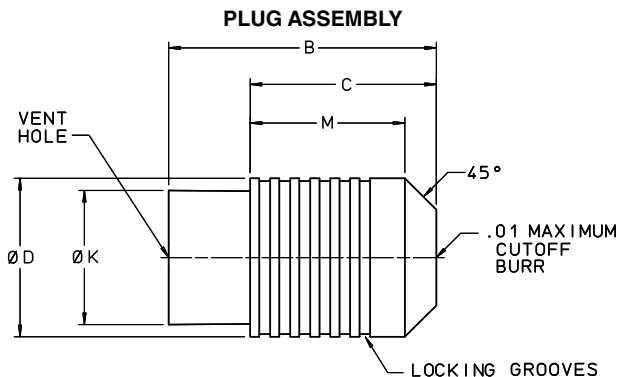

LEE PART NUMBER	093	125	156	187
	PLPA 0930010A	PLPA 1250010A	PLPA 1560010A	PLPA 1870010A
D Max.	0.0937	0.1250	0.1562	0.1875
D Min.	0.0928	0.1241	0.1553	0.1866
B Nom.	0.178	0.245	0.288	0.335
C Nom.	0.123	0.160	0.185	0.210
M Nom.	0.103	0.140	0.170	0.185
K Nom.	0.069	0.095	0.118	0.154
Weight (gr.)	0.025	0.066	0.150	0.200
<b>PROOF PRESSURE (psi x 1000)</b>				
CLASS 1	6	6	8	8
CLASS 2	8	8	9	9
CLASS 3	10	10	12	10
<b>REAM DIAMETERS</b>				
CLASS 1	.0937 – .0962	.1250 – .1275	.1562 – .1587	.1875 – .1900
CLASS 2	.0937 – .0952	.1250 – .1265	.1562 – .1577	.1875 – .1890
CLASS 3	.0937 – .0942	.1250 – .1255	.1562 – .1567	.1875 – .1880
A Min.	0.118	0.158	0.186	0.201
N Dia. Ref.	0.062	0.093	0.125	0.156
W Min.	0.125	0.125	0.125	0.125

For installation/extraction procedure see [page N6 – N9](#).

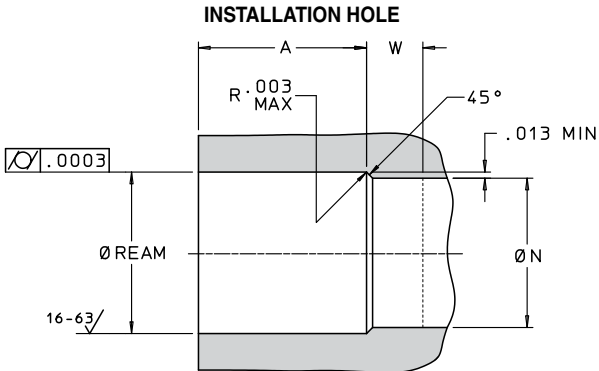

## MATERIALS

PIN & PLUG: 2024-T4 Aluminum per SAE AMS-QQ-A-225/6 and AMS 4120

## FINISH

PIN: Alodine Yellow per MIL-DTL-5541 & Wax

PLUG: Anodize Green per MIL-A-8625 Type IIB

A

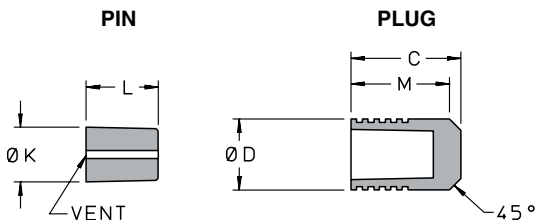

LEE PART NUMBER	093	125	156	187
	LONG PLGA 0931400A	LONG PLGA 1251400A	LONG PLGA 1561400A	LONG PLGA 1871400A
D Max.	.0937	.1250	.1562	.1875
D Min.	.0928	.1241	.1553	.1866
C Nom.	.143	.193	.245	.260
M Nom.	.123	.173	.215	.235
K Nom.	.069	.095	.118	.154
L Nom.	.095	.125	.175	.181
Weight (gr.)	.11	.26	.64	.95
<b>PROOF PRESSURE (psi x 1000)</b>				
CLASS 1	18	18	18	18
CLASS 2	20	20	24	24
CLASS 3	24	24	28	28
<b>REAM DIAMETERS</b>				
CLASS 1	.0937 - .0962	.1250 - .1275	.1562 - .1587	.1875 - .1900
CLASS 2	.0937 - .0952	.1250 - .1265	.1562 - .1577	.1875 - .1890
CLASS 3	.0937 - .0942	.1250 - .1255	.1562 - .1567	.1875 - .1880
A Min.	.145	.195	.250	.253
N Dia. Ref.	.062	.093	.125	.156
W Min.	.063	.063	.063	.063

**MATERIALS**

PIN &amp; PLUG: R405 Monel per QQ-N-281

**FINISH**

PIN: Wax

PLUG: None

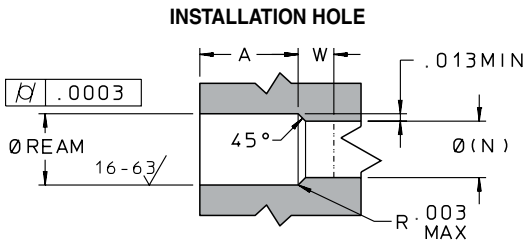

LEE PART NUMBER	218	250	281	312
	LONG PLGA 2181400A	LONG PLGA 2501400A	LONG PLGA 2811400A	LONG PLGA 3121400A
D Max.	.2187	.2500	.2812	.3124
D Min.	.2178	.2491	.2803	.3115
C Nom.	.307	.365	.370	.436
M Nom.	.277	.333	.340	.406
K Nom.	.181	.212	.244	.276
L Nom.	.218	.265	.280	.308
Weight (gr.)	1.6	2.6	3.1	4.5
<b>PROOF PRESSURE (psi x 1000)</b>				
CLASS 1	16	16	18	18
CLASS 2	22	22	20	20
CLASS 3	26	25	24	23
<b>REAM DIAMETERS</b>				
CLASS 1	.2187 - .2212	.2500 - .2525	.2812 - .2837	.3124 - .3149
CLASS 2	.2187 - .2202	.2500 - .2515	.2812 - .2827	.3124 - .3139
CLASS 3	.2187 - .2192	.2500 - .2505	.2812 - .2817	.3124 - .3129
A Min.	.312	.352	.375	.423
N Dia. Ref.	.187	.218	.250	.281
W Min.	.063	.063	.063	.063

<b>MATERIALS</b>
PIN & PLUG: R405 Monel per QQ-N-281
<b>FINISH</b>
PIN: Wax
PLUG: None

A

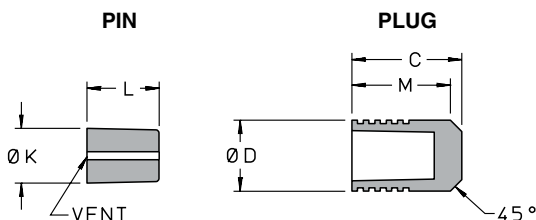

LEE PART NUMBER	343	406	468	
	LONG PLGA 3431400A	LONG PLGA 4061400A	LONG PLGA 4681400A	
D Max.	.3437	.4062	.4687	
D Min.	.3428	.4053	.4678	
C Nom.	.500	.565	.620	
M Nom.	.410	.465	.530	
K Nom.	.308	.370	.433	
L Nom.	.335	.397	.460	
Weight (gr.)	5.7	9.0	14.0	
<b>PROOF PRESSURE (psi x 1000)</b>				
CLASS 1	18	16	16	
CLASS 2	20	18	18	
CLASS 3	22	21	20	
<b>REAM DIAMETERS</b>				
CLASS 1	.3437 - .3462	.4062 - .4087	.4687 - .4712	
CLASS 2	.3437 - .3452	.4062 - .4077	.4687 - .4702	
CLASS 3	.3437 - .3442	.4062 - .4067	.4687 - .4692	
A Min.	.437	.500	.562	
N Dia. Ref.	.312	.375	.437	
W Min.	.063	.063	.063	

**MATERIALS**

PIN &amp; PLUG: R405 Monel per QQ-N-281

**FINISH**

PIN: Wax

PLUG: None

## INSTALLATION HOLE

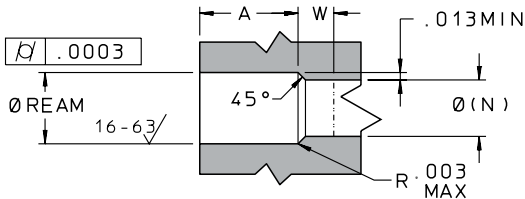

LEE PART NUMBER	531	656		
	LONG PLGA 5311400A	LONG PLGA 6561400A		
D Max.	.5312	.6562		
D Min.	.5303	.6553		
C Nom.	.680	.750		
M Nom.	.590	.660		
K Nom.	.495	.601		
L Nom.	.522	.590		
Weight (gr.)	20.0	34.0		
	<b>PROOF PRESSURE (psi x 1000)</b>			
CLASS 1	14	10		
CLASS 2	16	14		
CLASS 3	18	16		
	<b>REAM DIAMETERS</b>			
CLASS 1	.5312 - .5337	.6562 - .6587		
CLASS 2	.5312 - .5327	.6562 - .6577		
CLASS 3	.5312 - .5317	.6562 - .6567		
A Min.	.625	.685		
N Dia. Ref.	.500	.625		
W Min.	.063	.063		

## MATERIALS

PIN & PLUG: R405 Monel per QQ-N-281

## FINISH

PIN: Wax

PLUG: None

A

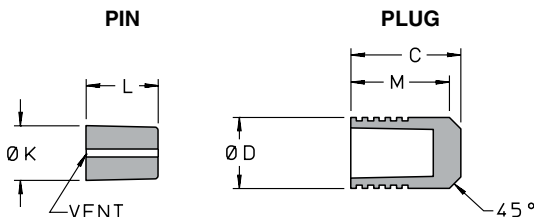

LEE PART NUMBER	2,50	3,00	3,50	
	SHORT PLGM 0250010A	SHORT PLGM 0300010A	SHORT PLGM 0350010A	
D Max.	2,50	3,00	3,50	
D Min.	2,48	2,98	3,48	
C Nom.	2,75	3,20	3,66	
M Nom.	2,24	2,65	3,00	
K Nom.	1,88	2,26	2,56	
L Nom.	1,89	2,27	2,66	
Weight (gr.)	0,04	0,06	0,09	
<b>PROOF PRESSURE (MPa)</b>				
CLASS 1	49	49	49	
CLASS 2	59	69	59	
CLASS 3	69	88	88	
<b>REAM DIAMETERS</b>				
CLASS 1	H11* 2,50-2,56	H10* 3,00-3,06	H10* 3,50-3,56	
CLASS 2	H9* 2,50-2,54	H9* 3,00-3,04	H9* 3,50-3,54	
CLASS 3	H7* 2,50-2,51	H7* 3,00-3,01	H7* 3,50-3,51	
A Min.	2,7	3,1	3,4	
N Dia. Ref.	1,7	2,2	2,7	
W Min.	3,2	3,2	3,2	

**MATERIALS**

PIN &amp; PLUG: 2024-T4 or T351 aluminum per SAE AMS-QQ-A-225/6

**FINISH**

PIN: Alodine Yellow per MIL-DTL-5541 &amp; Wax

PLUG: Anodize Brown per MIL-A-8625 Type II B

For installation/extraction procedure see page N4 – N9. For tool set part numbers see page N13.

\*DIN 7154 tolerances fall within ream tolerances.

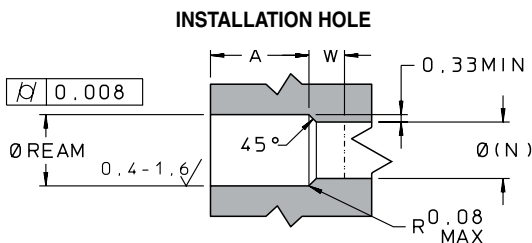

LEE PART NUMBER	4,00		4,50	
	SHORT PLGM 0400010A	LONG PLGM 0401010A	SHORT PLGM 0450010A	LONG PLGM 0451010A
D Max.	4,00	4,00	4,50	4,50
D Min.	3,98	3,98	4,48	4,48
C Nom.	4,09	6,63	4,55	7,19
M Nom.	3,40	6,10	3,81	6,61
K Nom.	3,08	3,07	3,58	3,57
L Nom.	2,96	5,48	3,29	6,03
Weight (gr.)	0,13	0,22	0,18	0,30
<b>PROOF PRESSURE (MPa)</b>				
CLASS 1	49	69	49	69
CLASS 2	59	88	59	88
CLASS 3	83	102	69	102
<b>REAM DIAMETERS</b>				
CLASS 1	H10*	4,00 - 4,06	H10*	4,50 - 4,56
CLASS 2	H9*	4,00 - 4,04	H9*	4,50 - 4,54
CLASS 3	H7*	4,00 - 4,01	H7*	4,50 - 4,51
A Min.	3,9	6,6	4,3	7,1
N Dia. Ref.	3,2	3,2	3,7	3,7
W Min.	3,2	3,2	3,2	3,2

## MATERIALS

PIN & PLUG: 2024-T4 or T351 aluminum per SAE AMS-QQ-A-225/6

## FINISH

PIN: Alodine Yellow per MIL-DTL-5541 & Wax

PLUG: Anodize Brown per MIL-A-8625 Type II B

For installation/extraction procedure see [page N4 – N9](#). For tool set part numbers see [page N13](#).

\*DIN 7154 tolerances fall within ream tolerances.

A

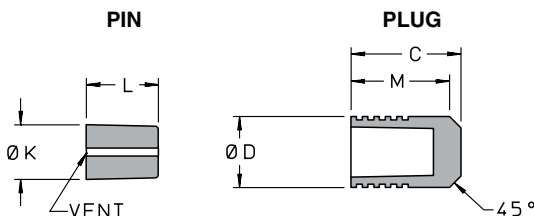

LEE PART NUMBER	5,00		5,50	
	SHORT PLGM 0500010A	LONG PLGM 0501010A	SHORT PLGM 0550010A	LONG PLGM 0551010A
D Max.	5,00	5,00	5,50	5,50
D Min.	4,98	4,98	5,48	5,48
C Nom.	4,98	7,75	5,36	8,31
M Nom.	4,22	7,12	4,60	7,62
K Nom.	4,08	4,07	4,59	4,57
L Nom.	3,72	6,47	4,08	6,87
Weight (gr.)	0,25	0,39	0,33	0,51
	<b>PROOF PRESSURE (MPa)</b>			
CLASS 1	49	69	49	64
CLASS 2	59	88	59	83
CLASS 3	69	102	69	102
	<b>REAM DIAMETERS</b>			
CLASS 1	H10*	5,00 - 5,06	H10*	5,50 - 5,56
CLASS 2	H9*	5,00 - 5,04	H9*	5,50 - 5,54
CLASS 3	H7*	5,00 - 5,01	H7*	5,50 - 5,51
A Min.	4,7	7,6	5,1	8,1
N Dia. Ref.	4,2	4,2	4,7	4,7
W Min.	3,2	3,2	3,2	3,2

**MATERIALS**

PIN &amp; PLUG: 2024-T4 or T351 aluminum per SAE AMS-QQ-A-225/6

**FINISH**

PIN: Alodine Yellow per MIL-DTL-5541 &amp; Wax

PLUG: Anodize Brown per MIL-A-8625 Type II B

For installation/extraction procedure see [page N4 – N9](#). For tool set part numbers see [page N13](#).

\*DIN 7154 tolerances fall within ream tolerances.

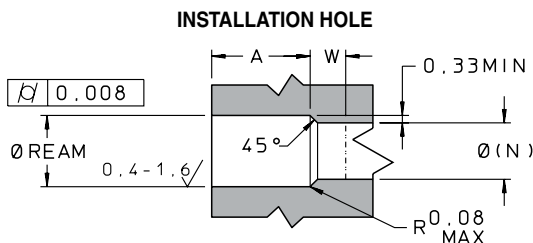

LEE PART NUMBER	6,00		6,50	
	SHORT PLGM 0600010A	LONG PLGM 0601010A	SHORT PLGM 0650010A	LONG PLGM 0651010A
D Max.	6,00	6,00	6,50	6,50
D Min.	5,98	5,98	6,48	6,48
C Nom.	5,77	8,84	6,30	9,40
M Nom.	5,01	8,11	5,52	8,62
K Nom.	5,08	5,07	5,59	5,57
L Nom.	4,28	7,24	4,69	7,49
Weight (gr.)	0,43	0,64	0,53	0,81
	<b>PROOF PRESSURE (MPa)</b>			
CLASS 1	49	64	49	64
CLASS 2	59	83	59	83
CLASS 3	69	98	69	98
	<b>REAM DIAMETERS</b>			
CLASS 1	H10*	6,00 - 6,06	H10*	6,50 - 6,56
CLASS 2	H9*	6,00 - 6,04	H9*	6,50 - 6,54
CLASS 3	H6*	6,00 - 6,01	H6*	6,50 - 6,51
A Min.	5,5	8,6	6,0	9,1
N Dia. Ref.	5,2	5,2	5,7	5,7
W Min.	3,2	3,2	3,2	3,2

## MATERIALS

PIN & PLUG: 2024-T4 or T351 aluminum per SAE AMS-QQ-A-225/6

## FINISH

PIN: Alodine Yellow per MIL-DTL-5541 & Wax

PLUG: Anodize Brown per MIL-A-8625 Type II B

For installation/extraction procedure see [page N4 – N9](#). For tool set part numbers see [page N14](#).

\*DIN 7154 tolerances fall within ream tolerances.

A

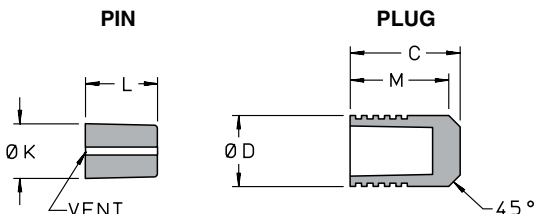

LEE PART NUMBER	7,00		7,50	
	SHORT PLGM 0700010A	LONG PLGM 0701010A	SHORT PLGM 0750010A	LONG PLGM 0751010A
D Max.	7,00	7,00	7,50	7,50
D Min.	6,98	6,98	7,48	7,48
C Nom.	6,73	9,93	7,19	10,49
M Nom.	5,92	9,12	6,30	9,61
K Nom.	6,06	6,06	6,53	6,53
L Nom.	5,04	8,13	5,39	8,51
Weight (gr.)	0,66	1,0	0,81	1,2
<b>PROOF PRESSURE (MPa)</b>				
CLASS 1	49	64	39	64
CLASS 2	59	83	54	83
CLASS 3	69	98	69	98
<b>REAM DIAMETERS</b>				
CLASS 1	H10*	7,00 - 7,06	H10*	7,50 - 7,56
CLASS 2	H9*	7,00 - 7,04	H9*	7,50 - 7,54
CLASS 3	H6*	7,00 - 7,01	H6*	7,50 - 7,51
A Min.	6,4	9,6	6,8	10,1
N Dia. Ref.	6,2	6,2	6,7	6,7
W Min.	3,2	3,2	3,2	3,2

**MATERIALS**

PIN &amp; PLUG: 2024-T4 or T351 aluminum per SAE AMS-QQ-A-225/6

**FINISH**

PIN: Alodine Yellow per MIL-DTL-5541 &amp; Wax

PLUG: Anodize Brown per MIL-A-8625 Type II B

For installation/extraction procedure see [page N4 - N9](#). For tool set part numbers see [page N14](#).  
 \*DIN 7154 tolerances fall within ream tolerances.

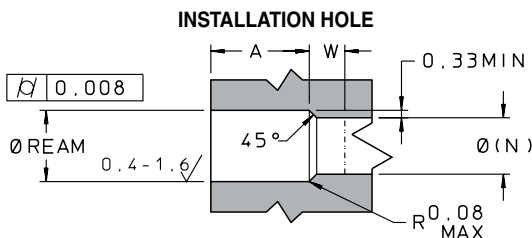

LEE PART NUMBER	8,00			
	SHORT PLGM 0800010A	LONG PLGM 0801010A		
D Max.	8,00	8,00		
D Min.	7,98	7,98		
C Nom.	7,62	11,05		
M Nom.	6,74	10,11		
K Nom.	7,05	7,05		
L Nom.	5,69	9,02		
Weight (gr.)	0,99	1,5		
<b>PROOF PRESSURE (MPa)</b>				
CLASS 1	39	59		
CLASS 2	54	79		
CLASS 3	69	98		
<b>REAM DIAMETERS</b>				
CLASS 1	H10*	8,00 - 8,06		
CLASS 2	H9*	8,00 - 8,04		
CLASS 3	H6*	8,00 - 8,01		
A Min.	7,2	10,6		
N Dia. Ref.	7,2	7,2		
W Min.	3,2	3,2		

<b>MATERIALS</b>
PIN & PLUG: 2024-T4 or T351 aluminum per SAE AMS-QQ-A-225/6
<b>FINISH</b>
PIN: Alodine Yellow per MIL-DTL-5541 & Wax
PLUG: Anodize Brown per MIL-A-8625 Type II B

For installation/extraction procedure see [page N4 – N9](#). For tool set part numbers see [page N14](#). \*DIN 7154 tolerances fall within ream tolerances.

A

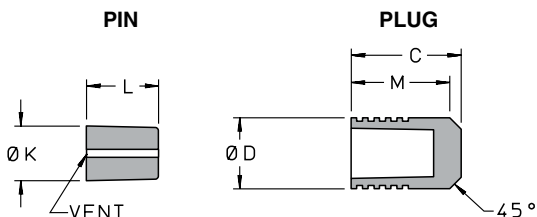

LEE PART NUMBER	2,50	3,00	3,50	
	SHORT PLGM 0250020A	SHORT PLGM 0300020A	SHORT PLGM 0350020A	
D Max.	2,50	3,00	3,50	
D Min.	2,48	2,98	3,48	
C Nom.	2,75	3,20	3,66	
M Nom.	2,24	2,65	3,00	
K Nom.	1,86	2,24	2,64	
L Nom.	1,89	2,27	2,66	
Weight (gr.)	0,11	0,16	0,24	
	<b>PROOF PRESSURE (MPa)</b>			
CLASS 1	98	98	98	
CLASS 2	113	113	113	
CLASS 3	137	137	137	
	<b>REAM DIAMETERS</b>			
CLASS 1	H11* 2,50-2,56	H10* 3,00-3,06	H10* 3,50-3,56	
CLASS 2	H9* 2,50-2,54	H9* 3,00-3,04	H9* 3,50-3,54	
CLASS 3	H7* 2,50-2,51	H7* 3,00-3,01	H7* 3,50-3,51	
A Min.	2,7	3,1	3,4	
N Dia. Ref.	1,7	2,2	2,7	
W Min.	1,6	1,6	1,6	

**MATERIALS**PIN & PLUG: 416 CRES Per QQ-S-763C, R<sub>c</sub> 20-34**FINISH**

PIN: Passivated &amp; Wax

PLUG: Passivated

For installation/extraction procedure see [page N4 – N9](#). For tool set part numbers see [page N13](#).

\*DIN 7154 tolerances fall within ream tolerances.

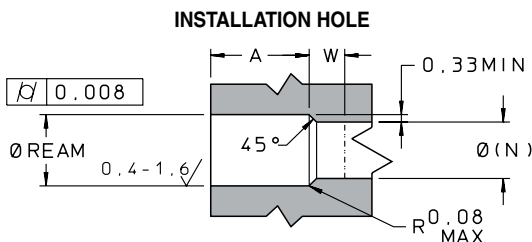

LEE PART NUMBER	4,00		4,50	
	SHORT PLGM 0400020A	LONG PLGM 0401020A	SHORT PLGM 0450020A	LONG PLGM 0451020A
D Max.	4,00	4,00	4,50	4,50
D Min.	3,98	3,98	4,48	4,48
C Nom.	4,09	6,63	4,55	7,19
M Nom.	3,40	6,10	3,81	6,61
K Nom.	3,14	3,15	3,64	3,62
L Nom.	2,96	5,48	3,29	5,15
Weight (gr.)	0,36	0,61	0,51	0,84
	<b>PROOF PRESSURE (MPa)</b>			
CLASS 1	83	123	83	123
CLASS 2	98	167	98	167
CLASS 3	113	196	113	196
	<b>REAM DIAMETERS</b>			
CLASS 1	H10* 4,00 - 4,06		H10* 4,50 - 4,56	
CLASS 2	H9* 4,00 - 4,04		H9* 4,50 - 4,54	
CLASS 3	H7* 4,00 - 4,01		H7* 4,50 - 4,51	
A Min.	3,9	6,6	4,3	7,1
N Dia. Ref.	3,2	3,2	3,7	3,7
W Min.	1,6	1,6	1,6	1,6

<b>MATERIALS</b>	
PIN & PLUG: 416 CRES Per QQ-S-763C, R <sub>c</sub> 20-34	
<b>FINISH</b>	
PIN: Passivated & Wax	
PLUG: Passivated	

For installation/extraction procedure see [page N4 – N9](#). For tool set part numbers see [page N13](#).

\*DIN 7154 tolerances fall within ream tolerances.

A

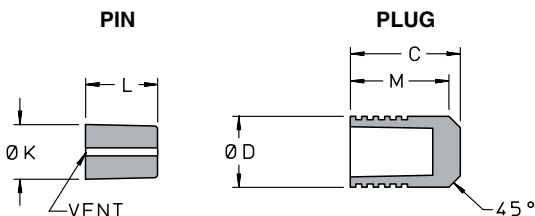

LEE PART NUMBER	5,00		5,50	
	SHORT PLGM 0500020A	LONG PLGM 0501020A	SHORT PLGM 0550020A	LONG PLGM 0551020A
D Max.	5,00	5,00	5,50	5,50
D Min.	4,98	4,98	5,48	5,48
C Nom.	4,98	7,75	5,36	8,31
M Nom.	4,22	7,12	4,60	7,62
K Nom.	4,15	4,15	4,65	4,64
L Nom.	3,72	6,47	4,08	6,87
Weight (gr.)	0,71	1,1	0,92	1,4
<b>PROOF PRESSURE (MPa)</b>				
CLASS 1	83	123	69	108
CLASS 2	98	167	83	147
CLASS 3	113	196	98	177
<b>REAM DIAMETERS</b>				
CLASS 1	H10*	5,00 - 5,06	H10*	5,50 - 5,56
CLASS 2	H9*	5,00 - 5,04	H9*	5,50 - 5,54
CLASS 3	H7*	5,00 - 5,01	H7*	5,50 - 5,51
A Min.	4,7	7,6	5,1	8,1
N Dia. Ref.	4,2	4,2	4,7	4,7
W Min.	1,6	1,6	1,6	1,6

**MATERIALS**PIN & PLUG: 416 CRES Per QQ-S-763C, R<sub>c</sub> 20-34**FINISH**

PIN: Passivated &amp; Wax

PLUG: Passivated

For installation/extraction procedure see [page N4 – N9](#). For tool set part numbers see [page N13](#).

\*DIN 7154 tolerances fall within ream tolerances.

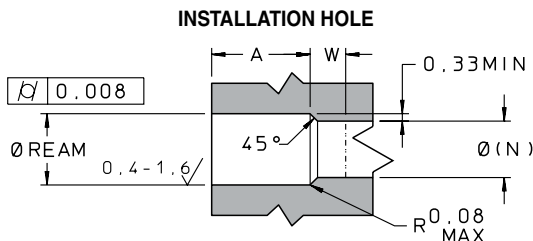

LEE PART NUMBER	6,00		6,50	
	SHORT PLGM 0600020A	LONG PLGM 0601020A	SHORT PLGM 0650020A	LONG PLGM 0651020A
D Max.	6,00	6,00	6,50	6,50
D Min.	5,98	5,98	6,48	6,48
C Nom.	5,77	8,84	6,30	9,40
M Nom.	5,01	8,11	5,52	8,62
K Nom.	5,14	5,14	5,64	5,64
L Nom.	4,28	7,24	4,69	7,49
Weight (gr.)	1,2	1,8	1,5	2,3
<b>PROOF PRESSURE (MPa)</b>				
CLASS 1	69	108	69	108
CLASS 2	83	147	83	147
CLASS 3	98	177	98	172
<b>REAM DIAMETERS</b>				
CLASS 1	H10* 6,00 - 6,06		H10* 6,50 - 6,56	
CLASS 2	H9* 6,00 - 6,04		H9* 6,50 - 6,54	
CLASS 3	H6* 6,00 - 6,01		H6* 6,50 - 6,51	
A Min.	5,5	8,6	6,0	9,1
N Dia. Ref.	5,2	5,2	5,7	5,7
W Min.	1,6	1,6	1,6	1,6

<b>MATERIALS</b>	
PIN & PLUG: 416 CRES Per QQ-S-763C, R <sub>c</sub> 20-34	
<b>FINISH</b>	
PIN: Passivated & Wax	
PLUG: Passivated	

For installation/extraction procedure see [page N4 – N9](#). For tool set part numbers see [page N14](#).  
\*DIN 7154 tolerances fall within ream tolerances.

A

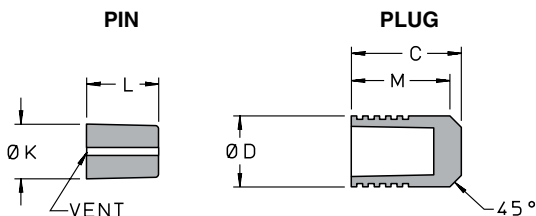

LEE PART NUMBER	7,00		7,50	
	SHORT PLGM 0700020A	LONG PLGM 0701020A	SHORT PLGM 0750020A	LONG PLGM 0751020A
D Max.	7,00	7,00	7,50	7,50
D Min.	6,98	6,98	7,48	7,48
C Nom.	6,73	9,93	7,19	10,49
M Nom.	5,92	9,12	6,30	9,61
K Nom.	6,14	6,14	6,64	6,64
L Nom.	5,05	8,13	5,39	8,51
Weight (gr.)	1,8	2,8	2,2	3,4
<b>PROOF PRESSURE (MPa)</b>				
CLASS 1	69	98	69	98
CLASS 2	83	137	83	137
CLASS 3	98	167	98	167
<b>REAM DIAMETERS</b>				
CLASS 1	H10* 7,00 - 7,06		H10* 7,50 - 7,56	
CLASS 2	H9* 7,00 - 7,04		H9* 7,50 - 7,54	
CLASS 3	H6* 7,00 - 7,01		H6* 7,50 - 7,51	
A Min.	6,4	9,6	6,8	10,1
N Dia. Ref.	6,2	6,2	6,7	6,7
W Min.	1,6	1,6	1,6	1,6

**MATERIALS**PIN & PLUG: 416 CRES Per QQ-S-763C, R<sub>c</sub> 20-34**FINISH**

PIN: Passivated &amp; Wax

PLUG: Passivated

For installation/extraction procedure see page N4 – N9. For tool set part numbers see page N14.

\*DIN 7154 tolerances fall within ream tolerances.

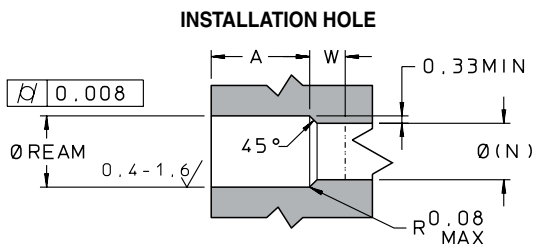

LEE PART NUMBER	8,00			
	SHORT PLGM 0800020A	LONG PLGM 0801020A		
D Max.	8,00	8,00		
D Min.	7,98	7,98		
C Nom.	7,62	11,05		
M Nom.	6,74	10,11		
K Nom.	7,14	7,10		
L Nom.	5,69	9,02		
Weight (gr.)	2,8	4,1		
<b>PROOF PRESSURE (MPa)</b>				
CLASS 1	69	98		
CLASS 2	83	123		
CLASS 3	98	152		
<b>REAM DIAMETERS</b>				
CLASS 1	H10*	8,00 - 8,06		
CLASS 2	H9*	8,00 - 8,04		
CLASS 3	H6*	8,00 - 8,01		
A Min.	7,2	10,6		
N Dia. Ref.	7,2	7,2		
W Min.	1,6	1,6		

<b>MATERIALS</b>	
PIN & PLUG: 416 CRES Per QQ-S-763C, R <sub>c</sub> 20-34	
<b>FINISH</b>	
PIN: Passivated & Wax	
PLUG: Passivated	

For installation/extraction procedure see page N4 – N9. For tool set part numbers see page N14.

\*DIN 7154 tolerances fall within ream tolerances.

A

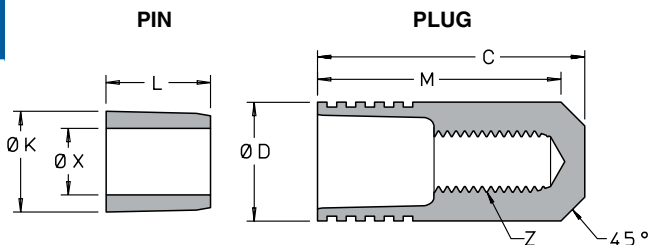

LEE PART NUMBER	156	187	218	
	PLRA 1560010A	PLRA 1870010A	PLRA 2180010A	
D Max.	.1562	.1875	.2187	
D Min.	.1553	.1866	.2178	
C Nom.	.417	.500	.500	
M Nom.	.380	.460	.460	
K Nom.	.125	.154	.180	
L Nom.	.115	.150	.150	
X	.090	.105	.117	
Z	.086-64	.099-56	.112-48	
Weight (gr.)	.30	.57	.80	
	<b>PROOF PRESSURE (psi)</b>			
CLASS 2	5000	5000	5000	
CLASS 3	6000	6000	6000	
	<b>REAM DIAMETERS</b>			
CLASS 2	.1562 - .1577	.1875 - .1890	.2187 - .2202	
CLASS 3	.1562 - .1567	.1875 - .1880	.2187 - .2192	
A Min.	.16	.17	.17	
B Min.	.06	.07	.08	

**MATERIALS**

PIN: 416 CRES per QQ-S-763C

PLUG: 2024-T4 or T351 aluminum per SAE AMS-QQ-A-225/6

**FINISH**

PIN: Passivated

PLUG: Anodize Green per MIL-A-8625 Type II B

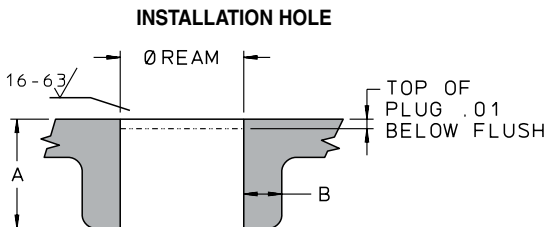

LEE PART NUMBER	250	281		
	PLRA 2500010A	PLRA 2810010A		
D Max.	.2500	.2812		
D Min.	.2491	.2803		
C Nom.	.562	.562		
M Nom.	.510	.510		
K Nom.	.212	.245		
L Nom.	.220	.193		
X	.144	.190-32		
Z	.138-40	.164-36		
Weight (gr.)	1.1	1.3		
	<b>PROOF PRESSURE (psi)</b>			
CLASS 2	4000	3000		
CLASS 3	5000	4000		
	<b>REAM DIAMETERS</b>			
CLASS 2	.2500 - .2515	.2812 - .2827		
CLASS 3	.2500 - .2505	.2812 - .2817		
A Min.	.23	.24		
B Min.	.08	.09		

<b>MATERIALS</b>
PIN: 416 CRES per QQ-S-763C
PLUG: 2024-T4 or T351 aluminum per SAE AMS-QQ-A-225/6
<b>FINISH</b>
PIN: Passivated
PLUG: Anodize Green per MIL-A-8625 Type II B

A

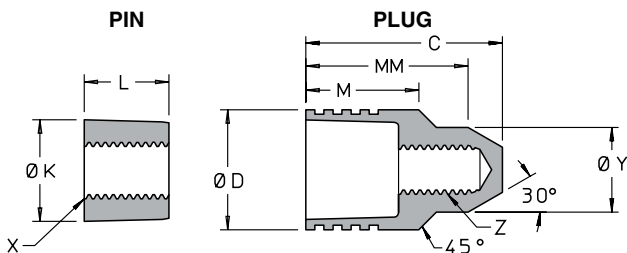

LEE PART NUMBER	343			
	PLRA 3430010A			
D Max.	.3437			
D Min.	.3428			
C Nom.	.600			
M Nom.	.320			
MM Nom.	.500			
K Nom.	.291			
L Nom.	.216			
X	.216-28			
Y Max.	.260			
Z	.190-32			
Weight (gr.)	1.8			
	<b>PROOF PRESSURE (psi)</b>			
CLASS 2	3000			
CLASS 3	4000			
	<b>REAM DIAMETERS</b>			
CLASS 2	.3437 - .3452			
CLASS 3	.3437 - .3442			
A Min.	.32			
B Min.	.09			

**MATERIALS**

PIN: 416 CRES per QQ-S-763C

PLUG: 2024-T4 or T351 aluminum per SAE AMS-QQ-A-225/6

**FINISH**

PIN: Passivated

PLUG: Anodize Green per MIL-A-8625 Type II B

## INSTALLATION HOLE

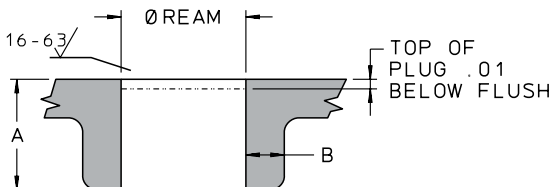

LEE PART NUMBER	406	468	500	531
	PLRA 4060010A	PLRA 4680010A	PLRA 5000010A	PLRA 5310010A
D Max.	.4062	.4687	.5000	.5312
D Min.	.4053	.4678	.4991	.5303
C Nom.	.700	.800	.870	.870
M Nom.	.400	.450	.500	.500
MM Nom.	.550	.640	.720	.720
K Nom.	.357	.428	.451	.485
L Nom.	.256	.355	.415	.375
X	.216-28	.250-28	.250-28	.250-28
Y Max.	.330	.390	.390	.390
Z	.190-32	.216-28	.216-28	.216-28
Weight (gr.)	2.4	3.7	4.6	5.2
<b>PROOF PRESSURE (psi)</b>				
CLASS 2	2500	2500	2500	2500
CLASS 3	3500	3500	3500	3500
<b>REAM DIAMETERS</b>				
CLASS 2	.4062 - .4077	.4687 - .4702	.5000 - .5015	.5312 - .5327
CLASS 3	.4062 - .4067	.4687 - .4692	.5000 - .5005	.5312 - .5317
A Min.	.40	.40	.40	.40
B Min.	.10	.10	.11	.13

## MATERIALS

PIN & PLUG: 2024-T4 or T351 aluminum per SAE AMS-QQ-A-225/6

## FINISH

PIN: Alodine Yellow per MIL-DTL-5541

PLUG: Anodize Green per MIL-A-8625 Type II B

A

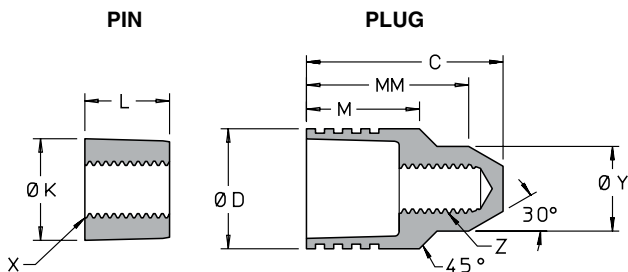

LEE PART NUMBER	656	750	875	
	PLRA 6560010A	PLRA 7500010A	PLRA 8750010A	
D Max.	.6562	.7500	.8750	
D Min.	.6553	.7491	.8741	
C Nom.	1.000	1.160	.960	
M Nom.	.600	1.100	.500	
MM Nom.	.83	.676	.720	
K Nom.	.599	.590	.801	
L Nom.	.514	.3125-24	.370	
X	.3125-24	.250-28	.375-24	
Y Max.	.420	13.0	.680	
Z	.250-28	0.095	.3125-24	
Weight (gr.)	9.2	0.066	16.0	
	<b>PROOF PRESSURE (psi)</b>			
CLASS 2	2500	2000	1500	
CLASS 3	3500	3000	2500	
	<b>REAM DIAMETERS</b>			
CLASS 2	.6562 – .6577	.7500 – .7515	.8750 – .8765	
CLASS 3	.6562 – .6567	.7500 – .7505	.8750 – .8755	
A Min.	.51	.70	.51	
B Min.	.13	.13	.15	

## INSTALLATION HOLE

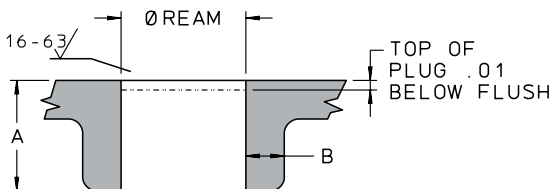
**MATERIALS**

PIN & PLUG: 2024-T4 or T351 aluminum per SAE AMS-QQ-A-225/6

**FINISH**

PIN: Alodine Yellow per MIL-DTL-5541

PLUG: Anodize Green per MIL-A-8625 Type II B

## A.F.O. PLUG

## INSTALLATION HOLE

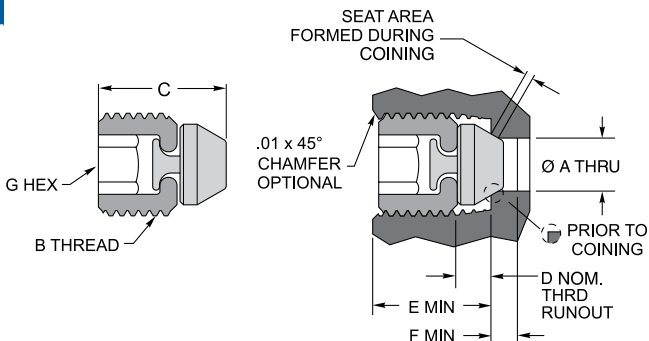

LEE PART NUMBER	190	250	312	375
	PLAA 1932010A	PLAA 2528010A	PLAA 3124010A	PLAA 3724010A
A Min.	.080	.098	.136	.187
A Max.	.098	.156	.209	.276
D Nom.	.077	.102	.119	.129
E <sup>1</sup> Min.	.295	.364	.412	.454
F Min.	.080	.070	.090	.120
Weight (gr.)	.50	1.3	2.1	3.6
	<b>PROOF PRESSURE</b> (psi x 1000)			
Stainless St.	56	56	56	54
Aluminum	26	26	26	24
AISI 8630	56	56	56	54
B Thread	.190 - 32	.250 - 28	.312 - 24	.375 - 24
C Ref.	.315	.365	.415	.455
G Hex	.094	.125	.156	.187

<sup>1</sup> Dimension (E) will vary with changes to dimension (A).

**MATERIALS**

THREADED BODY: 303 CRES per QQ-S-763C and AMS 5640 TYPE I

NOSE: 15-5 PH CRES per AMS 5659

**FINISH**

BODY AND NOSE: Passivate

## A.F.O. PLUG

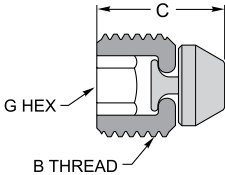

## INSTALLATION HOLE

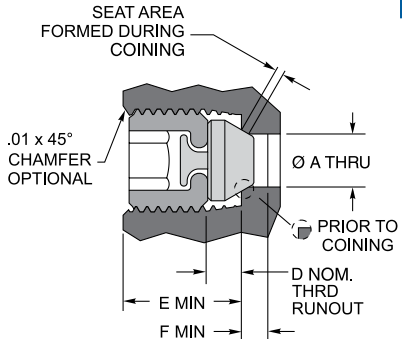

LEE PART NUMBER	500	625	750	
	PLAA 5020010A	PLAA 6218010A	PLAA 7516010A	
A Min.	.272	.384	.472	
A Max.	.386	.500	.591	
D Nom.	.150	.169	.205	
E <sup>1</sup> Min.	.550	.630	.702	
F Min.	.155	.110	.155	
Weight (gr.)	8.2	15	25	
	<b>PROOF PRESSURE (psi x 1000)</b>			
Stainless St.	54	50	50	
Aluminum	24	20	20	
AISI 8630	54	50	50	
B Thread	.500 - 20	.625 - 18	.750 - 16	
C Ref.	.550	.630	.705	
G Hex	.250	.312	.375	

<sup>1</sup> Dimension (E) will vary with changes to dimension (A).

<b>MATERIALS</b>
THREADED BODY: 303 CRES per QQ-S-763C and AMS 5640 TYPE I
NOSE: 15-5 PH CRES per AMS 5659
<b>FINISH</b>
BODY AND NOSE: Passivate

For installation procedure see [pages N21 – N22](#).

A

## NACE COMPLIANT A.F.O. PLUG

## INSTALLATION HOLE

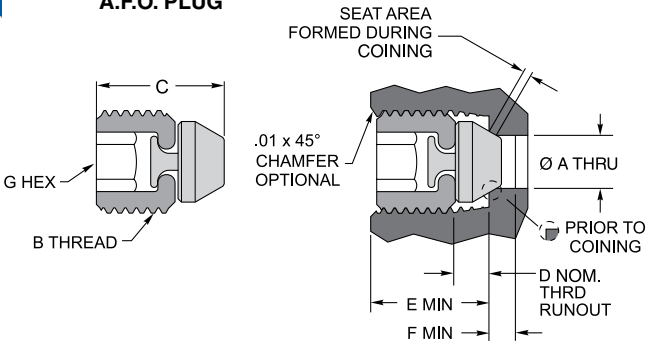

LEE PART NUMBER	190	250	312	375
	PLAA 1932020A	PLAA 2528020A	PLAA 3124020A	PLAA 3724020A
A Min.	.080	.098	.136	.187
A Max.	.098	.156	.209	.276
D Nom.	.077	.102	.119	.129
E <sup>1</sup> Min.	.295	.364	.412	.454
F Min.	.080	.070	.090	.120
Weight (gr.)	.50	1.3	2.1	3.6
	<b>PROOF PRESSURE (psi x 1000)</b>			
Stainless St.	56	56	56	54
Aluminum	26	26	26	24
AISI 8630	56	56	56	54
B Thread	.190 - 32	.250 - 28	.312 - 24	.375 - 24
C Ref.	.315	.365	.415	.455
G Hex	.094	.125	.156	.187

<sup>1</sup> Dimension (E) will vary with changes to dimension (A).

## MATERIALS

BODY AND NOSE: MP35N per NACE MR0175 / ISO 15156

## NACE COMPLIANT A.F.O. PLUG

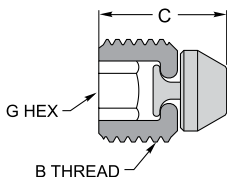

## INSTALLATION HOLE

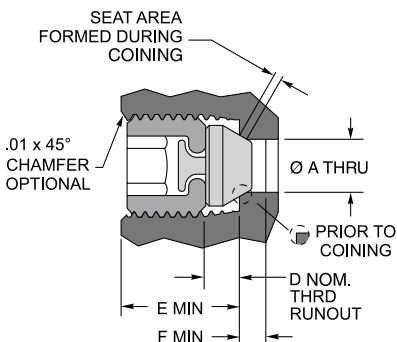

LEE PART NUMBER	500	625	750	
	PLAA 5020020A	PLAA 6218020A	PLAA 7516020A	
A Min.	.272	.384	.472	
A Max.	.386	.500	.591	
D Nom.	.150	.169	.205	
E <sup>1</sup> Min.	.550	.630	.702	
F Min.	.155	.110	.155	
Weight (gr.)	8.2	15	25	
	<b>PROOF PRESSURE (psi x 1000)</b>			
Stainless St.	54	50	50	
Aluminum	24	20	20	
AISI 8630	54	50	50	
B Thread	.500 - 20	.625 - 18	.750 - 16	
C Ref.	.550	.630	.705	
G Hex	.250	.312	.375	

<sup>1</sup> Dimension (E) will vary with changes to dimension (A).

## MATERIALS

BODY AND NOSE: MP35N per NACE MR0175 / ISO 15156

## DUAL SEALING A.F.O. PLUG

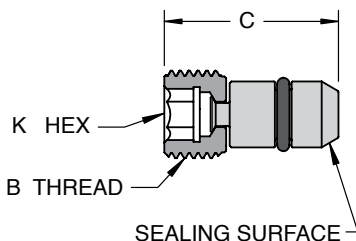

LEE PART NUMBER	500	750
	PLAA 5020110A	PLAA 7516110A
A Min.	0.308	0.526
A Max.	0.318	0.536
B Thread	500 - 20	750 - 16
C Ref.	0.967	1.269
D Nom.	0.476	0.634
E Nom.	0.156	0.195
F Nom.	0.487	0.608
G Nom.	0.100	0.125
H Max.	0.070	0.100
I Nom.	0.530	0.780
J Min.	0.375	0.625
J Max.	0.377	0.627
K Hex.	0.250	0.375
Weight (gr.)	13.0	46.0

## INSTALLATION HOLE

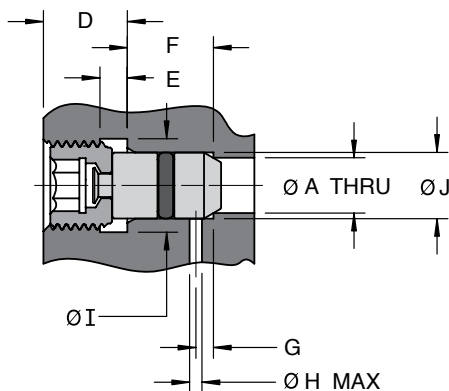

LEE PART NUMBER		500	750
		PLAA 5020110A	PLAA 7516110A
		PROOF PRESSURE (psi x 1000)	
Stainless Steel	Closed	54	50
	Open	1.5	1.5
AISI 8630	Closed	54	50
	Open	1.5	1.5
Aluminum	Closed	24	20
	Open	1.5	1.5

MATERIALS
THREADED BODY: 303 CRES per QQ-S-763C and AMS 5640 TYPE 1
NOSE: 15-5 CRES per AMS 5659
O-RING: FKM with DUROMETER 70-80
FINISH
BODY AND NOSE: Passivate

## DUAL SEALING A.F.O. PLUG

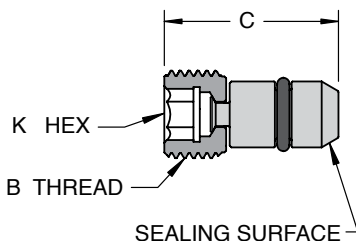

LEE PART NUMBER	500	750
	PLAA 5020120A	PLAA 7516120A
A Min.	0.308	0.526
A Max.	0.318	0.536
B Thread	500 - 20	750 - 16
C Ref.	0.967	1.269
D Nom.	0.476	0.634
E Nom.	0.156	0.195
F Nom.	0.487	0.608
G Nom.	0.100	0.125
H Max.	0.070	0.100
I Nom.	0.530	0.780
J Min.	0.375	0.625
J Max.	0.377	0.627
K Hex.	0.250	0.375
Weight (gr.)	13.0	46.0

### INSTALLATION HOLE

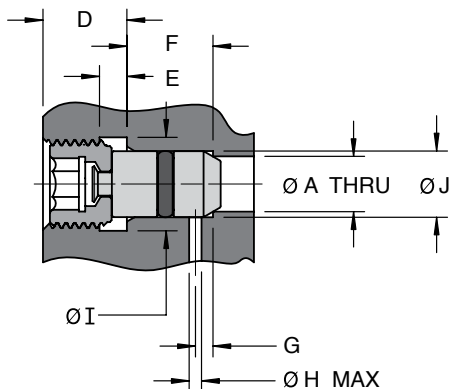

LEE PART NUMBER		500	750
		PLAA 5020120A	PLAA 7516120A
		PROOF PRESSURE (psi x 1000)	
Stainless Steel	Closed	54	50
	Open	1.5	1.5
AISI 8630	Closed	54	50
	Open	1.5	1.5
Aluminum	Closed	24	20
	Open	1.5	1.5

### MATERIALS

BODY AND NOSE: MP35N per NACE MR0175/ISO 15156

O-RING: FKM with 70-80 durometer

### FINISH

BODY AND NOSE: Passivate

A

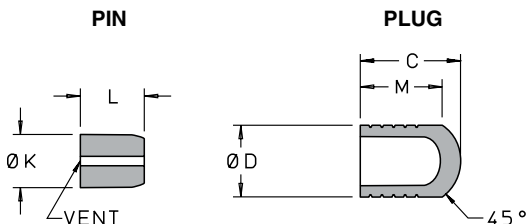

LEE PART NUMBER	093	125	156	187
	PLHA 0931241A	PLHA 1251241A	PLHA 1561241A	PLHA 1871241A
D Max.	.0937	.1250	.1562	.1875
D Min.	.0928	.1241	.1553	.1866
C Nom.	.134	.174	.214	.254
M Nom.	.106	.142	.178	.218
K Nom.	.067	.092	.122	.152
L Nom.	.083	.111	.139	.166
Weight (gr.)	.09	.24	.45	.79
<b>PROOF PRESSURE (psi x 1000)</b>				
	32	32	32	32
<b>REAM DIAMETERS</b>				
	.0937 - .0947	.1250 - .1260	.1562 - .1572	.1875 - .1885
A Min.	.122	.161	.198	.233
N Dia. Ref.	.062	.093	.125	.156
W Min.	.060	.060	.060	.060

**MATERIALS**

PIN &amp; PLUG: 15-5 PH CRES per AMS 5659

**FINISH**

PIN: Passivated &amp; Wax

PLUG: Passivated/Chromium Composite

## INSTALLATION HOLE

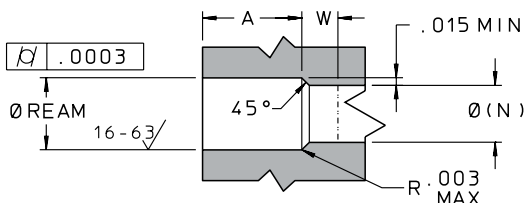

LEE PART NUMBER	218	250	281	312
	PLHA 2181241A	PLHA 2501241A	PLHA 2811241A	PLHA 3121241A
D Max.	.2187	.2500	.2812	.3124
D Min.	.2178	.2491	.2803	.3115
C Nom.	.290	.331	.369	.407
M Nom.	.248	.285	.320	.355
K Nom.	.182	.211	.241	.272
L Nom.	.194	.222	.250	.278
Weight (gr.)	1.2	1.8	2.6	3.5
	<b>PROOF PRESSURE (psi x 1000)</b>			
	32	32	32	32
	<b>REAM DIAMETERS</b>			
	.2187 - .2197	.2500 - .2510	.2812 - .2822	.3124 - .3134
A Min.	.268	.305	.340	.375
N Dia. Ref.	.187	.218	.250	.281
W Min.	.060	.060	.060	.060

## MATERIALS

PIN & PLUG: 15-5 PH CRES per AMS 5659

## FINISH

PIN: Passivated & Wax

PLUG: Passivated/Chromium Composite

A

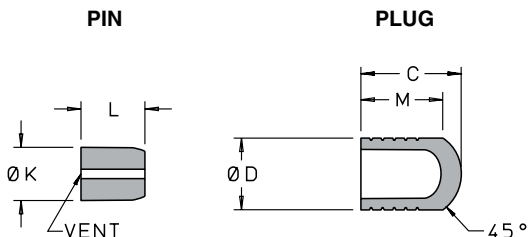

LEE PART NUMBER	343	
	PLHA 3431241A	
D Max.	.3437	
D Min.	.3428	
C Nom.	.445	
M Nom.	.390	
K Nom.	.302	
L Nom.	.305	
Weight (gr.)	4.7	
	PROOF PRESSURE (psi x 1000)	
	32	
	REAM DIAMETERS	
	.3437 - .3447	
A Min.	.410	
N Dia. Ref.	.312	
W Min.	.060	

### MATERIALS

PIN & PLUG: 15-5 PH CRES per AMS 5659

### FINISH

PIN: Passivated & Wax

PLUG: Passivated /Chromium Composite

## INSTALLATION HOLE

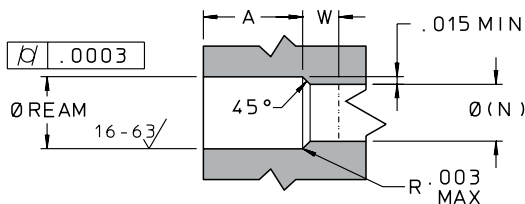
**Lee Plug Jets**

Lee Plug Jets offer an economical solution for fluid metering applications that do not require the accuracy, removability, or protective screens that are available in other, more sophisticated Lee Restrictors. Lee Plug Jets are available in 416 Stainless Steel material in body diameters of 0.125, 0.187 and 0.250 inch, with chamfered orifices of 0.010 inch through 0.093 inch in diameter. A complete specification sheet is available on request. Flow performance may be estimated by converting the orifice diameter of the Lee Plug Jet into Lohms as shown on the graph on [page O4](#).

**Lee Plug Jets cannot be manufactured from Lee Plugs as the passivation, the wax coating on the pin, and the tapered expansion surfaces would be adversely affected. Any such rework of Lee Plugs is not a recommended practice and will void our warranty.**

# Lee Restrictors

B





- Wide Range of Metered Lohm Rates Available
- Integral Safety Screens
- Available in  $\pm 2\%$  or  $\pm 5\%$  Tolerances



- Large Minimum Passage Sizes
- Reduces Contamination Problems
- Provides Viscosity Compensation
- Prevents Cavitation
- Reduces Erosion
- Available in a Wide Variety of Body Sizes
- High Pressure Units Available

## TABLE OF CONTENTS

<b>Lee Jet</b>	Single-stage restrictor 800 – 30,000 Lohms ..... 4, 16 – 23
<b>Lee High Watt Jet</b>	Single-stage restrictor 200 – 1,000 Lohms ..... 4, 24 – 25
<b>Lee Kilowatt Jet</b>	Single-stage restrictor 90 – 200 Lohms ..... 4, 26 – 27
<b>Lee Micro Jet</b>	Single-stage restrictor 475 – 3,100 Lohms ..... 4, 28 – 31
<b>Lee Bender Jet</b>	Multi-Orifice Restrictor 1,900 – 9,500 Lohms ..... 5, 32 – 33
<b>Lee Axial Visco Jet</b>	Multi-Orifice Restrictor 680 – 11,000 Lohms ..... 5, 34 – 41
<b>Lee JEVA</b>	Visco Jet, 93 Contiguous Lohm rates. 3,520 – 313,000 Lohms ..... 6, 42 – 45
<b>Lee Visco Jet</b>	Highest Lohm Rates. Up to 0.062" passage sizes. 1,370 – 2,200,000 Lohms ..... 6, 46 – 51
<b>Lee 5k Jet</b>	Single-stage restrictor 1,000 – 20,000 Lohms ..... 12, 52 – 55
<b>Lee High Pressure High Watt Jet</b>	High Pressure Screened Restrictor 350 – 3,000 Lohms ..... 12, 56 – 59
<b>Lee High Pressure Bender Jets</b>	High Pressure Multi-Orifice Restrictors 125 – 9,500 Lohms ..... 12, 60 – 69
<b>Lee High Pressure Visco Jet</b>	.125" and .187" diameter High Pressure Visco Jet. 11,200 – 313,000 Lohms ..... 12, 70 – 73
<b>5K Lee JEVA</b>	.187 diameter, 3,520 – 313,000 Lohms ..... 12, 74 – 77

Lee Company restrictors have become the accepted “standards” worldwide. Design engineers find their small size, light weight, and proven reliability are indispensable when the flow of fluids has to be controlled.

Our miniature precision flow restrictors are specified by manufacturers of aircraft hydraulic and fuel control systems, oil drilling equipment, missile controls, machine tools, and countless other products. Lee restrictors are a vital part of almost every military and commercial aircraft manufactured in the world. By employing already proven and qualified Lee restrictors in their designs, design engineers are using their own time and talents much more productively.

Lee offers a wide selection of single-stage or multi-stage orifices. Lee Jets, High Watt and Kilowatt Jets, and the Lee Micro Jet are all single orifice restrictors. Lee High Watt and Kilowatt Jets handle low Lohm rates (high flow rates) while higher Lohm rates (lower flow rates) are covered by Lee Jets.

The multi-orifice restrictors consist of Bender Jets and many different versions of the Visco Jet. Bender Jets employ several non-coaxial orifices in series using bending and multiple orifices to increase restriction. The Visco Jet adds the dimension of spin chambers for even higher restriction. Visco Jets range from small inserts all the way up to large cartridge versions, offering many options in minimum passage, Lohm rate and size.

Also available is a complete range of high pressure restrictors: Jets, High Watt Jets, Bender Jets and Visco Jets. Lee offers a restrictor for every application!

### **LEE JETS**

Lee Jets are the simplest, most accurate, most economical jets ever developed! You simply insert Lee Jets into reamed holes and lock and seal them by pressing the pin into the body. You specify either the flow and pressure drop or use the Lohm system. Lee Jets do the rest. Quick, easy installation eliminates costly assemblies, seals, threads, flow testing and filter design. The Lee Company 100% flow tests all Lee Jets to two standard tolerances,  $\pm 2\%$  and  $\pm 5\%$ .

Each Lee Jet unit contains a calibrated orifice, two matched safety screens so you can flow in both directions, and the reliable locking and sealing device adapted from Lee Plugs, which have been accepted for years as the best way to seal drilled holes.

Lee Jets are available from stock in a wide range of 53 Lohm ratings from 800 to 30,000 Lohms. Lee Jets improve your design saving time, space and money.

### **HIGH WATT and KILOWATT JETS**

Lee High Watt and Kilowatt Jets provide accurate, screened, bidirectional metered flow in the 90 to 1,000 Lohm range. The integral screens are machined and drilled from bar stock for maximum strength and erosion resistance. Due to their rugged construction, they can readily withstand the high power dissipation that is often associated with low Lohm applications. For instance, a 200 Lohm JEHA1875200L dissipates 9.6 horsepower, or 7.1 kilowatts, at 3,000 psi differential. Use these strong High Watt and Kilowatt Jets for all low Lohm (high flow) applications. Lee High Watt Jets are available in  $\pm 2\%$  and  $\pm 5\%$  tolerances and Kilowatt Jets in a  $\pm 5\%$  Lohm rate tolerance.

### **MICRO JETS**

Lee Micro Jets are precision calibrated orifices designed for flow balancing in liquid cooling applications where system pressures are below 500 psid. Lohm rates range

from 475 to 3,100 Lohms and Micro Jets are 100% flow tested to a  $\pm 2\%$  tolerance, unidirectionally. Lee Micro Jets are protected in the flow direction by an integral safety screen and are also easily installed and extracted, facilitating easy flow balancing.

Lee Micro Jets are easily installed into heat exchanger return ports. Their small size allows them to be located directly behind quick disconnect fittings.

### **BENDER JETS**

The Lee Bender Jets incorporate multiple orifices in series, with successive orifices on the centerline and displaced from it, to force fluid to “bend” as it passes through the unit. The combined effect is an increase in the orifice size for a given Lohm rate. The orifices are bigger than a single orifice, but not as large as the passageways in a Lee Visco Jet. All units are protected with two integral safety screens for bi-directional flow, and are available calibrated to a  $\pm 5\%$  tolerance in the 125 to 9,500 Lohm range.

### **AXIAL VISCO JETS**

The Lee Axial Visco Jet also uses multiple orifices in series, but uses spinning to increase Lohm rate. Spinner discs alternately reverse the direction of spin of the fluid. The result is a larger passage size than a Bender Jet for a given Lohm rate but smaller than a Visco Jet. Rugged screens protect the orifice in both flow directions. Axial Visco Jets are available calibrated to a  $\pm 5\%$  tolerance in the 680 to 11,000 Lohm range.

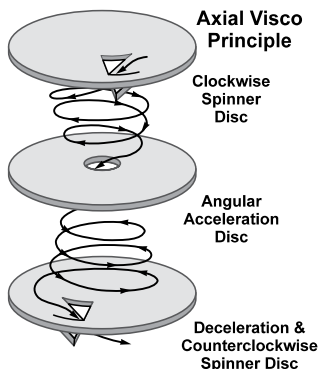

## VISCO JETS

Lee Visco Jets come in two insert versions (18-Series and the JEVA) and two cartridge sizes (43-Series and 68-Series). The 18-Series Visco Jet is an insert with 12 different Lohm rates from 11,200 to 313,000 Lohms. The JEVA is a radically new version of the 18-Series Visco Jet. It incorporates vastly increased minimum passage sizes for corresponding Lohm rates: up to 90% increase over some existing 18-Series units. In addition, 93 Lohm rates completely cover an extended range from 3,520 to 313,000 Lohms.

The 43-Series and 68-Series Visco Jets are cartridge mount units that offer the largest minimum passage for a given Lohm rate as well as the highest Lohm rates available. For instance, a 19,600 Lohm 68-Series Visco has a minimum passage of 0.032 inch. A 19,600 Lohm single orifice would be about 0.006 inch in diameter. One of the 43-Series Viscos offers a Lohm rate of 2,200,000 Lohms, with a 0.005 inch minimum passage, the equivalent of a 0.0006 inch diameter single orifice.

All Lee Visco Jets are available calibrated to a  $\pm 5\%$  or  $\pm 10\%$  tolerance. Visco Jets with minimum passageways of 0.032 inch or less are protected with two safety screens for bi-directional flow applications.

## THE PRINCIPLE BEHIND THE UNIQUE LEE VISCO JET PERFORMANCE

The Visco Jet consists basically of three discs mounted one upon the other to form an extremely complex fluid passage. Fluid enters at the center of one disc and passes through a slot which is tangential to a spin chamber. This discharges through a small center hole into

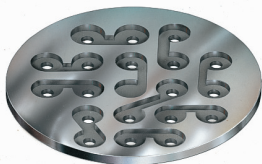

another chamber. This process repeats over and over. Since the spinning liquid makes many revolutions in each spin chamber, the resulting fluid resistance uses the flow passage surfaces many times. The tangential nature of the slots overcomes sensitivity to viscosity. The centrifugal force of the liquid maintains a back pressure on the discharge of the slot which is proportional to the square of the RPM of the spinning liquid.

This provides a reasonable degree of viscosity compensation without the use of any moving parts.

Some Lee Visco Jets are made from solid stainless steel discs, while others are fabricated from photo-etched stainless steel plates which are bonded together to produce a homogeneous leak-proof product. All Visco elements are rigidly and permanently retained in their respective inserts, cartridges, or linemounts. Standard Lee Visco Jets are calibrated to the noted Lohm ratings in both directions.

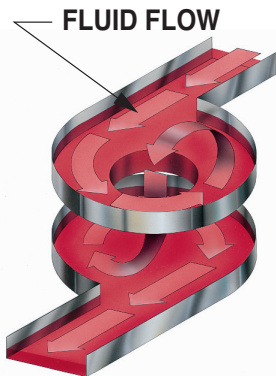

## REDUCES CLOGGING

There are always some particles of dirt or metal or lint in any hydraulic system even after it has been cleaned and filtered. Sometimes the hydraulic equipment actually generates these particles due to moving parts and there are always many more small particles than there are large ones. The size and number of these particles limit the orifice size which can be used for fluid restrictors. If a small orifice clogs, it usually means failure of a complete system.

The use of the Lee Visco Jet enables you to use much larger passages and still obtain the same amount of restriction which your system demands. Since the

minimum passageways in the Lee Visco Jet are larger than for an ordinary orifice, it also means that the hole size in protecting screens may be made proportionately larger. With both larger passageways and larger screen hole sizes, your system will tolerate a much higher level of contamination. Any particle which will pass through the screens, which we use to protect our Visco Jets, will also pass right through the Visco Jet without causing any blockage or build-up of fluid restriction. Now you can use the fluid resistance values you need without fear of system failure due to contamination.

### LOHMS VERSUS HOLE SIZE

An example of this is shown by a Visco Jet having 0.015 inch diameter holes and flowing at the same Lohm rate (32,600 Lohms) as the Standard Lee Jet having 0.0048 inch hole size. Thus the same Lohm rate can be obtained with 3.1 times the hole diameter and over 9 times the hole area!

### TO PREVENT CLOGGING YOU NEED LARGER HOLES Compare these values:

HOLE SIZE	0.005	0.015	0.032	0.055
Lohms for standard Lee Jet	28,000	3200	700	220
Lohms for 1 Stage Lee Visco Jet	145,000	32,600	8800	4000
Lohms for 5 Stage Lee Visco Jet	313,000	73,000	19,600	8900

If you need a high Lohm rate Jet, but are concerned with the possibility of clogging, even when protected by safety screens, you can get the same resistance to flow (Lohms) by using a Visco Jet with holes FIVE TIMES AS LARGE!



**NORMAL  
METERING  
HOLE**

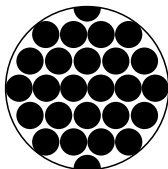

**Comparable area of flow passage  
(25 times greater) using Visco-Jet  
with SAME Lohm rate.**

## **REDUCES EROSION**

The unique Lee Visco Jet principle can provide an increase in flow passage as great as 25 times that of a corresponding (same Lohm rate) single stage restrictor, with a corresponding reduction in velocity. Since erosion is a function of the square of the velocity of the liquid medium, erosion can be reduced to 1/625 of that of the simple restrictor. Actual life tests have indicated that under certain conditions, a Lee Visco Jet can be expected to function without an appreciable change in Lohm rating for up to 20 years of continuous operation.

## **PREVENTS CAVITATION**

Liquid flowing through any orifice will cavitate whenever its velocity causes the pressure in the throat of the orifice to drop below the vapor pressure of the flowing liquid. Even though there may be a high supply pressure and a high back pressure on an orifice, if the velocity is high enough there will be a subsequent lowering of the pressure in the throat of the orifice and the possibility of cavitation.

The effects of cavitation are unstable flow and erosion – both of which are undesirable. To prevent cavitation,

sufficiently high throat pressure must be maintained, either by:

1. Applying sufficiently high back pressure or
2. Reducing the velocity of the liquid as it flows through the restrictor.

The Lee Company manufactures a wide variety of fluid restrictors constructed with orifices in series which greatly reduce the velocity and thereby permit the use of much lower back pressures (see “Cavitation” [page O29](#)).

### COMPENSATES FOR VISCOSITY

When temperature changes affect the viscosity of the hydraulic fluid, this effect usually appears dramatically in the time response of the hydraulic system. By using the Lee Visco Jet, which has a considerable amount of viscosity compensation built into the design, you will find that the time responses on hydraulic systems will remain more constant even though there are wide changes in the viscosity of the hydraulic fluids.

The curve on [page B11](#) shows the viscosity compensation of the Lee Visco Jet while flowing on MIL-H-5606 hydraulic oil. The viscosity was changed by controlling the oil temperature. Test runs were conducted with both the standard Lee Jet and a sharp edge orifice for a reference. There was no appreciable difference between the standard Lee Jet and the sharp edge orifice. However, there was a dramatic difference in the flows obtained with the Lee Visco Jet. The pressure drop was held constant throughout the runs with a  $\Delta P$  of 50 psi.

This compensation is obtained by two independent effects which tend to make the flow increase as the viscosity increases. The first effect is that of the back pressure on the spin slots. As previously mentioned, this varies as the square of the spin velocity; when the

## COMPENSATES FOR VISCOSITY

% FLOW RATE @ 50 Δ P  
MIL-H-5606 OIL

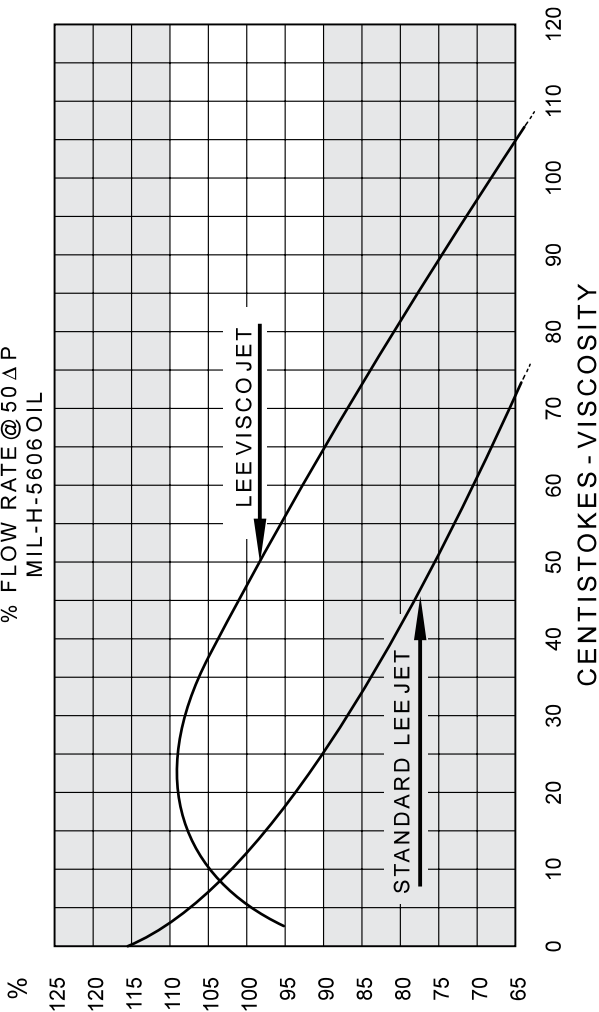

viscosity increase slows down the spin velocity, the back pressure tends to decrease, thereby permitting a higher flow through the spin slot into the spin chamber. The other effect occurs in the deceleration chamber. If the liquid is spinning at a high speed when it enters the deceleration chamber, energy is absorbed to bring this liquid to rest and subsequently to accelerate it out in the opposite direction. This shows up as a pressure drop. If, due to the increase in viscosity, the liquid is not spinning as fast when it enters the deceleration chamber, it then follows that it can be discharged with less pressure drop.

If a relatively flat flow vs. viscosity curve were desired, it can readily be obtained in the low viscosity ranges, that is up to 23 centistokes. Referring to the two curves on [page B11](#) one can see that if a standard Lee Jet and a Visco Jet were flowing in parallel, the two slopes would be cancelled out through this viscosity range and the total output would be reasonably constant for 1 centistoke through 23 centistokes. Again referring to the MIL-H-5606 oil, this would be from +72° to over 350°F.

## HIGH PRESSURE RESTRICTORS

The Lee Company offers a complete range of high pressure restrictors for system pressures up to 8,000 psi. The Lee 5k Jet and High Pressure High Watt Jets are single orifice restrictors covering Lohm rates from 1,000 to 20,000, and 350 to 3,000 Lohms, respectively. The High Pressure Bender Jets are multi-orifice restrictors covering 125 – 9,500 Lohms, and the High Pressure Visco Jets range from 3,520 Lohms to 313,000 Lohms. The High Pressure Visco Jet comes in two sizes, a 0.187" diameter and a new smaller 0.125" diameter version which offers the same performance but with a significant savings in space.

## INTERCHANGEABILITY

Lee Restrictors provide a high degree of interchangeability. Lee Jets, Bender Jets and 18-Series Visco Jets all have the same length to the seating chamfer. If space exists to accommodate some variation in overall length, a restrictor in a different range of Lohm rates or with a different minimum passage size can be chosen without changing the installation hole. The high pressure High Watts, Bender Jets and Visco Jets are interchangeable with each other.

**B**

## MASTER SETS

Master Sets are convenient sets of interchangeable Lee restrictors calibrated to tight test tolerances for use in hydraulic design evaluations. There are four different master sets available: the Lee Jet Master Set, the High Watt Jet Master Set, the Visco Jet Master Set and the Micro Jet Master Set.

Master sets contain a wide range of calibrated restrictors in individually marked vials along with installation and extraction tool sets and procedures and extra pins or o-rings. The Lee Jet, High Watt Jet and Visco Jet Master Sets also include two each of Lee “B” and “C” unions for line mount applications.

Lee Jet, High Watt Jet and Visco Jet Master Sets are bidirectionally calibrated and marked with the actual Lohm rate ( $\pm 1\%$  for Jet and High Watts,  $\pm 5\%$  for Visco Jets). Lee Micro Jet Master Sets are calibrated unidirectionally ( $\pm 2\%$ ) and supplied with actual Lohm rates on a data sheet. All Lee restrictors are readily installed and removed from hydraulic manifolds.

**MASTER SET**  
**AVAILABLE LOHM RATES**

B

LEE JET MASTER SET PART NUMBER: JETA1871000A	LEE MICRO JET MASTER SET PART NUMBER: JEMA2710000B	HIGH WATT JET MASTER SET PART NUMBER: JEHA1871000A	VISCO JET MASTER SET PART NUMBER: VDCA1871000A
800	475	200	11 200
950	515	225	17 600
1 200	555	250	24 000
1 500	600	275	33 000
1 800	650	300	40 000
2 200	700	325	50 000
3 000	760	350	60 000
4 000	820	400	70 000
5 000	885	450	80 000
6 500	955	500	100 000
8 000	1040	600	125 000
10 000	1120	700	145 000
15 000	1210	800	198 000
20 000	1310	900	243 000
30 000	1420	1000	313 000
	1530		
	1650		
	1790		
	1930		
	2090		
	2260		
	2450		
	2640		
	2860		
	3100		

**MINIMUM PASSAGE SIZE (Inches)**

LOHM RATE RANGE	LEE JET, HIGHWATT & KILOWATT JET	BENDER JET	SHORT AXIAL VISCO	LONG AXIAL VISCO	12 & 18 SERIES VISCOS	LEE JEVA	43 SERIES VISCO	68 SERIES VISCO
90 -	0.092	0.124	-	-	-	-	-	-
200	0.062	0.103	-	-	-	-	-	-
200 -	0.063	0.091	-	-	-	-	-	-
600	0.036	0.050	-	-	-	-	-	-
600 -	0.036	0.050	0.060	-	-	-	-	-
1000	0.0265	0.036	-	-	-	-	-	-
1000 -	0.0265	0.036	0.050	0.060	-	-	-	0.062
1900	0.020	0.030	0.045	0.050	-	-	-	-
1900 -	0.020	0.030	0.045	0.050	-	0.026	-	-
3700	0.014	0.020	0.035	0.040	-	-	-	-
3700 -	0.015	0.020	0.035	0.035	-	-	0.031	-
7400	0.010	0.015	0.020	0.025	-	0.026	-	-
7500 -	0.010	0.015	0.020	0.025	-	0.019	-	0.032
11000	0.0083	0.015	0.020	0.020	-	0.019	-	0.032
11000 -	0.0085	-	-	-	0.015	0.019	-	-
17600	0.0067	-	-	-	0.010	0.013	0.015	0.032
17600 -	0.0067	-	-	-	0.010	0.013	0.015	-
30000	0.0051	-	-	-	0.007	0.009	0.015	-
30200 -	0.0051*	-	-	-	0.010	0.013	0.015	-
46800	0.0041*	-	-	-	0.007	0.009	0.015	-
49100 -	0.0041*	-	-	-	0.005	0.006	-	-
130000	0.0025*	-	-	-	-	-	-	-
137000 -	0.0025*	-	-	-	0.005	-	-	-
313000	0.0016*	-	-	-	-	-	-	-
950000 -	0.0009*	-	-	-	-	-	0.005	-
2200000	0.0006*	-	-	-	-	-	0.005	-

\*Equivalent single orifice size - Lee Jets are not offered for these Lohm rates

# 16 156 Lee Jet

**B**

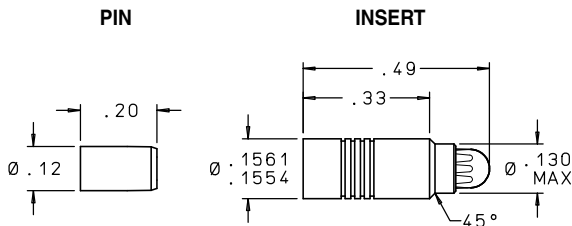

## MATERIALS

PART	MATERIAL	SPECIFICATION
Body	304 Cres	AMS 5639
Pin	15-5PH Cres	AMS 5659
Screens	304L Cres	ASTM A 666
Braze	—	AMS 4774

*Finish: All Cres Parts Passivated.*

*Pins are prewaxed. Do not degrease. Do not lubricate.*

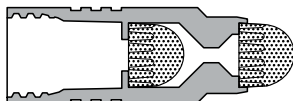

*Note: See [pages B18 – B19](#) for a complete list of Lohm rates and part numbers.*

### INSTALLATION HOLE

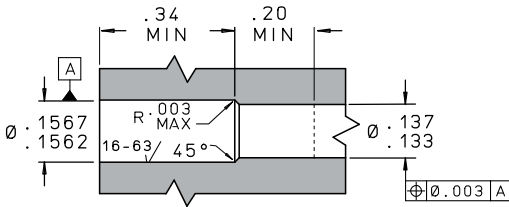

### INSTALLATION AND EXTRACTION

Tool Set Part Number ..... CUTA1560104C  
 Procedures ..... See **Pages N26 – N30**  
 Replacement Pin Part Number ..... JETA1560003B

*For boss size see **page N24**. For oversize see **page N28**.*

### PERFORMANCE

Lohm Rate Tolerance .....  $\pm 2\%$  or  $\pm 5\%$   
 Maximum Working Pressure ..... 3000 psid  
 Nominal Weight ..... 0.7 grams

B

LEE PART NUMBER		LOHM RATE	NOMINAL SCREEN HOLE SIZE (Inches)
±2%	±5%		
JETA1562300D	JETA1565300D	3000	.008
JETA1562320D	JETA1565320D	3200	.008
JETA1562340D	JETA1565340D	3400	.008
JETA1562360D	JETA1565360D	3600	.008
JETA1562380D	JETA1565380D	3800	.008
JETA1562400D	JETA1565400D	4000	.008
JETA1562430D	JETA1565430D	4300	.008
JETA1562460D	JETA1565460D	4600	.008
JETA1562500D	JETA1565500D	5000	.006
JETA1562550D	JETA1565550D	5500	.006
JETA1562600D	JETA1565600D	6000	.006
JETA1562650D	JETA1565650D	6500	.006
JETA1562700D	JETA1565700D	7000	.006
JETA1562750D	JETA1565750D	7500	.006
JETA1562800D	JETA1565800D	8000	.006
JETA1562850D	JETA1565850D	8500	.006
JETA1562900D	JETA1565900D	9000	.006

LEE PART NUMBER		LOHM RATE	NOMINAL SCREEN HOLE SIZE (Inches)
±2%	±5%		
JETA1562950D	JETA1565950D	9500	.006
JETA1562100H	JETA1565100H	10000	.006
JETA1562110H	JETA1565110H	11000	.004
JETA1562120H	JETA1565120H	12000	.004
JETA1562130H	JETA1565130H	13000	.004
JETA1562140H	JETA1565140H	14000	.004
JETA1562150H	JETA1565150H	15000	.004
JETA1562160H	JETA1565160H	16000	.004
JETA1562170H	JETA1565170H	17000	.004
JETA1562180H	JETA1565180H	18000	.004
JETA1562190H	JETA1565190H	19000	.004
JETA1562200H	JETA1565200H	20000	.004
JETA1562220H	JETA1565220H	22000	.004
JETA1562240H	JETA1565240H	24000	.004
JETA1562260H	JETA1565260H	26000	.004
JETA1562280H	JETA1565280H	28000	.004
JETA1562300H	JETA1565300H	30000	.004

# 20 187 Lee Jet

**B**

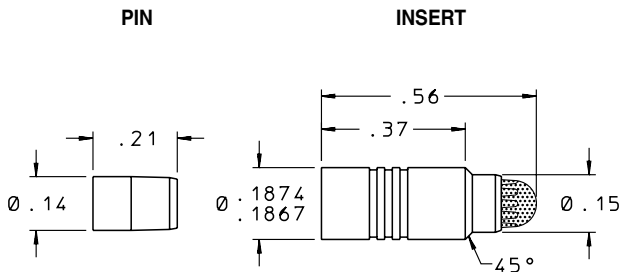

MATERIALS		
PART	MATERIAL	SPECIFICATION
Body	303 Cres	QQ-S-763C
Pin	303 Cres	QQ-S-763C
Screens	304L Cres	ASTM A 666
Base Washer	304L Cres	ASTM A 666
Braze	—	AMS 4774

*Finish: All Cres Parts Passivated.  
Pins are prewaxed. Do not degrease. Do not lubricate.*

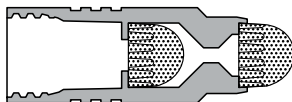

*Note: See [pages B22 – B23](#) for a complete list of Lohm rates and part numbers.*

## INSTALLATION HOLE

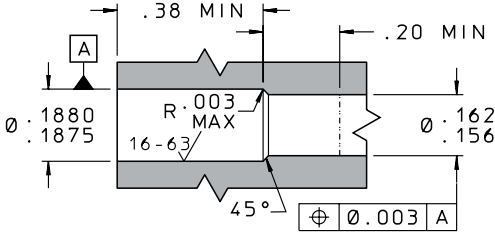

**B**

## INSTALLATION AND EXTRACTION

Tool Set Part Number .....	CUTA1870104C
Procedures .....	See <b>Pages N26 – N30</b>
Line Mount Configurations.....	See <b>Pages L6 – L8</b>
Replacement Pin Part Number.....	JETA1870003A
Master Set Part Number.....	JETA1871000A
Master Set Description .....	See <b>Pages B13 – B14</b>

*For boss size see **page N24**. For oversize see **page N28**.*

## PERFORMANCE

Lohm Rate Tolerance .....	±2% or ±5%
Maximum Working Pressure .....	3000 psid
Nominal Weight.....	1.2 grams

B

LEE PART NUMBER		LOHM RATE	NOMINAL SCREEN HOLE SIZE (Inches)
±2%	±5%		
JETA1872800L	JETA1875800L	800	0.015
JETA1872850L	JETA1875850L	850	0.015
JETA1872900L	JETA1875900L	900	0.015
JETA1872950L	JETA1875950L	950	0.015
JETA1872100D	JETA1875100D	1 000	0.008
JETA1872110D	JETA1875110D	1 100	0.008
JETA1872120D	JETA1875120D	1 200	0.008
JETA1872130D	JETA1875130D	1 300	0.008
JETA1872140D	JETA1875140D	1 400	0.008
JETA1872150D	JETA1875150D	1 500	0.008
JETA1872160D	JETA1875160D	1 600	0.008
JETA1872170D	JETA1875170D	1 700	0.008
JETA1872180D	JETA1875180D	1 800	0.008
JETA1872190D	JETA1875190D	1 900	0.008
JETA1872200D	JETA1875200D	2 000	0.008
JETA1872220D	JETA1875220D	2 200	0.008
JETA1872240D	JETA1875240D	2 400	0.008
JETA1872260D	JETA1875260D	2 600	0.008
JETA1872280D	JETA1875280D	2 800	0.008
JETA1872300D	JETA1875300D	3 000	0.008
JETA1872320D	JETA1875320D	3 200	0.008
JETA1872340D	JETA1875340D	3 400	0.008
JETA1872360D	JETA1875360D	3 600	0.008
JETA1872380D	JETA1875380D	3 800	0.008
JETA1872400D	JETA1875400D	4 000	0.008
JETA1872430D	JETA1875430D	4 300	0.008
JETA1872460D	JETA1875460D	4 600	0.008

LEE PART NUMBER		LOHM RATE	NOMINAL SCREEN HOLE SIZE (Inches)
±2%	±5%		
JETA1872500D	JETA1875500D	5 000	0.006
JETA1872550D	JETA1875550D	5 500	0.006
JETA1872600D	JETA1875600D	6 000	0.006
JETA1872650D	JETA1875650D	6 500	0.006
JETA1872700D	JETA1875700D	7 000	0.006
JETA1872750D	JETA1875750D	7 500	0.006
JETA1872800D	JETA1875800D	8 000	0.006
JETA1872850D	JETA1875850D	8 500	0.006
JETA1872900D	JETA1875900D	9 000	0.006
JETA1872950D	JETA1875950D	9 500	0.006
JETA1872100H	JETA1875100H	10 000	0.006
JETA1872110H	JETA1875110H	11 000	0.004
JETA1872120H	JETA1875120H	12 000	0.004
JETA1872130H	JETA1875130H	13 000	0.004
JETA1872140H	JETA1875140H	14 000	0.004
JETA1872150H	JETA1875150H	15 000	0.004
JETA1872160H	JETA1875160H	16 000	0.004
JETA1872170H	JETA1875170H	17 000	0.004
JETA1872180H	JETA1875180H	18 000	0.004
JETA1872190H	JETA1875190H	19 000	0.004
JETA1872200H	JETA1875200H	20 000	0.004
JETA1872220H	JETA1875220H	22 000	0.004
JETA1872240H	JETA1875240H	24 000	0.004
JETA1872260H	JETA1875260H	26 000	0.004
JETA1872280H	JETA1875280H	28 000	0.004
JETA1872300H	JETA1875300H	30 000	0.004

B

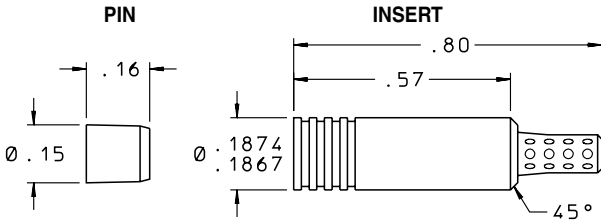

MATERIALS		
PART	MATERIAL	SPECIFICATION
Body	303 Cres	QQ-S-763C
Pin	17-4PH Cres	AMS 5643
Screens	303 Cres	QQ-S-763C
Metering Element	304 Cres	AMS QQ-S-763

*Finish: All Cres Parts Passivated.  
Pins are prewaxed. Do not degrease. Do not lubricate.*

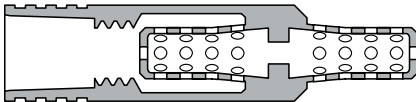

PERFORMANCE	
Lohm Rate Tolerance.....	±2% or ±5%
Maximum Working Pressure .....	4000 psid
Nominal Weight.....	1.5 grams

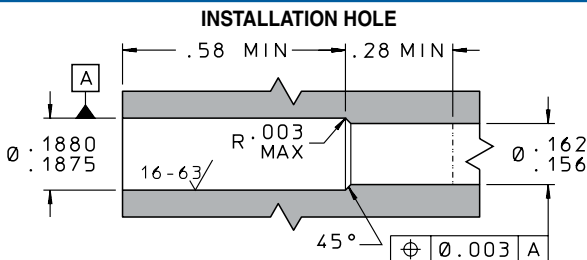

B

## INSTALLATION AND EXTRACTION

Tool Set Part Number ..... CUTA1870110C  
 Procedures ..... See **Pages N26 – N30**  
 Line Mount Configurations..... See **Pages L6 – L8**  
 Replacement Pin Part Number..... JEHA1870003A  
 Master Set Part Number..... JEHA1871000A  
 Master Set Description ..... See **Pages B13 – B14**  
*For boss size see **page N24**. For oversize see **page N28**.*

LEE PART NUMBER		LOHM RATE	NOMINAL SCREEN HOLE SIZE (Inches)
±2%	±5%		
JEHA1872200L	JEHA1875200L	200	0.030
JEHA1872225L	JEHA1875225L	225	0.030
JEHA1872250L	JEHA1875250L	250	0.030
JEHA1872275L	JEHA1875275L	275	0.030
JEHA1872300L	JEHA1875300L	300	0.030
JEHA1872325L	JEHA1875325L	325	0.030
JEHA1872350L	JEHA1875350L	350	0.024
JEHA1872375L	JEHA1875375L	375	0.024
JEHA1872400L	JEHA1875400L	400	0.024
JEHA1872425L	JEHA1875425L	425	0.024
JEHA1872450L	JEHA1875450L	450	0.024
JEHA1872475L	JEHA1875475L	475	0.024
JEHA1872500L	JEHA1875500L	500	0.024
JEHA1872550L	JEHA1875550L	550	0.020
JEHA1872600L	JEHA1875600L	600	0.020
JEHA1872650L	JEHA1875650L	650	0.020
JEHA1872700L	JEHA1875700L	700	0.020
JEHA1872750L	JEHA1875750L	750	0.020
JEHA1872800L	JEHA1875800L	800	0.015
JEHA1872850L	JEHA1875850L	850	0.015
JEHA1872900L	JEHA1875900L	900	0.015
JEHA1872950L	JEHA1875950L	950	0.015
JEHA1872100D	JEHA1875100D	1000	0.015

B

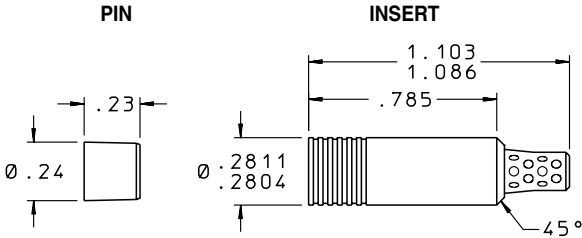

**MATERIALS**

PART	MATERIAL	SPECIFICATION	HEAT TREAT
Body	304L Cres	AMS 5647	—
Pin	15-5PH Cres	AMS 5659	H1025
Orifice Plate	15-5PH Cres	AMS 5659	H1025
Screens	15-5PH Cres	AMS 5659	H1025

*Finish: All Cres Parts Passivated.*

*Pins are prewaxed. Do not degrease. Do not lubricate.*

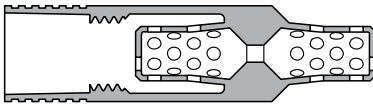

**PERFORMANCE**

Lohm Rate Tolerance.....	±5%
Maximum Working Pressure .....	3000 psid
Nominal Weight .....	4.0 grams

## INSTALLATION HOLE

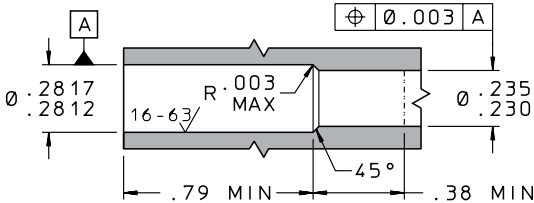

**B**

## INSTALLATION AND EXTRACTION

Tool Set Part Number ..... CUTA2810104C

Procedures ..... See **Pages N26 – N30**

Line Mount Configurations..... See **Pages L9 – L12**

Replacement Pin Part Number..... JEKA2810003B

*For boss size see **page N24**. For oversize see **page N28**.*

LEE PART NUMBER	LOHM RATE $\pm 5\%$	NOMINAL SCREEN HOLE SIZE (Inches)
JEKA2815090L	90	0.040
JEKA2815110L	110	0.040
JEKA2815130L	130	0.040
JEKA2815150L	150	0.040
JEKA2815175L	175	0.040
JEKA2815200L	200	0.040

B

INSERT

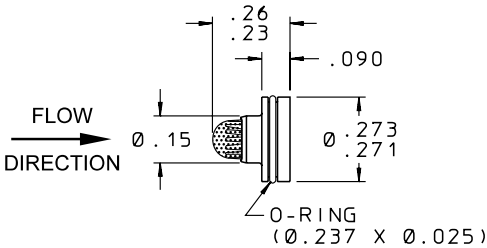

MATERIALS		
PART	MATERIAL	SPECIFICATION
Body	303 Cres	QQ-S-763C
Screen Assembly	304L Cres	ASTM A 666
Braze	—	AMS 4774
O-Ring	Fluorosilicone	—

Finish: All Cres Parts Passivated.

PERFORMANCE
Lohm Rate Tolerance..... $\pm 2\%$
Maximum Working Pressure .....500 psid
Nominal Weight.....0.44 grams

## INSTALLATION HOLE

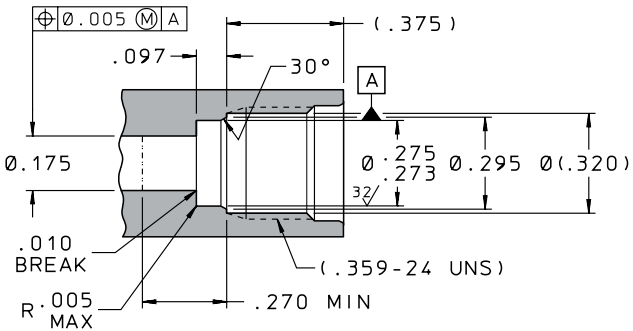

## INSTALLATION AND EXTRACTION

Tool Set Part Number ..... CUTA2711004C  
 Procedures ..... See [Page N37](#)  
 Replacement O-Ring Part Number..... HDRX0200020B  
 Master Set Part Number..... JEMA2710000B  
 Master Set Description ..... See [Pages B13 – B14](#)

B

LEE PART NUMBER	LOHM RATE ± 2%	NOMINAL SCREEN HOLE SIZE (Inches)
JEMA2712475L	475	0.015
JEMA2712495L	495	0.015
JEMA2712515L	515	0.015
JEMA2712535L	535	0.015
JEMA2712555L	555	0.015
JEMA2712575L	575	0.015
JEMA2712600L	600	0.015
JEMA2712625L	625	0.015
JEMA2712650L	650	0.015
JEMA2712675L	675	0.015
JEMA2712700L	700	0.015
JEMA2712730L	730	0.015
JEMA2712760L	760	0.015
JEMA2712790L	790	0.015
JEMA2712820L	820	0.015
JEMA2712850L	850	0.015
JEMA2712885L	885	0.015
JEMA2712920L	920	0.015
JEMA2712955L	955	0.015
JEMA2712995L	995	0.008
JEMA2712104D	1040	0.008
JEMA2712108D	1080	0.008
JEMA2712112D	1120	0.008
JEMA2712117D	1170	0.008

LEE PART NUMBER	LOHM RATE ± 2%	NOMINAL SCREEN HOLE SIZE (Inches)
JEMA2712121D	1210	0.008
JEMA2712126D	1260	0.008
JEMA2712131D	1310	0.008
JEMA2712136D	1360	0.008
JEMA2712142D	1420	0.008
JEMA2712147D	1470	0.008
JEMA2712153D	1530	0.008
JEMA2712159D	1590	0.008
JEMA2712165D	1650	0.008
JEMA2712172D	1720	0.008
JEMA2712179D	1790	0.008
JEMA2712186D	1860	0.008
JEMA2712193D	1930	0.008
JEMA2712201D	2010	0.008
JEMA2712209D	2090	0.008
JEMA2712218D	2180	0.008
JEMA2712226D	2260	0.008
JEMA2712235D	2350	0.008
JEMA2712245D	2450	0.008
JEMA2712254D	2540	0.008
JEMA2712264D	2640	0.008
JEMA2712275D	2750	0.008
JEMA2712286D	2860	0.008
JEMA2712297D	2970	0.008
JEMA2712310D	3100	0.008

**B**

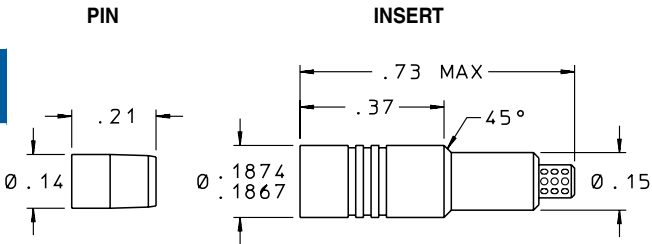

MATERIALS		
PART	MATERIAL	SPECIFICATION
Body	303 Cres	QQ-S-763C
Pin	303 Cres	QQ-S-763C
Internal Pin & Plug	303 Cres	QQ-S-763C
Spacers	303 Cres	QQ-S-763C
Metering Discs	17-7PH Cres	AMS 5529
Drilled Screens	303 Cres	QQ-S-763C
Etched Screens	304L Cres	ASTM A 666
Base Washers	304L Cres	ASTM A 666
Braze	—	AMS 4774

*Finish: All Cres Parts Passivated.  
Pins are prewaxed. Do not degrease. Do not lubricate.*

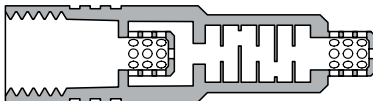

PERFORMANCE	
Lohm Rate Tolerance.....	±5%
Maximum Working Pressure .....	3000 psid
Nominal Weight.....	1.4 grams

### INSTALLATION HOLE

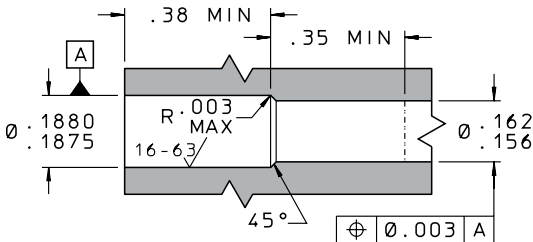

### INSTALLATION AND EXTRACTION

Tool Set Part Number ..... CUTA1870104C  
 Procedures ..... See **Pages N26 – N30**  
 Line Mount Configurations..... See **Pages L6 – L8**  
 Replacement Pin Part Number..... JETA1870003A

*For boss size see **page N24**. For oversize see **page N28**.*

LEE PART NUMBER	LOHM RATE ±5%	MINIMUM PASSAGE SIZE (Inches)	NOMINAL SCREEN HOLE SIZE (Inches)
JEBA1875190D	1900	0.030	0.020
JEBA1875240D	2400	0.030	0.020
JEBA1875330D	3300	0.025	0.015
JEBA1875370D	3700	0.020	0.015
JEBA1875500D	5000	0.020	0.015
JEBA1875590D	5900	0.020	0.015
JEBA1875710D	7100	0.015	0.008
JEBA1875950D	9500	0.015	0.008

B

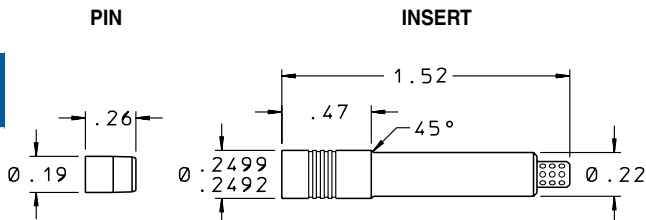

### MATERIALS

PART	MATERIAL	SPECIFICATION
Body	303 Cres	QQ-S-763C
Pin	303 Cres	QQ-S-763C
Screens	303 Cres	QQ-S-763C
Spacers	303 Cres	QQ-S-763C
Shims	303 Cres	QQ-S-763C
Spinner Discs	17-7PH Cres	AMS 5528
Metering Discs	17-7PH Cres	AMS 5529

*Finish: All Cres Parts Passivated.*

*Pins are prewaxed. Do not degrease. Do not lubricate.*

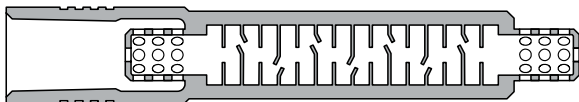

### PERFORMANCE

Lohm Rate Tolerance.....	±5%
Maximum Working Pressure .....	3000 psid
Nominal Weight.....	4.3 grams

## INSTALLATION HOLE

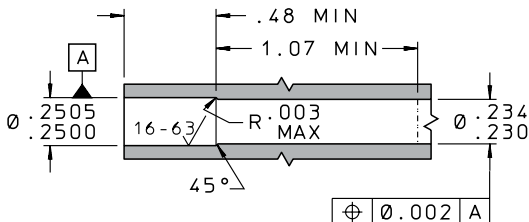

**B**

## INSTALLATION AND EXTRACTION

Tool Set Part Number ..... CUTA2500106C

Procedures ..... See **Pages N26 – N30**

Line Mount Configurations..... See **Page L13**

Replacement Pin Part Number..... CKFA2500003A

*For boss size see **page N24** For oversize see **page N28**.*

LEE PART NUMBER	LOHM RATE	NOMINAL PASSAGE SIZE (Inches)	NOMINAL SCREEN HOLE SIZE (Inches)
VXCA2502680L	680	0.060	0.031
VXCA2502910L	910	0.060	0.031
VXCA2502120D	1200	0.050	0.031
VXCA2502140D	1400	0.050	0.031
VXCA2502190D	1900	0.045	0.031
VXCA2502210D	2100	0.040	0.031

B

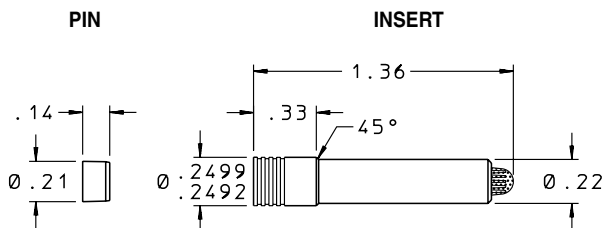

### MATERIALS

PART	MATERIAL	SPECIFICATION
Body	303 Cres	QQ-S-763C
Pin	303 Cres	QQ-S-763C
Stack Retainer	303 Cres	QQ-S-763C
Spacers	303 Cres	QQ-S-763C
Shims	303 Cres	QQ-S-763C
Spinner Discs	17-7PH Cres	AMS 5528
Metering Discs	17-7PH Cres	AMS 5529
Screens	304L Cres	ASTM A 666
Base Washer	304L Cres	ASTM A 666
Braze	—	AMS 4774

*Finish: All Cres Parts Passivated.*

*Pins are prewaxed. Do not degrease. Do not lubricate.*

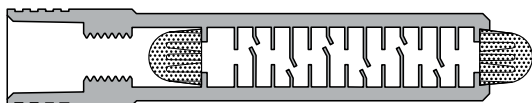

### PERFORMANCE

Lohm Rate Tolerance .....	±5%
Maximum Working Pressure .....	3000 psid
Nominal Weight.....	4.3 grams

## INSTALLATION HOLE

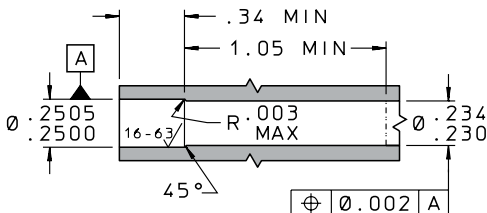

## INSTALLATION AND EXTRACTION

Tool Set Part Number ..... CUTA2000113C

Procedures ..... See **Pages N26 – N30**

Line Mount Configurations..... See **Page L13**

Replacement Pin Part Number..... VXCA2500003A

*For boss size see **page N24**. For oversize see **page N28**.*

LEE PART NUMBER	LOHM RATE	NOMINAL PASSAGE SIZE (Inches)	NOMINAL SCREEN HOLE SIZE (Inches)
VXCA2500270D	2700	0.035	0.015
VXCA2500330D	3300	0.035	0.015
VXCA2500370D	3700	0.035	0.015
VXCA2500450D	4500	0.030	0.015
VXCA2500560D	5600	0.025	0.015
VXCA2500620D	6200	0.025	0.015
VXCA2500740D	7400	0.020	0.015
VXCA2500820D	8200	0.020	0.015

B

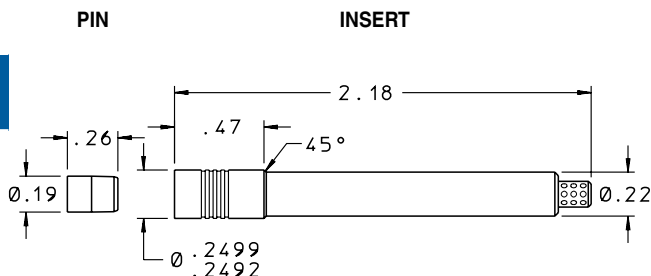

### MATERIALS

PART	MATERIAL	SPECIFICATION
Body	303 Cres	QQ-S-763C
Pin	303 Cres	QQ-S-763C
Screens	303 Cres	QQ-S-763C
Spacers	303 Cres	QQ-S-763C
Shims	303 Cres	QQ-S-763C
Spinner Discs	17-7PH Cres	AMS 5528
Metering Discs	17-7PH Cres	AMS 5529

*Finish: All Cres Parts Passivated.*

*Pins are prewaxed. Do not degrease. Do not lubricate.*

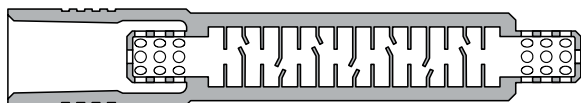

### PERFORMANCE

Lohm Rate Tolerance .....	$\pm 5\%$
Maximum Working Pressure.....	3000 psid
Nominal Weight.....	6.2 grams

## INSTALLATION HOLE

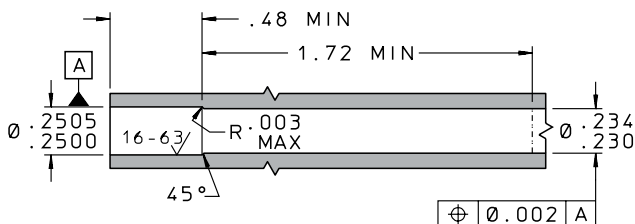

B

## INSTALLATION AND EXTRACTION

Tool Set Part Number ..... CUTA2500106C

Procedures ..... See **Pages N26 – N30**Line Mount Configurations..... See **Page L14**

Replacement Pin Part Number..... CKFA2500003A

*For boss size see **page N24**. For oversize see **page N28**.*

LEE PART NUMBER	LOHM RATE	NOMINAL PASSAGE SIZE (Inches)	NOMINAL SCREEN HOLE SIZE (Inches)
VXCA2503112D	1120	0.060	0.031
VXCA2503140D	1400	0.060	0.031
VXCA2503190D	1900	0.050	0.031
VXCA2503270D	2700	0.045	0.031
VXCA2503320D	3200	0.040	0.031

B

PIN

INSERT

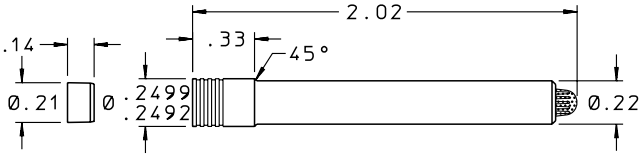

**MATERIALS**

PART	MATERIAL	SPECIFICATION
Body	303 Cres	QQ-S-763C
Pin	303 Cres	QQ-S-763C
Stack Retainer	303 Cres	QQ-S-763C
Spacers	303 Cres	QQ-S-763C
Shims	303 Cres	QQ-S-763C
Spinner Discs	17-7PH Cres	AMS 5528
Metering Discs	17-7PH Cres	AMS 5529
Screens	304L Cres	ASTM A 666
Base Washer	304L Cres	ASTM A 666
Braze	—	AMS 4774

*Finish: All Cres Parts Passivated.*

*Pins are prewaxed. Do not degrease. Do not lubricate.*

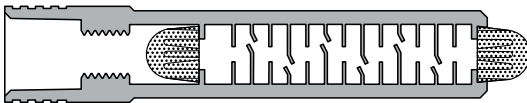

**PERFORMANCE**

Lohm Rate Tolerance .....	±5%
Maximum Working Pressure.....	3000 psid
Nominal Weight .....	6.2 grams

## INSTALLATION HOLE

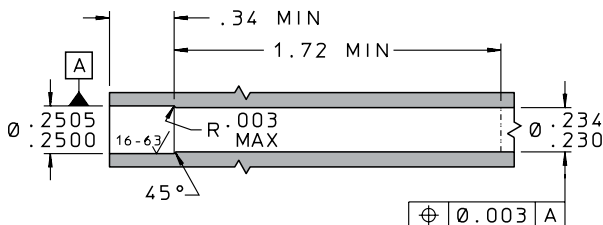

B

## INSTALLATION AND EXTRACTION

Tool Set Part Number ..... CUTA2000113C

Procedures ..... See **Pages N26 – N30**

Line Mount Configurations..... See **Page L14**

Replacement Pin Part Number..... VXCA2500003A

*For boss size see **page N24**. For oversize see **page N28**.*

LEE PART NUMBER	LOHM RATE	NOMINAL PASSAGE SIZE (Inches)	NOMINAL SCREEN HOLE SIZE (Inches)
VXCA2501480D	4 800	0.035	0.015
VXCA2501620D	6 200	0.030	0.015
VXCA2501740D	7 400	0.025	0.015
VXCA2501840D	8 400	0.025	0.015
VXCA2501980D	9 800	0.020	0.015
VXCA2501110H	11 000	0.020	0.015

B

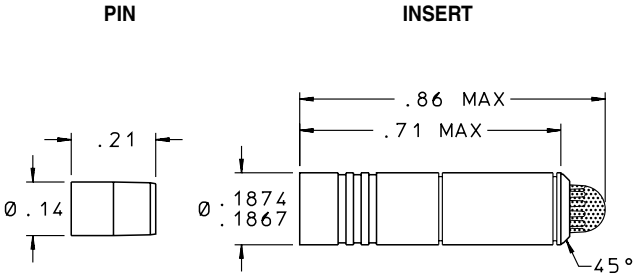

MATERIALS		
PART	MATERIAL	SPECIFICATION
Body	304L Cres	AMS QQ-S-763
Pin	17-4PH Cres	AMS 5643
JEVA Stack	304L Cres	ASTM A 666
Screens	304L Cres	ASTM A 666
Base Washer	304L Cres	ASTM A 666
Braze	—	AMS 4774

*Finish: All Cres Parts Passivated.  
Pins are prewaxed. Do not degrease. Do not lubricate.*

PERFORMANCE
Lohm Rate Tolerance ..... ±5% or ±10%
Maximum Working Pressure ..... 3000 psid
Nominal Weight..... 1.7 grams

*Note: See pages B44 – B45 for a complete list of Lohm rates and part numbers.*

## INSTALLATION HOLE

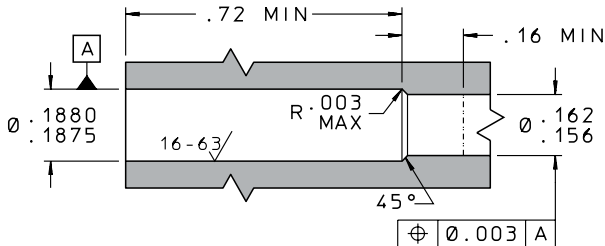

**B**

## INSTALLATION AND EXTRACTION

Tool Set Part Number ..... CUTA1870104C

Procedures ..... See **Pages N26 – N30**

Line Mount Configurations..... See **Pages L6 – L8**

Replacement Pin Part Number..... JEVA1870003B

*For boss size see **page N24**. For oversize see **page N28**.*

DISC INFORMATION		NOMINAL SCREEN DATA		
DISC STYLE	MINIMUM PASSAGE (Inches)	TOTAL AREA (Square Inches)	OPEN AREA (Square Inches)	SCREEN HOLE SIZE (Inches)
JEVA181	0.006	0.062	0.019	0.004
JEVA182	0.009	0.062	0.020	0.006
JEVA183	0.013	0.062	0.014	0.008
JEVA184	0.019	0.062	0.026	0.015
JEVA185	0.026	0.062	0.026	0.015

LEE PART NUMBER		LOHM RATE	MINIMUM PASSAGE SIZE (Inches)
±5%	±10%		
JEVA1855352D	JEVA1850352D	3 520	0.026
JEVA1855370D	JEVA1850370D	3 700	0.026
JEVA1855389D	JEVA1850389D	3 890	0.026
JEVA1855408D	JEVA1850408D	4 080	0.026
JEVA1855428D	JEVA1850428D	4 280	0.026
JEVA1855450D	JEVA1850450D	4 500	0.026
JEVA1855472D	JEVA1850472D	4 720	0.026
JEVA1855496D	JEVA1850496D	4 960	0.026
JEVA1855521D	JEVA1850521D	5 210	0.026
JEVA1855547D	JEVA1850547D	5 470	0.026
JEVA1855574D	JEVA1850574D	5 740	0.026
JEVA1855603D	JEVA1850603D	6 030	0.026
JEVA1855633D	JEVA1850633D	6 330	0.026
JEVA1855665D	JEVA1850665D	6 650	0.026
JEVA1855698D	JEVA1850698D	6 980	0.026
JEVA1855733D	JEVA1850733D	7 330	0.026
JEVA1845769D	JEVA1840769D	7 690	0.019
JEVA1845808D	JEVA1840808D	8 080	0.019
JEVA1845848D	JEVA1840848D	8 480	0.019
JEVA1845890D	JEVA1840890D	8 900	0.019
JEVA1845935D	JEVA1840935D	9 350	0.019
JEVA1845982D	JEVA1840982D	9 820	0.019
JEVA1845103H	JEVA1840103H	10 300	0.019
JEVA1845108H	JEVA1840108H	10 800	0.019
JEVA1845114H	JEVA1840114H	11 400	0.019
JEVA1845119H	JEVA1840119H	11 900	0.019
JEVA1845125H	JEVA1840125H	12 500	0.019
JEVA1845132H	JEVA1840132H	13 200	0.019
JEVA1845138H	JEVA1840138H	13 800	0.019
JEVA1845145H	JEVA1840145H	14 500	0.019
JEVA1845152H	JEVA1840152H	15 200	0.019
JEVA1845160H	JEVA1840160H	16 000	0.019
JEVA1845168H	JEVA1840168H	16 800	0.019
JEVA1845176H	JEVA1840176H	17 600	0.019
JEVA1835185H	JEVA1830185H	18 500	0.013
JEVA1835194H	JEVA1830194H	19 400	0.013
JEVA1835204H	JEVA1830204H	20 400	0.013
JEVA1835214H	JEVA1830214H	21 400	0.013
JEVA1835225H	JEVA1830225H	22 500	0.013
JEVA1835236H	JEVA1830236H	23 600	0.013
JEVA1835248H	JEVA1830248H	24 800	0.013
JEVA1835260H	JEVA1830260H	26 000	0.013
JEVA1835273H	JEVA1830273H	27 300	0.013
JEVA1835287H	JEVA1830287H	28 700	0.013
JEVA1835302H	JEVA1830302H	30 200	0.013
JEVA1835316H	JEVA1830316H	31 600	0.013
JEVA1835332H	JEVA1830332H	33 200	0.013

LEE PART NUMBER		LOHM RATE	MINIMUM PASSAGE SIZE (Inches)
±5%	±10%		
JEVA1835349H	JEVA1830349H	34 900	0.013
JEVA1835366H	JEVA1830366H	36 600	0.013
JEVA1835385H	JEVA1830385H	38 500	0.013
JEVA1835404H	JEVA1830404H	40 400	0.013
JEVA1835424H	JEVA1830424H	42 400	0.013
JEVA1835446H	JEVA1830446H	44 600	0.013
JEVA1835468H	JEVA1830468H	46 800	0.013
JEVA1825491H	JEVA1820491H	49 100	0.009
JEVA1825516H	JEVA1820516H	51 600	0.009
JEVA1825542H	JEVA1820542H	54 200	0.009
JEVA1825569H	JEVA1820569H	56 900	0.009
JEVA1825597H	JEVA1820597H	59 700	0.009
JEVA1825627H	JEVA1820627H	62 700	0.009
JEVA1825658H	JEVA1820658H	65 800	0.009
JEVA1825691H	JEVA1820691H	69 100	0.009
JEVA1825726H	JEVA1820726H	72 600	0.009
JEVA1825762H	JEVA1820762H	76 200	0.009
JEVA1825800H	JEVA1820800H	80 000	0.009
JEVA1825840H	JEVA1820840H	84 000	0.009
JEVA1825882H	JEVA1820882H	88 200	0.009
JEVA1825926H	JEVA1820926H	92 600	0.009
JEVA1825972H	JEVA1820972H	97 200	0.009
JEVA1825102K	JEVA1820102K	102 000	0.009
JEVA1825107K	JEVA1820107K	107 000	0.009
JEVA1825113K	JEVA1820113K	113 000	0.009
JEVA1825118K	JEVA1820118K	118 000	0.009
JEVA1825124K	JEVA1820124K	124 000	0.009
JEVA1825130K	JEVA1820130K	130 000	0.009
JEVA1815137K	JEVA1810137K	137 000	0.006
JEVA1815144K	JEVA1810144K	144 000	0.006
JEVA1815151K	JEVA1810151K	151 000	0.006
JEVA1815158K	JEVA1810158K	158 000	0.006
JEVA1815166K	JEVA1810166K	166 000	0.006
JEVA1815175K	JEVA1810175K	175 000	0.006
JEVA1815183K	JEVA1810183K	183 000	0.006
JEVA1815193K	JEVA1810193K	193 000	0.006
JEVA1815202K	JEVA1810202K	202 000	0.006
JEVA1815212K	JEVA1810212K	212 000	0.006
JEVA1815223K	JEVA1810223K	223 000	0.006
JEVA1815234K	JEVA1810234K	234 000	0.006
JEVA1815246K	JEVA1810246K	246 000	0.006
JEVA1815258K	JEVA1810258K	258 000	0.006
JEVA1815271K	JEVA1810271K	271 000	0.006
JEVA1815284K	JEVA1810284K	284 000	0.006
JEVA1815299K	JEVA1810299K	299 000	0.006
JEVA1815313K	JEVA1810313K	313 000	0.006

B

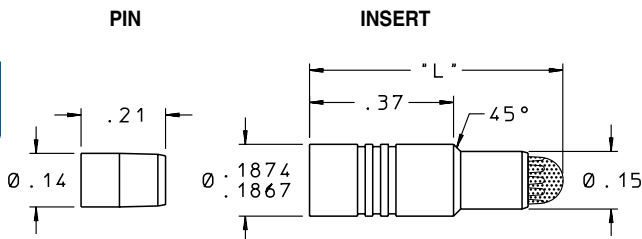

### MATERIALS

PART	MATERIAL	SPECIFICATION
Body	303 Cres	QQ-S-763C
Pin	303 Cres	QQ-S-763C
Internal Pin & Plug	303 Cres	QQ-S-763C
Spacer	303 Cres	QQ-S-763C
Visco Stack	304L Cres	ASTM A 666
Screens	304L Cres	ASTM A 666
Base Washer	304L Cres	ASTM A 666
Braze	—	AMS 477

*Finish: All Cres Parts Passivated.*

*Pins are prewaxed. Do not degrease. Do not lubricate.*

### PERFORMANCE

Lohm Rate Tolerance .....  $\pm 5\%$  or  $\pm 10\%$

Maximum Working Pressure ..... 3000 psid

Nominal Weight..... 1.4 grams

### DISC INFORMATION

### NOMINAL SCREEN DATA

DISC STYLE	MINIMUM PASSAGE SIZE (Inches)	TOTAL AREA (Square Inches)	OPEN AREA (Square Inches)	SCREEN HOLE SIZE (Inches)
VDCA181	0.005	0.062	0.019	0.004
VDCA182	0.007	0.062	0.019	0.004
VDCA183	0.010	0.062	0.020	0.006
VDCA184	0.015	0.062	0.014	0.008

### INSTALLATION HOLE

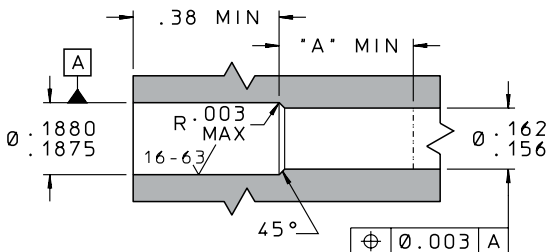

### INSTALLATION AND EXTRACTION

Tool Set Part Number ..... CUTA1870104C  
 Procedures ..... See [Pages N26 – N30](#)  
 Line Mount Configurations..... See [Pages L6 – L8](#)  
 Replacement Pin Part Number..... JETA1870003A  
 Master Set Part Number..... VDCA1871000A  
 Master Set Description ..... See [Pages B13 – B14](#)  
*For boss size see [page N24](#). For oversize see [page N28](#).*

LEE PART NUMBER		LOHM RATE	MINIMUM PASSAGE SIZE (In.)	"L" DIM. (In.)	MIN. "A" DIM. (In.)
±5%	±10%				
VDCA1845112H	VDCA1840112H	11 200	0.015	0.66	0.30
VDCA1845162H	VDCA1840162H	16 200	0.015	0.72	0.40
VDCA1835176H	VDCA1830176H	17 600	0.010	0.66	0.30
VDCA1835240H	VDCA1830240H	24 000	0.010	0.66	0.30
VDCA1835330H	VDCA1830330H	33 000	0.010	0.72	0.40
VDCA1835410H	VDCA1830410H	41 000	0.010	0.72	0.40
VDCA1825800H	VDCA1820800H	80 000	0.007	0.66	0.30
VDCA1815145K	VDCA1810145K	145 000	0.005	0.66	0.30
VDCA1815198K	VDCA1810198K	198 000	0.005	0.66	0.30
VDCA1815243K	VDCA1810243K	243 000	0.005	0.72	0.40
VDCA1815280K	VDCA1810280K	280 000	0.005	0.72	0.40
VDCA1815313K	VDCA1810313K	313 000	0.005	0.72	0.40

B

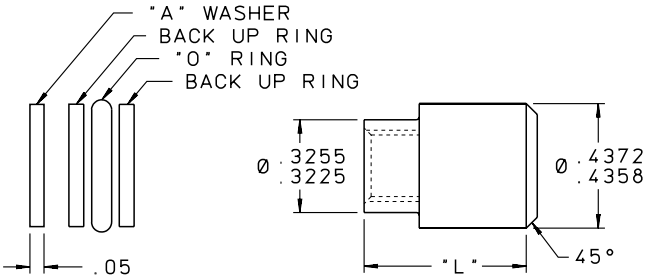

MATERIALS		
PART	MATERIAL	SPECIFICATION
Body	303 Cres	QQ-S-763C
Visco Stack	304L Cres	ASTM A 666
Screens	304L Cres	ASTM A 666
	304L Cres	ASTM A580 / 580M
Braze	—	AWS A5.8BNi-6
Screen Spacers	303 Cres	QQ-S-763C
	410 Cres	AMS QQ-S-763 & AMS 5613
End Washer	303 Cres	QQ-S-763C
Shims	304L Cres	ASTM A 666 & AMS 5647
"A" Washer	303 Cres	QQ-S-763C
Back Up Rings	Customer Supplied	(MS28774-011)
"O" Ring	Customer Supplied	(M83248/2-011)

Finish: All Cres Parts Passivated.

PERFORMANCE
Lohm Rate Tolerance..... ±5% or ±10%
Maximum Working Pressure..... 3000 psid
Nominal Weight..... 5.8 - 7.7 grams

DISC INFORMATION		NOMINAL SCREEN DATA		
DISC STYLE	MINIMUM PASSAGE SIZE (Inches)	TOTAL AREA (Square In.)	OPEN AREA (Square In.)	SCREEN HOLE SIZE (Inches)
VDCA431	0.005	0.043	0.010	0.001
VDCA432	0.015	0.070	0.014	0.010
VDCA433	0.031	0.070	0.025	0.020

INSTALLATION HOLE

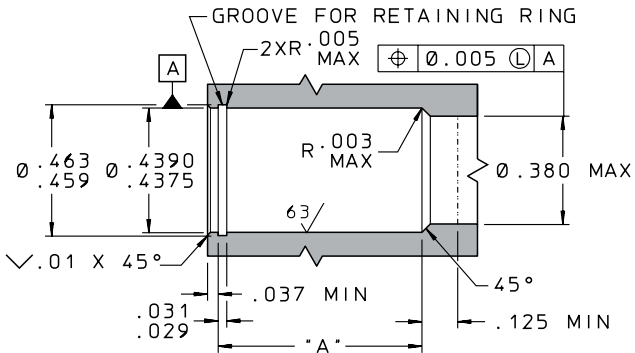

B

INSTALLATION AND EXTRACTION

- Procedures ..... See [Page N33](#)
- Instructions for High and Low Temperature ..... See [Pages N34 – N36](#)
- Line Mount Configurations ..... See [Page L15](#)

LEE PART NUMBER		LOHM RATE	MINIMUM PASSAGE SIZE (In.)	"L" DIM. (In.)	"A" DEPTH REAM ± 0.002"
±5%	±10%				
VDCA4335500D	VDCA4330500D	5 000	0.031	0.569	0.654
VDCA4335700D	VDCA4330700D	7 000	0.031	0.630	0.715
VDCA4325250H	VDCA4320250H	25 000	0.015	0.434	0.519
VDCA4325326H	VDCA4320326H	32 600	0.015	0.434	0.519
VDCA4325460H	VDCA4320460H	46 000	0.015	0.434	0.519
VDCA4325565H	VDCA4320565H	56 500	0.015	0.569	0.654
VDCA4325650H	VDCA4320650H	65 000	0.015	0.569	0.654
VDCA4325730H	VDCA4320730H	73 000	0.015	0.569	0.654
VDCA4315950K	VDCA4310950K	950 000	0.005	0.434	0.519
VDCA4315135T	VDCA4310135T	1350 000	0.005	0.569	0.654
VDCA4315220T	VDCA4310220T	2200 000	0.005	0.569	0.654

B

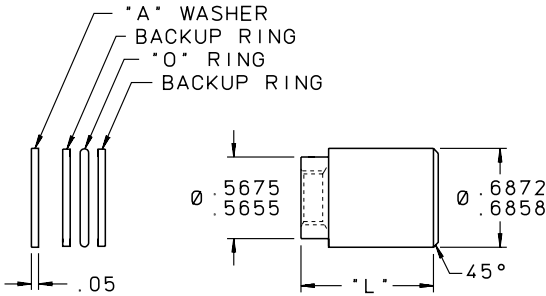

MATERIALS		
PART	MATERIAL	SPECIFICATION
Body	303 Cres	QQ-S-763C
Visco Stack	304L Cres	ASTM A 666
Screens	304L Cres	ASTM A 666
Spacers	303 Cres	QQ-S-763C
End Washer	303 Cres	QQ-S-763C
Shims	304L Cres	ASTM A 666
"A" Washer	303 Cres	QQ-S-763C
Back Up Rings	Customer Supplied	(MS28774-015)
"O" Ring	Customer Supplied	(M83248/2-015)

Finish: All Cres Parts Passivated.

PERFORMANCE	
Lohm Rate Tolerance.....	±5% or ±10%
Maximum Working Pressure.....	3000 psid
Nominal Weight .....	24.7 - 35.8 grams

DISC INFORMATION		NOMINAL SCREEN DATA		
DISC STYLE	MINIMUM PASSAGE SIZE (Inches)	TOTAL AREA (Square Inches)	OPEN AREA (Square Inches)	SCREEN HOLE SIZE (Inches)
VDC681	0.032	0.208	0.079	0.020
VDC682	0.062	No Screens	No Screens	No Screens

## INSTALLATION HOLE

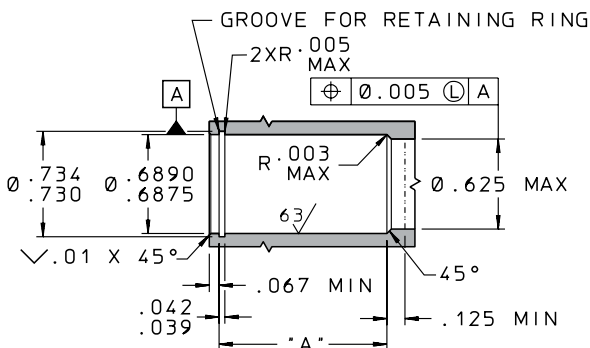

## INSTALLATION AND EXTRACTION

- Procedures ..... See [Page N33](#)
- Instructions for High and  
Low Temperature ..... See [Pages N34 – N36](#)
- Line Mount Configurations..... See [Page L16](#)

LEE PART NUMBER		LOHM RATE	MINIMUM PASSAGE SIZE (In.)	“L” DIM. (In.)	“A” DEPTH REAM ± 0.002”
±5%	±10%				
VDCA6825137D	VDCA6820137D	1370	0.062	0.702	0.797
VDCA6825181D	VDCA6820181D	1810	0.062	0.920	1.015
VDCA6815880D	VDCA6810880D	8800	0.032	0.702	0.797
VDCA6815124H	VDCA6810124H	12400	0.032	0.702	0.797
VDCA6815152H	VDCA6810152H	15200	0.032	0.920	1.015
VDCA6815176H	VDCA6810176H	17600	0.032	0.920	1.015
VDCA6815196H	VDCA6810196H	19600	0.032	1.029	1.124

B

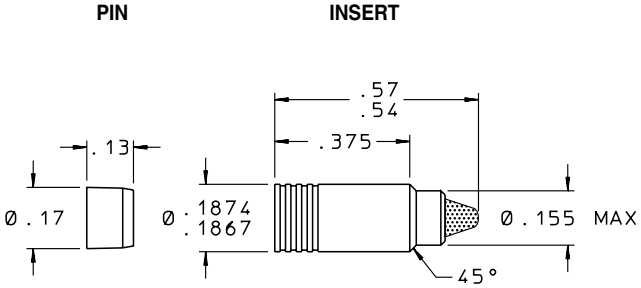

MATERIALS		
PART	MATERIAL	SPECIFICATION
Body	304L Cres	AMS QQ-S-763
Pin	15-5PH Cres	AMS 5659
Screen	15-5PH Cres	AMS 5659 or 5862

*Finish: All Cres Parts Passivated.*

*Pins are prewaxed. Do not degrease. Do not lubricate.*

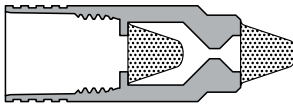

*Note: See [pages B54 – B55](#) for a complete list of Lohm rates and part numbers.*

## INSTALLATION HOLE

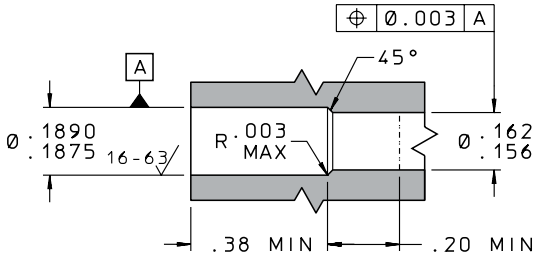

B

## INSTALLATION AND EXTRACTION

Tool Set Part Number ..... CUTA1870904C  
 Procedures ..... See [Pages N26 – N30](#)  
 Line Mount Configurations..... See [Pages L8, L20 – L31](#)  
 Replacement Pin Part Number..... JHTA1870003A

*For boss size see [page N24](#). For oversize see [page N28](#).*

## PERFORMANCE

Lohm Rate Tolerance .....  $\pm 2\%$  or  $\pm 5\%$   
 Maximum Working Pressure ..... 5000 psid  
 Nominal Weight..... 1.1 grams

B

LEE PART NUMBER		LOHM RATE	NOMINAL SCREEN HOLE SIZE (Inches)
±2%	±5%		
JHTA1872100D	JHTA1875100D	1 000	0.008
JHTA1872110D	JHTA1875110D	1 100	0.008
JHTA1872120D	JHTA1875120D	1 200	0.008
JHTA1872130D	JHTA1875130D	1 300	0.008
JHTA1872140D	JHTA1875140D	1 400	0.008
JHTA1872150D	JHTA1875150D	1 500	0.008
JHTA1872160D	JHTA1875160D	1 600	0.008
JHTA1872170D	JHTA1875170D	1 700	0.008
JHTA1872180D	JHTA1875180D	1 800	0.008
JHTA1872190D	JHTA1875190D	1 900	0.008
JHTA1872200D	JHTA1875200D	2 000	0.008
JHTA1872220D	JHTA1875220D	2 200	0.008
JHTA1872240D	JHTA1875240D	2 400	0.008
JHTA1872260D	JHTA1875260D	2 600	0.008
JHTA1872280D	JHTA1875280D	2 800	0.008
JHTA1872300D	JHTA1875300D	3 000	0.008
JHTA1872320D	JHTA1875320D	3 200	0.008
JHTA1872340D	JHTA1875340D	3 400	0.008
JHTA1872360D	JHTA1875360D	3 600	0.008
JHTA1872380D	JHTA1875380D	3 800	0.008
JHTA1872400D	JHTA1875400D	4 000	0.008
JHTA1872430D	JHTA1875430D	4 300	0.008

LEE PART NUMBER		LOHM RATE	NOMINAL SCREEN HOLE SIZE (Inches)
±2%	±5%		
JHTA1872460D	JHTA1875460D	4600	0.008
JHTA1872500D	JHTA1875500D	5000	0.008
JHTA1872550D	JHTA1875550D	5500	0.006
JHTA1872600D	JHTA1875600D	6000	0.006
JHTA1872650D	JHTA1875650D	6500	0.006
JHTA1872700D	JHTA1875700D	7000	0.006
JHTA1872750D	JHTA1875750D	7500	0.006
JHTA1872800D	JHTA1875800D	8000	0.006
JHTA1872850D	JHTA1875850D	8500	0.006
JHTA1872900D	JHTA1875900D	9000	0.006
JHTA1872950D	JHTA1875950D	9500	0.006
JHTA1872100H	JHTA1875100H	10000	0.006
JHTA1872110H	JHTA1875110H	11000	0.004
JHTA1872120H	JHTA1875120H	12000	0.004
JHTA1872130H	JHTA1875130H	13000	0.004
JHTA1872140H	JHTA1875140H	14000	0.004
JHTA1872150H	JHTA1875150H	15000	0.004
JHTA1872160H	JHTA1875160H	16000	0.004
JHTA1872170H	JHTA1875170H	17000	0.004
JHTA1872180H	JHTA1875180H	18000	0.004
JHTA1872190H	JHTA1875190H	19000	0.004
JHTA1872200H	JHTA1875200H	20000	0.004

PIN

INSERT

B

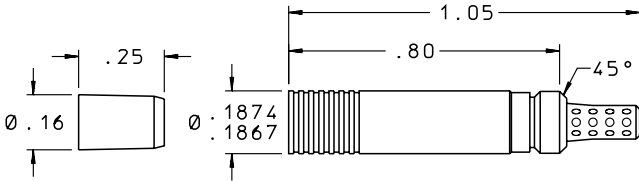

MATERIALS		
PART	MATERIAL	SPECIFICATION
Body	304L Cres	AMS QQ-S-763
Pin	17-4PH Cres	AMS 5643
Screens	440C Cres	AMS QQ-S-763
Metering Element	304L Cres	AMS QQ-S-763

*Finish: All Cres Parts Passivated.*

*Pins are prewaxed. Do not degrease. Do not lubricate.*

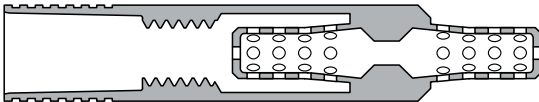

*Note: See [pages B58 – B59](#) for a complete list of Lohm rates and part numbers.*

## INSTALLATION HOLE

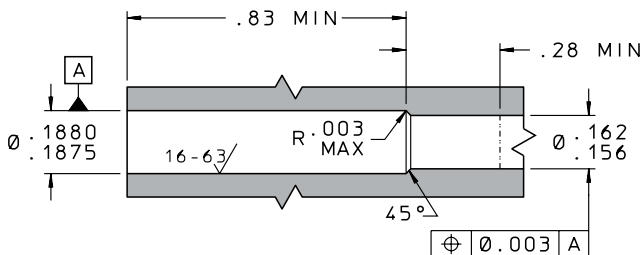

# B

## INSTALLATION AND EXTRACTION

- Tool Set Part Number ..... CUTA1870210C
- Procedures ..... See [Pages N26 – N30](#)
- Line Mount Configurations..... See [Pages L8, L20 – L31](#)
- Replacement Pin Part Number..... JHHA1870003A

*For boss size see [page N24](#). For oversize see [page N28](#).*

## PERFORMANCE

- Lohm Rate Tolerance .....  $\pm 2\%$  or  $\pm 5\%$
- Maximum Working Pressure ..... 8000 psid intermittent  
5000 psid continuous
- Nominal Weight..... 2.0 grams

B

LEE PART NUMBER	LOHM RATE	NOMINAL SCREEN HOLE SIZE (Inches)
±2%		
JHHA1872350L	350	0.024
JHHA1872375L	375	
JHHA1872400L	400	
JHHA1872425L	425	
JHHA1872450L	450	
JHHA1872475L	475	
JHHA1872500L	500	
JHHA1872550L	550	0.020
JHHA1872600L	600	
JHHA1872650L	650	
JHHA1872700L	700	
JHHA1872750L	750	
JHHA1872800L	800	0.015
JHHA1872850L	850	
JHHA1872900L	900	
JHHA1872950L	950	
JHHA1872100D	1000	
JHHA1872110D	1100	0.012
JHHA1872120D	1200	
JHHA1872130D	1300	
JHHA1872140D	1400	
JHHA1872150D	1500	
JHHA1872160D	1600	
JHHA1872170D	1700	
JHHA1872180D	1800	
JHHA1872190D	1900	
JHHA1872200D	2000	
JHHA1872220D	2200	0.008
JHHA1872240D	2400	
JHHA1872260D	2600	
JHHA1872280D	2800	
JHHA1872300D	3000	

LEE PART NUMBER	LOHM RATE	NOMINAL SCREEN HOLE SIZE (Inches)
±5%		
JHHA1875350L	350	0.024
JHHA1875375L	375	
JHHA1875400L	400	
JHHA1875425L	425	
JHHA1875450L	450	
JHHA1875475L	475	
JHHA1875500L	500	0.020
JHHA1875550L	550	
JHHA1875600L	600	
JHHA1875650L	650	
JHHA1875700L	700	
JHHA1875750L	750	
JHHA1875800L	800	0.015
JHHA1875850L	850	
JHHA1875900L	900	
JHHA1875950L	950	
JHHA1875100D	1000	
JHHA1875110D	1100	
JHHA1875120D	1200	
JHHA1875130D	1300	
JHHA1875140D	1400	
JHHA1875150D	1500	
JHHA1875160D	1600	
JHHA1875170D	1700	
JHHA1875180D	1800	
JHHA1875190D	1900	
JHHA1875200D	2000	
JHHA1875220D	2200	0.008
JHHA1875240D	2400	
JHHA1875260D	2600	
JHHA1875280D	2800	
JHHA1875300D	3000	

B

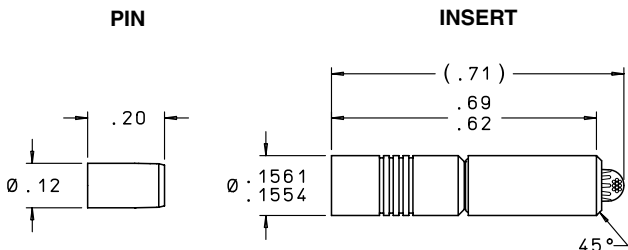

MATERIALS		
PART	MATERIAL	SPECIFICATION
Body	304L Cres	AMS 5647
Pin	15-5PH Cres	AMS 5659
Metering Discs	17-7PH Cres	AMS 5529
Spacers	303 Cres	QQ-S-763C
Screens	304L Cres	ASTM A 666
Braze	—	AMS 4774

*Finish: All Cres Parts Passivated.*

*Pins are prewaxed. Do not degrease. Do not lubricate.*

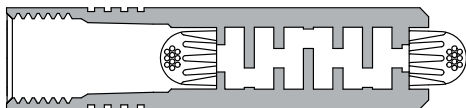

### PERFORMANCE

Lohm Rate Tolerance.....	±5%
Maximum Working Pressure.....	5000 psid
Nominal Weight .....	1.1 grams

### INSTALLATION HOLE

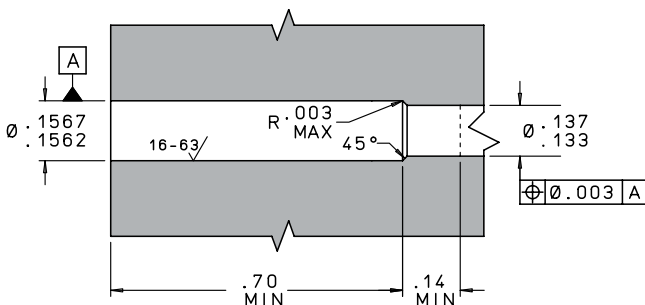

**B**

### INSTALLATION AND EXTRACTION

Tool Set Part Number ..... CUTA1560104C

Procedures ..... See **Pages N26 – N30**

Replacement Pin Part Number ..... JETA1560003A

*For boss size see **page N24**. For oversize see **page N28**.*

LEE PART NUMBER	LOHM RATE ±5%	MINIMUM PASSAGE SIZE (Inches)	NOMINAL SCREEN HOLE SIZE (Inches)
JHBA1565190D	1900	0.029	0.008
JHBA1565240D	2400	0.024	0.008
JHBA1565330D	3300	0.024	0.008
JHBA1565370D	3700	0.019	0.008
JHBA1565500D	5000	0.019	0.008
JHBA1565590D	5900	0.017	0.008
JHBA1565710D	7100	0.014	0.008
JHBA1565950D	9500	0.014	0.008

B

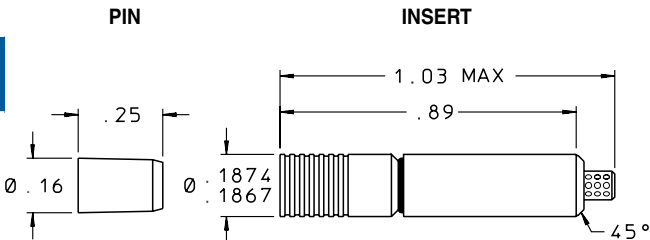

MATERIALS		
PART	MATERIAL	SPECIFICATION
Body	304L Cres	AMS 5647
Pin	17-4PH Cres	AMS 5643
Retainer	17-4PH Cres	AMS 5643
Spacers	303 Cres	QQ-S-763C
Metering Discs	17-7PH Cres	AMS 5529
Drilled Screens	303 Cres	QQ-S-763C
Etched Screens	304L Cres	ASTM A 666
Base Washer	304L Cres	ASTM A 666
Braze	—	AMS 4774

*Finish: All Cres Parts Passivated.*

*Pins are prewaxed. Do not degrease. Do not lubricate.*

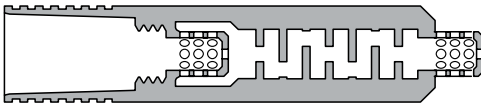

### PERFORMANCE

Lohm Rate Tolerance.....	±5%
Maximum Working Pressure.....	8000 psid
Nominal Weight.....	2.0 grams

### INSTALLATION HOLE

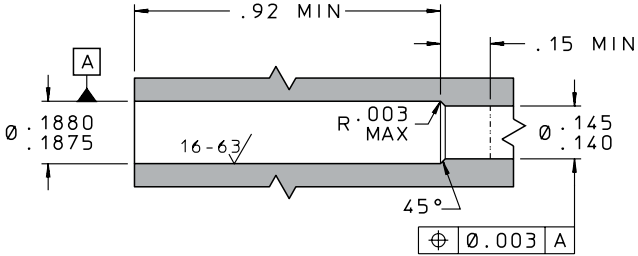

### INSTALLATION AND EXTRACTION

Tool Set Part Number ..... CUTA1870109C  
 Procedures ..... See **Pages N26 – N30**  
 Line Mount Configurations ..... See **Pages L8, L20 – L31**  
 Replacement Pin Part Number..... JHHA1870003A

*For boss size see **page N24**. For oversize see **page N28**.*

LEE PART NUMBER	LOHM RATE $\pm 5\%$	MINIMUM PASSAGE SIZE (Inches)	NOMINAL SCREEN HOLE SIZE (Inches)
JHBA1875190D	1900	0.030	0.020
JHBA1875240D	2400	0.030	0.020
JHBA1875330D	3300	0.025	0.015
JHBA1875370D	3700	0.020	0.015
JHBA1875500D	5000	0.020	0.015
JHBA1875590D	5900	0.020	0.015
JHBA1875710D	7100	0.015	0.008
JHBA1875950D	9500	0.015	0.008

B

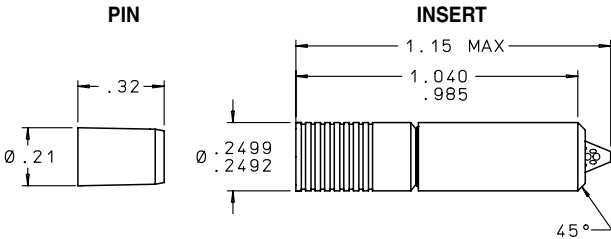

MATERIALS		
PART	MATERIAL	SPECIFICATION
Locking End	304 Cres	AMS 5639
Pin	17-4PH Cres	AMS 5643
Metering Element	15-5PH Cres	AMS 5659
Body	15-5PH Cres	AMS 5659
Screen	304L Cres	AMS 5647

*Finish: All Cres Parts Passivated.  
Pins are prewaxed. Do not degrease. Do not lubricate.*

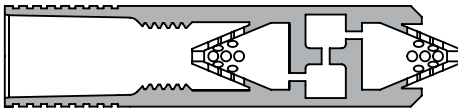

PERFORMANCE	
Lohm Rate Tolerance .....	±5%
Maximum Working Pressure .....	5000 psid
Nominal Weight.....	4.0 grams

## INSTALLATION HOLE

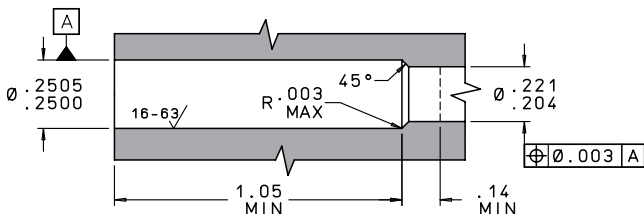

**B**

## INSTALLATION AND EXTRACTION

Tool Set Part Number ..... CUTA2500406C

Procedures ..... See [Pages N26 – N30](#)

Replacement Pin Part Number ..... CHFA2500003A

*For boss size see [page N24](#). For oversize see [page N28](#).*

LEE PART NUMBER	LOHM RATE ±5%	MINIMUM PASSAGE SIZE (Inches)	NOMINAL SCREEN HOLE SIZE (Inches)
JHBA2505600L	600	.050	.024
JHBA2505650L	650	.048	.024
JHBA2505700L	700	.046	.024
JHBA2505750L	750	.044	.024
JHBA2505800L	800	.042	.020
JHBA2505850L	850	.040	.020
JHBA2505900L	900	.039	.020
JHBA2505950L	950	.037	.020
JHBA2505100D	1000	.036	.020
JHBA2505110D	1100	.035	.015
JHBA2505120D	1200	.033	.015
JHBA2505130D	1300	.032	.015
JHBA2505140D	1400	.031	.015
JHBA2505150D	1500	.030	.015
JHBA2505160D	1600	.029	.015
JHBA2505170D	1700	.027	.015
JHBA2505180D	1800	.026	.015

B

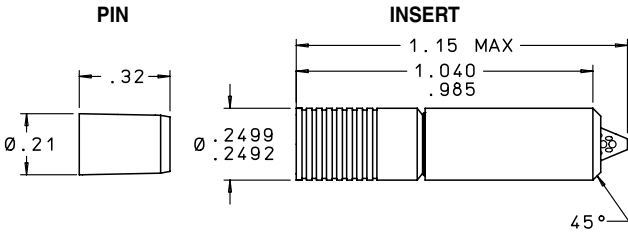

MATERIALS	
PART	MATERIAL
Locking End	MP35N
Pin	MP35N
Metering Element	MP35N
Body	MP35N
Screen	MP35N

*Pins are prewaxed. Do not degrease. Do not lubricate.*

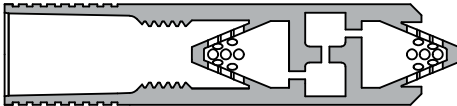

PERFORMANCE	
Lohm Rate Tolerance.....	±5%
Maximum Working Pressure .....	5000 psid
Nominal Weight.....	4.5 grams

## INSTALLATION HOLE

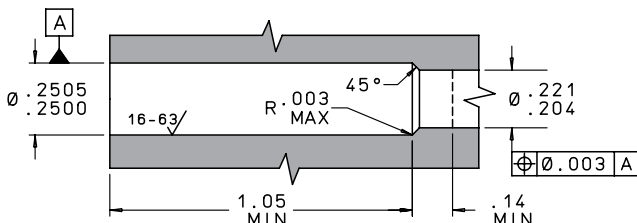

**B**

## INSTALLATION AND EXTRACTION

Tool Set Part Number ..... CUTA2500406C  
 Procedures ..... See **Pages N26 – N30**  
 Replacement Pin Part Number ..... JHBA2501010B

*For boss size see **page N24**. For oversize see **page N28**.*

LEE PART NUMBER	LOHM RATE ±5%	MINIMUM PASSAGE SIZE (Inches)	NOMINAL SCREEN HOLE SIZE (Inches)
JHBA2501600L	600	.050	.024
JHBA2501650L	650	.048	.024
JHBA2501700L	700	.046	.024
JHBA2501750L	750	.044	.024
JHBA2501800L	800	.042	.020
JHBA2501850L	850	.040	.020
JHBA2501900L	900	.039	.020
JHBA2501950L	950	.037	.020
JHBA2501100D	1000	.036	.020
JHBA2501110D	1100	.035	.015
JHBA2501120D	1200	.033	.015
JHBA2501130D	1300	.032	.015
JHBA2501140D	1400	.031	.015
JHBA2501150D	1500	.030	.015
JHBA2501160D	1600	.029	.015
JHBA2501170D	1700	.027	.015
JHBA2501180D	1800	.026	.015

B

PIN

INSERT

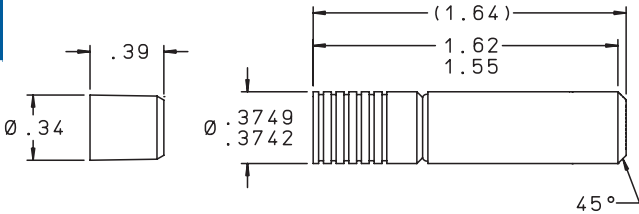

MATERIALS		
PART	MATERIAL	SPECIFICATION
Body	304L Cres	AMS 5647
Pin	17-4PH Cres	AMS 5643
Metering Element	15-5PH Cres	AMS 5659
Spacers	15-5PH Cres	AMS 5659

*Finish: All Cres Parts Passivated.  
Pins are prewaxed. Do not degrease. Do not lubricate.*

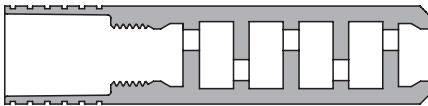

PERFORMANCE	
Lohm Rate Tolerance .....	±5%
Maximum Working Pressure.....	5000 psid
Nominal Weight .....	12 grams

## INSTALLATION HOLE

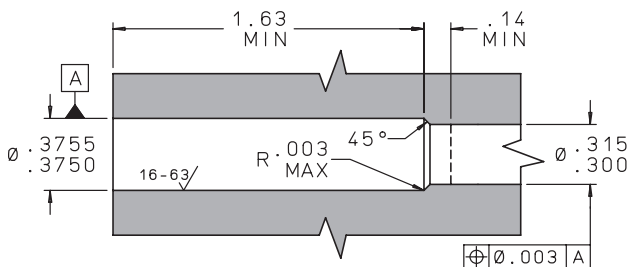

# B

## INSTALLATION AND EXTRACTION

Tool Set Part Number ..... CUTA3750306C

Procedures ..... See Pages N26 – N30

Replacement Pin Part Number ..... PHRA3750003A

*For boss size see page N24. For oversize see page N28.*

LEE PART NUMBER	LOHM RATE $\pm 5\%$	MINIMUM PASSAGE SIZE (Inches)
JHBA3755125L	125	.124
JHBA3755175L	175	.103
JHBA3755225L	225	.091
JHBA3755275L	275	.081
JHBA3755325L	325	.074
JHBA3755375L	375	.070

B

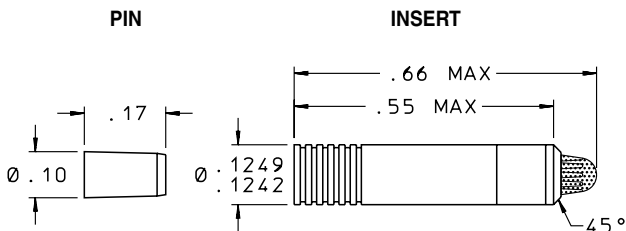
**MATERIALS**

PART	MATERIAL	SPECIFICATION
Body	304L Cres	AMS QQ-S-763
Pin	17-4PH Cres	AMS 5643
Visco Stack	304L Cres	ASTM A 666
Screens	304L Cres	ASTM A 666
Base Washer	304L Cres	ASTM A 666
Braze	—	AMS 4774 and AWS A5.8 BNi-6

*Finish: All Cres Parts Passivated.*

*Pins are prewaxed. Do not degrease. Do not lubricate.*

**PERFORMANCE**

Lohm Rate Tolerance.....	±5% or ±10%
Maximum Working Pressure.....	8000 psid
Nominal Weight .....	1.0 gram

**DISC INFORMATION****NOMINAL SCREEN DATA**

DISC STYLE	MINIMUM PASSAGE SIZE (Inches)	TOTAL AREA (Square Inches)	OPEN AREA (Square Inches)	SCREEN HOLE SIZE (Inches)
VHCA121	0.005	0.028	0.009	0.004
VHCA122	0.007	0.028	0.009	0.004
VHCA123	0.010	0.028	0.010	0.006
VHCA124	0.015	0.028	0.007	0.006

### INSTALLATION HOLE

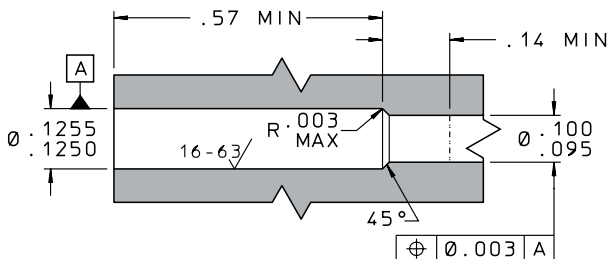

**B**

### INSTALLATION AND EXTRACTION

Tool Set Part Number ..... CUTA1250306C

Procedures ..... See **Pages N26 – N30**

*For boss size see **page N24**. For oversize see **page N28**.*

LEE PART NUMBER		LOHM RATE	MINIMUM PASSAGE SIZE (Inches)
±5%	±10%		
VHCA1245112H	VHCA1240112H	11 200	0.015
VHCA1245162H	VHCA1240162H	16 200	0.015
VHCA1235176H	VHCA1230176H	17 600	0.010
VHCA1235240H	VHCA1230240H	24 000	0.010
VHCA1235330H	VHCA1230330H	33 000	0.010
VHCA1235410H	VHCA1230410H	41 000	0.010
VHCA1225800H	VHCA1220800H	80 000	0.007
VHCA1215145K	VHCA1210145K	145 000	0.005
VHCA1215198K	VHCA1210198K	198 000	0.005
VHCA1215243K	VHCA1210243K	243 000	0.005
VHCA1215280K	VHCA1210280K	280 000	0.005
VHCA1215313K	VHCA1210313K	313 000	0.005

B

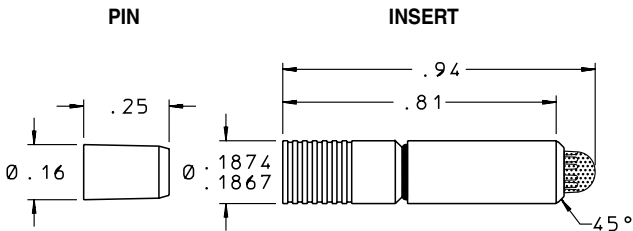

### MATERIALS

PART	MATERIAL	SPECIFICATION
Body	304L Cres	AMS QQ-S-763
Pin	17-4PH Cres	AMS 5643
Spacers	303 Cres	QQ-S-763C
Visco Stack	304L Cres	ASTM A 666
Retainer	17-4PH Cres	AMS 5643
Screens	304L Cres	ASTM A 666
Base Washer	304L Cres	ASTM A 666
Braze	—	AMS 4774

*Finish: All Cres Parts Passivated.*

*Pins are prewaxed. Do not degrease. Do not lubricate.*

### PERFORMANCE

Lohm Rate Tolerance .....	±5% or ±10%
Maximum Working Pressure.....	8000 psid
Nominal Weight.....	2.0 grams

### DISC INFORMATION

### NOMINAL SCREEN DATA

DISC STYLE	MINIMUM PASSAGE SIZE (Inches)	TOTAL AREA (Square Inches)	OPEN AREA (Square Inches)	SCREEN HOLE SIZE (Inches)
VHCA181	0.005	0.062	0.019	0.004
VHCA182	0.007	0.062	0.019	0.004
VHCA183	0.010	0.062	0.020	0.006
VHCA184	0.015	0.062	0.014	0.008

### INSTALLATION HOLE

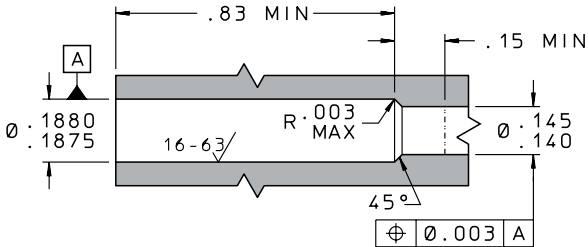

### INSTALLATION AND EXTRACTION

Tool Set Part Number ..... CUTA1870109C  
 Procedures ..... See [Pages N26 – N30](#)  
 Line Mount Configurations..... See [Pages L8, L20 – L31](#)  
 Replacement Pin Part Number..... JHHA1870003A

*For boss size see [page N24](#). For oversize see [page N28](#).*

LEE PART NUMBER		LOHM RATE	MINIMUM PASSAGE SIZE (Inches)
±5%	±10%		
VHCA1845112H	VHCA1840112H	11 200	0.015
VHCA1845162H	VHCA1840162H	16 200	0.015
VHCA1835176H	VHCA1830176H	17 600	0.010
VHCA1835240H	VHCA1830240H	24 000	0.010
VHCA1835330H	VHCA1830330H	33 000	0.010
VHCA1835410H	VHCA1830410H	41 000	0.010
VHCA1825800H	VHCA1820800H	80 000	0.007
VHCA1815145K	VHCA1810145K	145 000	0.005
VHCA1815198K	VHCA1810198K	198 000	0.005
VHCA1815243K	VHCA1810243K	243 000	0.005
VHCA1815280K	VHCA1810280K	280 000	0.005
VHCA1815313K	VHCA1810313K	313 000	0.005

B

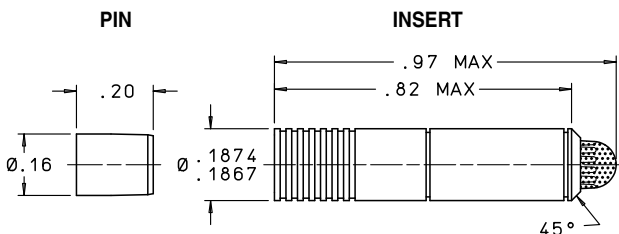

### MATERIALS

PART	MATERIAL	SPECIFICATION
Body	316L Cres	AMS 5653
Pin	MP35N	—
JEVA Stack	316L Cres	ASTM A 666
Screens	316L Cres	ASTM A 666
Braze	—	AMS 4774

*Finish: All Cres Parts Passivated.*

*Pins are prewaxed. Do not degrease. Do not lubricate.*

DISC INFORMATION		NOMINAL SCREEN DATA		
DISC STYLE	MINIMUM PASSAGE SIZE (Inches)	TOTAL AREA (Sq. Inches)	OPEN AREA (Sq. Inches)	SCREEN HOLE SIZE (Inches)
JHVA181	0.006	0.062	0.019	0.004
JHVA182	0.009	0.062	0.020	0.006
JHVA183	0.013	0.062	0.014	0.008
JHVA184	0.019	0.062	0.026	0.015
JHVA185	0.026	0.062	0.026	0.015

## INSTALLATION HOLE

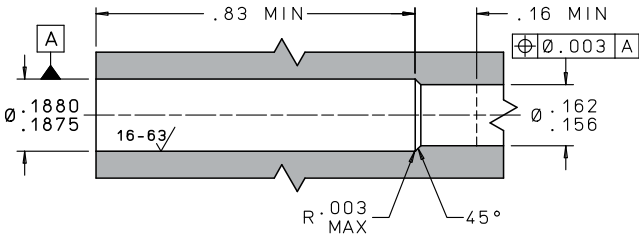

**B**

## INSTALLATION AND EXTRACTION

Tool Set Part Number ..... CUTA1877000C

Procedures ..... See [Pages N26 – N30](#)

*For boss size see [page N24](#). For oversize see [page N28](#).*

## PERFORMANCE

Lohm Rate Tolerance .....  $\pm 5\%$

Maximum Working Pressure ..... 5000 psid

Nominal Weight..... 1.8 grams

B

LEE PART NUMBER	LOHM RATE ±5%	MIN. PASSAGE SIZE (In.)	NOM. SCREEN HOLE SIZE (In.)
JHVA1855352D	3 520	.026	.015
JHVA1855370D	3 700	.026	.015
JHVA1855389D	3 890	.026	.015
JHVA1855408D	4 080	.026	.015
JHVA1855428D	4 280	.026	.015
JHVA1855450D	4 500	.026	.015
JHVA1855472D	4 720	.026	.015
JHVA1855496D	4 960	.026	.015
JHVA1855521D	5 210	.026	.015
JHVA1855547D	5 470	.026	.015
JHVA1855574D	5 740	.026	.015
JHVA1855603D	6 030	.026	.015
JHVA1855633D	6 330	.026	.015
JHVA1855665D	6 650	.026	.015
JHVA1855698D	6 980	.026	.015
JHVA1855733D	7 330	.026	.015
JHVA1845769D	7 690	.019	.015
JHVA1845808D	8 080	.019	.015
JHVA1845848D	8 480	.019	.015
JHVA1845890D	8 900	.019	.015
JHVA1845935D	9 350	.019	.015
JHVA1845982D	9 820	.019	.015
JHVA1845103H	10 300	.019	.015
JHVA1845108H	10 800	.019	.015
JHVA1845114H	11 400	.019	.015
JHVA1845119H	11 900	.019	.015
JHVA1845125H	12 500	.019	.015
JHVA1845132H	13 200	.019	.015
JHVA1845138H	13 800	.019	.015
JHVA1845145H	14 500	.019	.015
JHVA1845152H	15 200	.019	.015
JHVA1845160H	16 000	.019	.015
JHVA1845168H	16 800	.019	.015
JHVA1845176H	17 600	.019	.015
JHVA1835185H	18 500	.013	.008
JHVA1835194H	19 400	.013	.008
JHVA1835204H	20 400	.013	.008
JHVA1835214H	21 400	.013	.008
JHVA1835225H	22 500	.013	.008
JHVA1835236H	23 600	.013	.008
JHVA1835248H	24 800	.013	.008
JHVA1835260H	26 000	.013	.008
JHVA1835273H	27 300	.013	.008
JHVA1835287H	28 700	.013	.008
JHVA1835302H	30 200	.013	.008
JHVA1835316H	31 600	.013	.008
JHVA1835332H	33 200	.013	.008

LEE PART NUMBER	LOHM RATE ±5%	MIN. PASSAGE SIZE (In.)	NOM. SCREEN HOLE SIZE (In.)
JHVA1835349H	34 900	.013	.008
JHVA1835366H	36 600	.013	.008
JHVA1835385H	38 500	.013	.008
JHVA1835404H	40 400	.013	.008
JHVA1835424H	42 400	.013	.008
JHVA1835446H	44 600	.013	.008
JHVA1835468H	46 800	.013	.008
JHVA1825491H	49 100	.009	.006
JHVA1825516H	51 600	.009	.006
JHVA1825542H	54 200	.009	.006
JHVA1825569H	56 900	.009	.006
JHVA1825597H	59 700	.009	.006
JHVA1825627H	62 700	.009	.006
JHVA1825658H	65 800	.009	.006
JHVA1825691H	69 100	.009	.006
JHVA1825726H	72 600	.009	.006
JHVA1825762H	76 200	.009	.006
JHVA1825800H	80 000	.009	.006
JHVA1825840H	84 000	.009	.006
JHVA1825882H	88 200	.009	.006
JHVA1825926H	92 600	.009	.006
JHVA1825972H	97 200	.009	.006
JHVA1825102K	102 000	.009	.006
JHVA1825107K	107 000	.009	.006
JHVA1825113K	113 000	.009	.006
JHVA1825118K	118 000	.009	.006
JHVA1825124K	124 000	.009	.006
JHVA1825130K	130 000	.009	.006
JHVA1815137K	137 000	.006	.004
JHVA1815144K	144 000	.006	.004
JHVA1815151K	151 000	.006	.004
JHVA1815158K	158 000	.006	.004
JHVA1815166K	166 000	.006	.004
JHVA1815175K	175 000	.006	.004
JHVA1815183K	183 000	.006	.004
JHVA1815193K	193 000	.006	.004
JHVA1815202K	202 000	.006	.004
JHVA1815212K	212 000	.006	.004
JHVA1815223K	223 000	.006	.004
JHVA1815234K	234 000	.006	.004
JHVA1815246K	246 000	.006	.004
JHVA1815258K	258 000	.006	.004
JHVA1815271K	271 000	.006	.004
JHVA1815284K	284 000	.006	.004
JHVA1815299K	299 000	.006	.004
JHVA1815313K	313 000	.006	.004

# Flow Metering Valves

C





- Metered Flow in One Direction and No Flow in the Other
- Poppet Lifts to Wide Open Position with only 20 psid



- Choice of Four Sizes
- Wide Lohm Rate Selection
- High Pressure Models Available



- Constant Flow Regardless of  $\Delta P$
- Wide Range of Control

## TABLE OF CONTENTS

<b>Restrictor Cheks</b>	Metered flow in one direction, no flow in the other ..... 3, 6 – 7
<b>Directional Flow Controls</b>	Metered flow in one direction, free flow in the other (one-way restrictor)..... 4, 8 – 15
<b>High Pressure Flow Controls</b>	Directional flow controls for up to 8000 psid..... 16 – 25
<b>Floserts</b>	Pressure compensated flow control..... 5, 26 – 29
<b>High Pressure Floserts</b>	For system pressures up to 5000 psi ..... 30 – 35
<b>NACE Compliant Floserts</b>	For harsh duty applications with pressures up to 8000 psi ..... 36 – 40

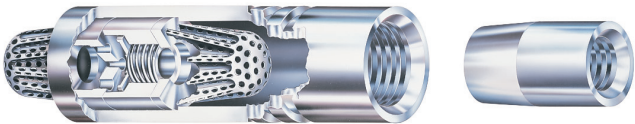

The Lee Company makes three different types of flow metering valves; a Restrictor Chek, a Directional Flow Control and a Flosert.

Lee Restrictor Cheks combine the function of a restrictor in series with a check valve into one miniature package.

Lee Directional Flow Controls provide metered flow in one direction and free flow in the opposite direction (this function is sometimes called a one-way restrictor).

The Lee Company has also designed dual metering flow controls that provide different metered flow rates for the forward and reverse flow directions. Consult your Lee Sales Engineer for more information.

Lee Floserts (pressure compensated flow control) provide a constant flow over a wide range of differential pressures.

## RESTRICTOR CHEK

Lee Restrictor Cheks are miniature inserts available in metered Lohm rates from 1000 – 10,000 Lohms, and are screened to protect the orifice. Flow through the orifice creates pressure drop across the ball which moves it completely away from the seat. This unique design eliminates silting problems which occur whenever a restrictor is used in series with a check valve. Lee Restrictor Cheks maintain large minimum passageways for reliable performance.

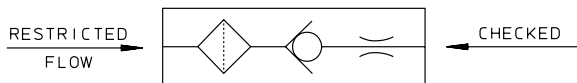

Lee Restrictor Cheks are used wherever a metered Lohm rate is needed in one direction and no flow in the other. They are often used in lines that flow during operation and trap fluid upstream upon shutdown.

### DIRECTIONAL FLOW CONTROLS

Lee Directional Flow Controls come in five different free flow Lohm rates to provide the designer with the optimum size insert. In addition, there are four sizes of High Pressure Directional Flow Controls. The Lee Directional Flow Control utilizes the full pressure drop across the restrictor to lift the moving element completely away from the seat in the free flow direction. Screens, when required provide further protection from contamination in both flow directions.

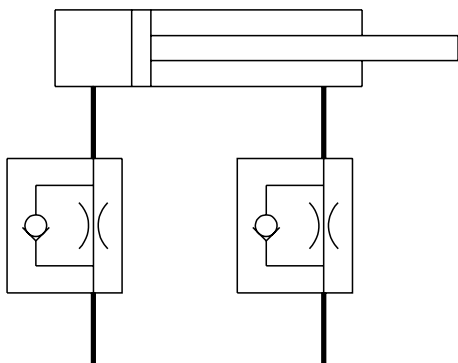

Directional Flow controls are ideal for timing applications where metering on the outlet in both flow directions is essential. As shown in the diagram above, the two flow controls maintain high back pressure when the actuator is moving in either direction, thus preventing cavitation.

### FLOSERTS

Lee Floserts are pressure compensated flow controls which provide a constant flow over a wide range of pressure drop across the insert.

The Flosert operates by sensing the flow rate in terms of a differential pressure across a fixed orifice.

A variable metering orifice automatically adjusts to keep this pressure, and hence the flow rate constant.

Ten flow rates from .01 to .10 GPM in 0.250 inch diameter body, thirteen flow rates from 0.1 to 1.0 GPM in a 0.281 inch diameter body, and eight flow rates from 1.5 to 5.0 GPM in a 0.500 inch diameter body are available. Also available are Floserts designed for the Oil Tool Industry that are constructed entirely of corrosion-resistant materials that comply with NACE specification MR0175/ISO 15156.

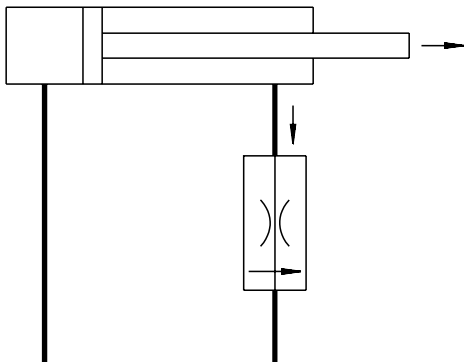

Floserts are useful for controlling the velocity of an actuator under varying loads. They can increase the stiffness of a hydrostatic bearing or limit the maximum flow rate to control the speed of a pump or motor. More than one Flosert will ratio flows or synchronize several jacks regardless of loads.

## 6

## Restrictor Chek

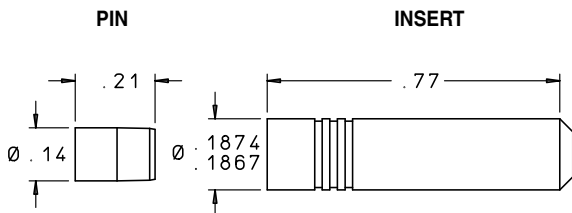

## MATERIALS

PART	MATERIAL	SPECIFICATION
Body	303 Cres	QQ-S-763C
Pin	303 Cres	QQ-S-763C
Cage	303 Cres	QQ-S-763C
Ball Follower	303 Cres	QQ-S-763C
Spring	17-7PH Cres	AMS 5678
Ball	440C Cres	AMS 5630
Screen	304L Cres	ASTM A 666
Braze	—	AMS 4774

*Finish: All CRES parts passivated.*

*Pins are prewaxed. Do not degrease. Do not lubricate.*

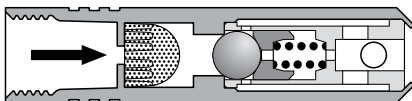

**RCFA1870100D • METERED FLOW FORWARD**

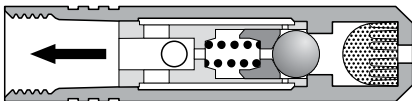

**RCRA1870100D • METERED FLOW REVERSE**

## PERFORMANCE

Metered Lohm Rate Tolerance .....	±5% or ±10%
Max. leakage in checked direction.....	1 drop/min. at 5 psid on MIL-PRF-83282 at 85°F. 1 drop = 50 µL 1 drop/hr. at 1000 - 3000 psid
Nominal System Pressure .....	up to 3000 psi
Cracking Pressure .....	2 - 8 psid
Nominal Weight .....	2.7 grams

## INSTALLATION HOLE

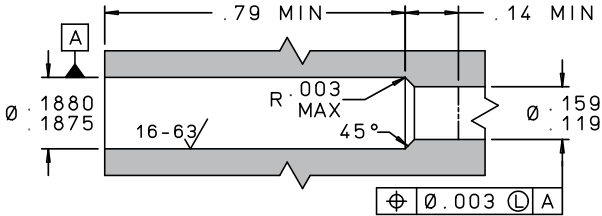

## INSTALLATION AND EXTRACTION

Part Number ..... CUTA1870104C  
 Installation/Extraction Procedures ..... See **Pages N26 – N30**  
 Line Mount Configurations..... See **Pages L6 – L8**  
 Replacement Pin Part Number..... JETA1870003A

*For boss size see **page N24**. For oversize see **page N28**.*

LEE PART NUMBER		METERED LOHM RATE	NOMINAL SCREEN HOLE SIZE (inches)
±5%	±10%		
<b>METERED FLOW FORWARD</b>			
RCFA1875100D	RCFA1870100D	1000	0.008
RCFA1875150D	RCFA1870150D	1500	0.008
RCFA1875200D	RCFA1870200D	2000	0.008
RCFA1875250D	RCFA1870250D	2500	0.008
RCFA1875300D	RCFA1870300D	3000	0.008
RCFA1875400D	RCFA1870400D	4000	0.006
RCFA1875500D	RCFA1870500D	5000	0.006
RCFA1875600D	RCFA1870600D	6000	0.006
RCFA1875800D	RCFA1870800D	8000	0.004
RCFA1875100H	RCFA1870100H	10000	0.004
<b>METERED FLOW REVERSE</b>			
RCRA1875100D	RCRA1870100D	1000	0.008
RCRA1875150D	RCRA1870150D	1500	0.008
RCRA1875200D	RCRA1870200D	2000	0.008
RCRA1875250D	RCRA1870250D	2500	0.008
RCRA1875300D	RCRA1870300D	3000	0.008
RCRA1875400D	RCRA1870400D	4000	0.006
RCRA1875500D	RCRA1870500D	5000	0.006
RCRA1875600D	RCRA1870600D	6000	0.006
RCRA1875800D	RCRA1870800D	8000	0.004
RCRA1875100H	RCRA1870100H	10000	0.004

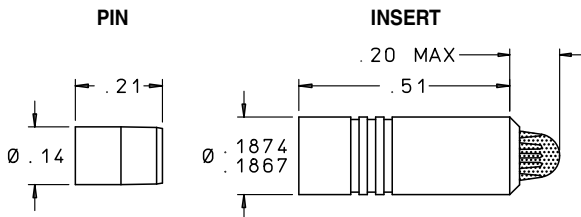

### MATERIALS

PART	MATERIAL	SPECIFICATION
Body	303 Cres	QQ-S-763C
Pin	303 Cres	QQ-S-763C
Spring Seat	303 Cres	QQ-S-763C
Orifice Plate	303 Cres	QQ-S-763C
Shuttle Plate	303 Cres	QQ-S-763C
Spring	302 Cres	AMS 5688
Screen	304L Cres	ASTM A 666
Braze	—	AMS 4774

*Finish: All CRES parts passivated.*

*Pins are prewaxed. Do not degrease. Do not lubricate.*

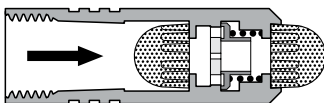

**FCFA1870100D • FREE FLOW FORWARD**

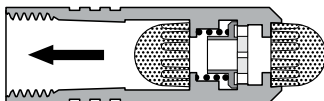

**FCFA1870100D • FREE FLOW REVERSE**

### PERFORMANCE

Metered Lohm Rate Tolerance.....	±5% or ±10%
Nominal System Pressure .....	up to 3000 psi
Cracking Pressure .....	2 - 8 psid
Free Flow Lohm Rate at ≥25 psid .....	470 Lohms maximum
Nominal Weight .....	1.3 grams

## INSTALLATION HOLE

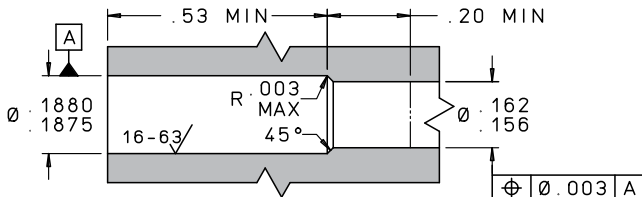

## INSTALLATION AND EXTRACTION

Tool Set Part Number ..... CUTA1870104C  
 Procedures ..... See [Pages N26 – N30](#)  
 Line Mount Configurations..... See [Pages L6 – L8](#)  
 Replacement Pin Part Number..... JETA1870003A

*For boss size see [page N24](#). For oversize see [page N28](#).*

LEE PART NUMBER		METERED LOHM RATE	FREE FLOW LOHM RATE (Max.)	NOMINAL SCREEN HOLE SIZE (inches)
±5%	±10%			
<b>FREE FLOW FORWARD</b>				
FCFA1875100D	FCFA1870100D	1000	470	0.008
FCFA1875150D	FCFA1870150D	1500	470	0.008
FCFA1875200D	FCFA1870200D	2000	470	0.008
FCFA1875250D	FCFA1870250D	2500	470	0.008
FCFA1875300D	FCFA1870300D	3000	470	0.008
FCFA1875400D	FCFA1870400D	4000	470	0.008
FCFA1875500D	FCFA1870500D	5000	470	0.006
FCFA1875600D	FCFA1870600D	6000	470	0.006
FCFA1875800D	FCFA1870800D	8000	470	0.004
FCFA1875100H	FCFA1870100H	10000	470	0.004
FCFA1875120H	FCFA1870120H	12000	470	0.004
FCFA1875150H	FCFA1870150H	15000	470	0.004
FCFA1875200H	FCFA1870200H	20000	470	0.004
<b>FREE FLOW REVERSE</b>				
FCRA1875100D	FCRA1870100D	1000	470	0.008
FCRA1875150D	FCRA1870150D	1500	470	0.008
FCRA1875200D	FCRA1870200D	2000	470	0.008
FCRA1875250D	FCRA1870250D	2500	470	0.008
FCRA1875300D	FCRA1870300D	3000	470	0.008
FCRA1875400D	FCRA1870400D	4000	470	0.008
FCRA1875500D	FCRA1870500D	5000	470	0.006
FCRA1875600D	FCRA1870600D	6000	470	0.006
FCRA1875800D	FCRA1870800D	8000	470	0.004
FCRA1875100H	FCRA1870100H	10000	470	0.004
FCRA1875120H	FCRA1870120H	12000	470	0.004
FCRA1875150H	FCRA1870150H	15000	470	0.004
FCRA1875200H	FCRA1870200H	20000	470	0.004

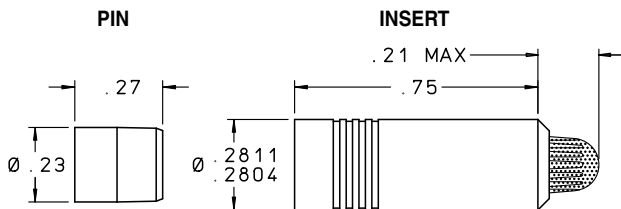

### MATERIALS

PART	MATERIAL	SPECIFICATION
Body	303 Cres	QQ-S-763C
Pin	303 Cres	QQ-S-763C
Spring Seat	303 Cres	QQ-S-763C
Orifice Plate	303 Cres	QQ-S-763C
Shuttle Plate	303 Cres	QQ-S-763C
Spring	17-7PH Cres	AMS 5678
Screen	304L Cres	ASTM A 666
Braze	—	AMS 4774

*Finish: All CRES parts passivated.*

*Pins are prewaxed. Do not degrease. Do not lubricate.*

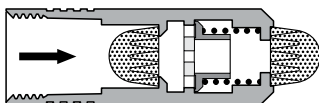

**FCFA2810250L • FREE FLOW FORWARD**

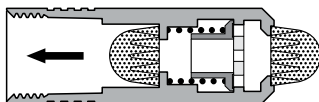

**FCRA2810250L • FREE FLOW REVERSE**

### PERFORMANCE

Metered Lohm Rate Tolerance.....	±5% or ±10%
Nominal System Pressure .....	up to 3000 psi
Cracking Pressure .....	2 - 8 psid
Free Flow Lohm Rate at ≥ 25 psid .....	175 Lohms maximum
Nominal Weight .....	4.7 grams

## INSTALLATION HOLE

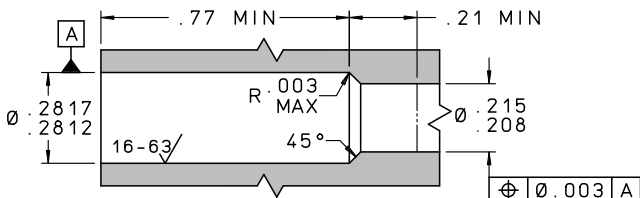

## INSTALLATION AND EXTRACTION

Tool Set Part Number ..... CUTA2810114C  
 Procedures ..... See [Pages N26 – N30](#)  
 Line Mount Configurations..... See [Pages L9 – L12](#)  
 Replacement Pin Part Number..... PRFA2810003A

*For boss size see [page N24](#). For oversize see [page N28](#).*

LEE PART NUMBER		METERED LOHM RATE	FREE FLOW LOHM RATE (Max.)	NOMINAL SCREEN HOLE SIZE (inches)
±5%	±10%			
<b>FREE FLOW FORWARD</b>				
FCFA2815250L	FCFA2810250L	250	175	0.008
FCFA2815500L	FCFA2810500L	500	175	0.008
FCFA2815750L	FCFA2810750L	750	175	0.008
FCFA2815100D	FCFA2810100D	1000	175	0.008
FCFA2815150D	FCFA2810150D	1500	175	0.008
FCFA2815200D	FCFA2810200D	2000	175	0.008
FCFA2815250D	FCFA2810250D	2500	175	0.008
FCFA2815300D	FCFA2810300D	3000	175	0.008
FCFA2815400D	FCFA2810400D	4000	175	0.008
FCFA2815500D	FCFA2810500D	5000	175	0.006
FCFA2815600D	FCFA2810600D	6000	175	0.006
FCFA2815800D	FCFA2810800D	8000	175	0.004
FCFA2815100H	FCFA2810100H	10000	175	0.004
<b>FREE FLOW REVERSE</b>				
FCRA2815250L	FCRA2810250L	250	175	0.008
FCRA2815500L	FCRA2810500L	500	175	0.008
FCRA2815750L	FCRA2810750L	750	175	0.008
FCRA2815100D	FCRA2810100D	1000	175	0.008
FCRA2815150D	FCRA2810150D	1500	175	0.008
FCRA2815200D	FCRA2810200D	2000	175	0.008
FCRA2815250D	FCRA2810250D	2500	175	0.008
FCRA2815300D	FCRA2810300D	3000	175	0.008
FCRA2815400D	FCRA2810400D	4000	175	0.008
FCRA2815500D	FCRA2810500D	5000	175	0.006
FCRA2815600D	FCRA2810600D	6000	175	0.006
FCRA2815800D	FCRA2810800D	8000	175	0.004
FCRA2815100H	FCRA2810100H	10000	175	0.004

PIN

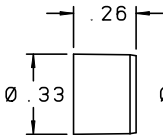

INSERT

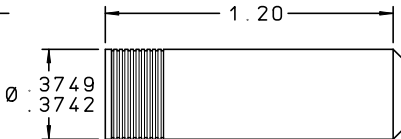

## MATERIALS

PART	MATERIAL	SPECIFICATION
Body	304 Cres	AMS 5639
Pin	17-4PH Cres	AMS 5643
Poppet	15-5PH Cres	AMS 5659
Spring	17-7PH Cres	AMS 5678
Spring Seat	304 Cres	AMS 5639

*Finish: All CRES parts passivated.*

*Pins are prewaxed. Do not degrease. Do not lubricate.*

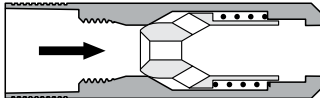

FCFA3755070L • FREE FLOW FORWARD

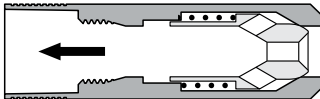

FCRA3755070L • FREE FLOW REVERSE

## PERFORMANCE

Metered Lohm Rate Tolerance.....	±5%
Nominal System Pressure .....	up to 3000 psi
Cracking Pressure .....	2 - 8 psid
Free Flow Lohm Rate at ≥ 25 psid .....	24 or 42 Lohms maximum
Nominal Weight .....	10.0 grams

### INSTALLATION HOLE

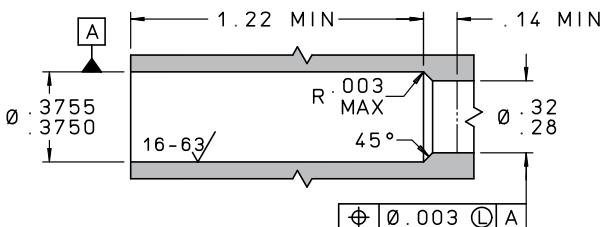

### INSTALLATION AND EXTRACTION

Tool Set Part Number ..... CUTA3750106C  
 Procedures ..... See **Pages N26 – N30**  
 Line Mount Configurations..... See **Pages L46 – L51**  
 Replacement Pin Part Number..... CKFA3750003A

*For boss size see **page N24**. For oversize see **page N28**.*

LEE PART NUMBER		METERED LOHM RATE ±5%
FREE FLOW FORWARD	FREE FLOW REVERSE	
FCFA375*070L	FCRA375*070L	70
FCFA375*080L	FCRA375*080L	80
FCFA375*095L	FCRA375*095L	95
FCFA375*110L	FCRA375*110L	110
FCFA375*130L	FCRA375*130L	130
FCFA375*150L	FCRA375*150L	150
FCFA375*175L	FCRA375*175L	175
FCFA375*200L	FCRA375*200L	200
FCFA375*230L	FCRA375*230L	230
FCFA375*260L	FCRA375*260L	260

\* Maximum Free Flow Lohm Rate:  
 5 = 24 Lohms, 6 = 42 Lohms

PIN

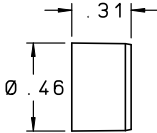

INSERT

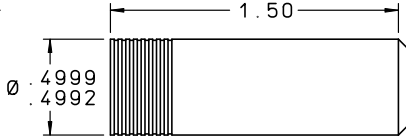

**MATERIALS**

PART	MATERIAL	SPECIFICATION
Body	304 Cres	AMS 5639
Pin	15-5PH Cres	AMS 5659
Poppet	15-5PH Cres	AMS 5659
Spring	17-7PH Cres	AMS 5678
Spring Seat	303 Cres	QQ-S-763C

*Finish: All CRES parts passivated.*

*Pins are prewaxed. Do not degrease. Do not lubricate.*

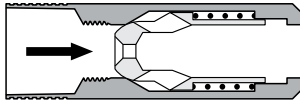

**FCFA5005040L • FREE FLOW FORWARD**

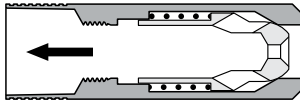

**FCRA5005040L • FREE FLOW REVERSE**

**PERFORMANCE**

Metered Lohm Rate Tolerance.....	±5%
Nominal System Pressure .....	up to 3000 psi
Cracking Pressure .....	2 - 8 psid
Free Flow Lohm Rate at ≥ 25 psid.....	12 or 24 Lohms maximum
Nominal Weight .....	20.0 grams

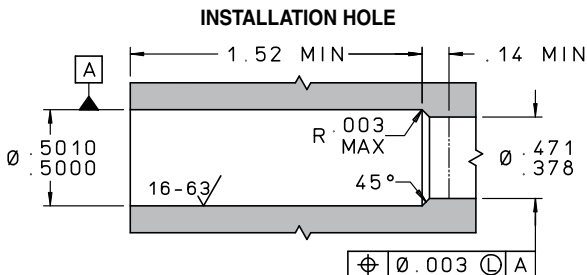

## INSTALLATION AND EXTRACTION

Tool Set Part Number ..... CUTA5000106C  
 Procedures ..... See [Pages N26 – N30](#)  
 Line Mount Configurations..... See [Pages L46 – L51](#)  
 Replacement Pin Part Number..... CKFA5000003A

*For boss size see [page N24](#). For oversize see [page N28](#).*

LEE PART NUMBER		METERED LOHM RATE $\pm 5\%$
FREE FLOW FORWARD	FREE FLOW REVERSE	
FCFA500*040L	FCRA500*040L	40
FCFA500*045L	FCRA500*045L	45
FCFA500*050L	FCRA500*050L	50
FCFA500*055L	FCRA500*055L	55
FCFA500*060L	FCRA500*060L	60
FCFA500*070L	FCRA500*070L	70
FCFA500*080L	FCRA500*080L	80
FCFA500*095L	FCRA500*095L	95
FCFA500*110L	FCRA500*110L	110
FCFA500*130L	FCRA500*130L	130
FCFA500*150L	FCRA500*150L	150
FCFA500*175L	FCRA500*175L	175
FCFA500*200L	FCRA500*200L	200
FCFA500*230L	FCRA500*230L	230
FCFA500*260L	FCRA500*260L	260

\* Maximum Free Flow Lohm Rate:  
 5 = 12 Lohms, 6 = 24 Lohms

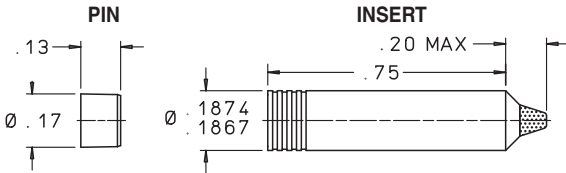

MATERIALS		
PART	MATERIAL	SPECIFICATION
Body	304 Cres	AMS 5639
Pin	15-5PH Cres	AMS 5659
Poppet	15-5PH Cres	AMS 5659
Spring	17-7PH Cres	AMS 5678
Screen	15-5PH Cres	AMS 5659

*Finish: All CRES parts passivated.  
Pins are prewaxed. Do not degrease. Do not lubricate.*

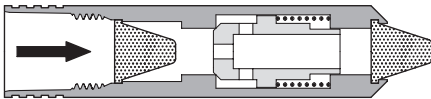

**FREE FLOW FORWARD**

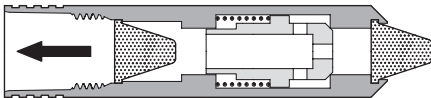

**FREE FLOW REVERSE**

PERFORMANCE	
Metered Lohm Rate Tolerance .....	±5% or ±10%
Nominal System Pressure.....	5000 psid max.
Cracking Pressure .....	2 - 8 psid
Nominal Weight .....	1.9 grams

### INSTALLATION HOLE

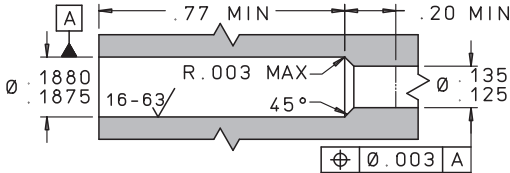

## INSTALLATION AND EXTRACTION

Tool Set Part Number ..... CUTA1870109C  
 Procedures ..... See **Pages N26 – N30**  
 Replacement Pin Part Number ..... JHHA1870003A  
*For boss size see **page N24**. For oversize see **page N28**.*

LEE PART NUMBER		METERED LOHM RATE	FREE FLOW LOHM RATE (Max.)	NOMINAL SCREEN HOLE SIZE (inches)
±5%	±10%			
<b>FREE FLOW FORWARD</b>				
FHFA1875100D	FHFA1870100D	1,000	500	0.008
FHFA1875150D	FHFA1870150D	1,500	500	0.008
FHFA1875200D	FHFA1870200D	2,000	500	0.008
FHFA1875250D	FHFA1870250D	2,500	500	0.008
FHFA1875300D	FHFA1870300D	3,000	500	0.008
FHFA1875400D	FHFA1870400D	4,000	500	0.008
FHFA1875500D	FHFA1870500D	5,000	650	0.004
FHFA1875600D	FHFA1870600D	6,000	650	0.004
FHFA1875800D	FHFA1870800D	8,000	650	0.004
FHFA1875100H	FHFA1870100H	10,000	650	0.004
FHFA1875120H	FHFA1870120H	12,000	650	0.004
FHFA1875150H	FHFA1870150H	15,000	650	0.004
FHFA1875200H	FHFA1870200H	20,000	650	0.004
<b>FREE FLOW REVERSE</b>				
FHRA1875100D	FHRA1870100D	1,000	500	0.008
FHRA1875150D	FHRA1870150D	1,500	500	0.008
FHRA1875200D	FHRA1870200D	2,000	500	0.008
FHRA1875250D	FHRA1870250D	2,500	500	0.008
FHRA1875300D	FHRA1870300D	3,000	500	0.008
FHRA1875400D	FHRA1870400D	4,000	500	0.008
FHRA1875500D	FHRA1870500D	5,000	650	0.004
FHRA1875600D	FHRA1870600D	6,000	650	0.004
FHRA1875800D	FHRA1870800D	8,000	650	0.004
FHRA1875100H	FHRA1870100H	10,000	650	0.004
FHRA1875120H	FHRA1870120H	12,000	650	0.004
FHRA1875150H	FHRA1870150H	15,000	650	0.004
FHRA1875200H	FHRA1870200H	20,000	650	0.004

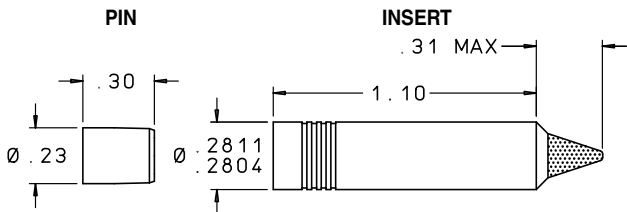

### MATERIALS

PART	MATERIAL	SPECIFICATION
Body	304 Cres	AMS 5639
Pin	15-5PH Cres	AMS 5659
Poppet	15-5PH Cres	AMS 5659
Spring	17-7PH Cres	AMS 5678
Screen	15-5PH Cres	AMS 5659

*Finish: All CRES parts passivated.*

*Pins are prewaxed. Do not degrease. Do not lubricate.*

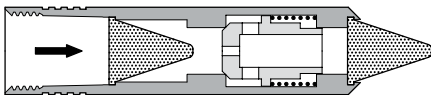

**FREE FLOW FORWARD**

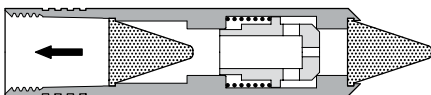

**FREE FLOW REVERSE**

### PERFORMANCE

Metered Lohm Rate Tolerance .....	±5% or ±10%
Nominal System Pressure.....	5000 psid max.
Cracking Pressure .....	2 - 8 psid
Nominal Weight .....	6.0 grams

### INSTALLATION HOLE

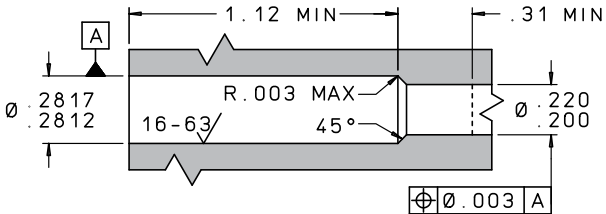

### INSTALLATION AND EXTRACTION

Tool Set Part Number ..... CUTA2810114C  
 Procedures ..... See [Pages N26 – N30](#)  
 Replacement Pin Part Number ..... SHBA281003A  
*For boss size see [page N24](#). For oversize see [page N28](#).*

LEE PART NUMBER		METERED LOHM RATE	FREE FLOW LOHM RATE (Max.)	NOMINAL SCREEN HOLE SIZE (inches)
±5%	±10%			
<b>FREE FLOW FORWARD</b>				
FHFA2815100D	FHFA2810100D	1,000	175	0.008
FHFA2815150D	FHFA2810150D	1,500	175	0.008
FHFA2815200D	FHFA2810200D	2,000	175	0.008
FHFA2815250D	FHFA2810250D	2,500	175	0.008
FHFA2815300D	FHFA2810300D	3,000	175	0.008
FHFA2815400D	FHFA2810400D	4,000	175	0.008
FHFA2815500D	FHFA2810500D	5,000	240	0.004
FHFA2815600D	FHFA2810600D	6,000	240	0.004
FHFA2815800D	FHFA2810800D	8,000	240	0.004
FHFA2815100H	FHFA2810100H	10,000	240	0.004
<b>FREE FLOW REVERSE</b>				
FHRA2815100D	FHRA2810100D	1,000	175	0.008
FHRA2815150D	FHRA2810150D	1,500	175	0.008
FHRA2815200D	FHRA2810200D	2,000	175	0.008
FHRA2815250D	FHRA2810250D	2,500	175	0.008
FHRA2815300D	FHRA2810300D	3,000	175	0.008
FHRA2815400D	FHRA2810400D	4,000	175	0.008
FHRA2815500D	FHRA2810500D	5,000	240	0.004
FHRA2815600D	FHRA2810600D	6,000	240	0.004
FHRA2815800D	FHRA2810800D	8,000	240	0.004
FHRA2815100H	FHRA2810100H	10,000	240	0.004

## PIN

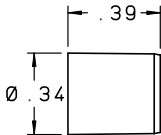

## INSERT

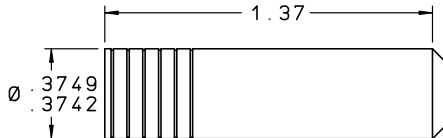

## MATERIALS

PART	MATERIAL	SPECIFICATION
Body	304 Cres	AMS 5639
Pin	17-4PH Cres	AMS 5643
Poppet	15-5PH Cres	AMS 5659
Spring	17-7PH Cres	AMS 5678
Spring Seat	304 Cres	AMS 5639

*Finish: All CRES parts passivated.*

*Pins are prewaxed. Do not degrease. Do not lubricate.*

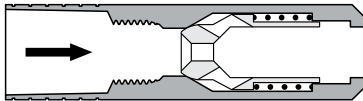

**FHFA3755070L • FREE FLOW FORWARD**

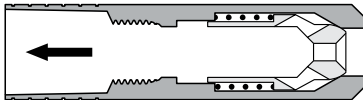

**FHRA3755070L • FREE FLOW REVERSE**

## PERFORMANCE

Metered Lohm Rate Tolerance .....	±5%
Nominal System Pressure .....	up to 8000 psi
Cracking Pressure .....	2 - 8 psid
Free Flow Lohm Rate at ≥ 25 psid.....	27 Lohms maximum
Nominal Weight .....	13 grams

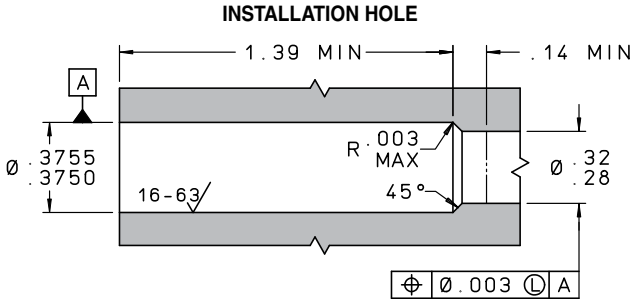

## INSTALLATION AND EXTRACTION

Tool Set Part Number ..... CUTA3750106C

Procedures ..... See **Pages N26 – N30**

Line Mount Configurations..... See **Page L46 – L47**

Replacement Pin Part Number..... PHRA3750003A

*For boss size see **page N24**. For oversize see **page N28**.*

LEE PART NUMBER		METERED LOHM RATE ±5%	FREE FLOW LOHM RATE (Max.)
FREE FLOW FORWARD	FREE FLOW REVERSE		
FHFA3755070L	FHRA3755070L	70	27
FHFA3755080L	FHRA3755080L	80	27
FHFA3755095L	FHRA3755095L	95	27
FHFA3755110L	FHRA3755110L	110	27
FHFA3755130L	FHRA3755130L	130	27
FHFA3755150L	FHRA3755150L	150	27
FHFA3755175L	FHRA3755175L	175	27
FHFA3755200L	FHRA3755200L	200	27
FHFA3755230L	FHRA3755230L	230	27
FHFA3755260L	FHRA3755260L	260	27

PIN

INSERT

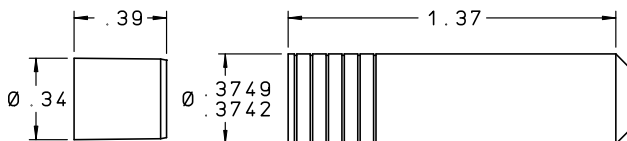

### MATERIALS

PART	MATERIAL	SPECIFICATION
Body	304 Cres	AMS 5639
Pin	17-4PH Cres	AMS 5643
Poppet	15-5PH Cres	AMS 5659
Spring	17-7PH Cres	AMS 5678
Spring Seat	304 Cres	AMS 5639
Orifice Plate	17-4PH Cres	AMS 5643
Screen	15-5PH Cres	AMS 5659

*Finish: All CRES parts passivated.*

*Pins are prewaxed. Do not degrease. Do not lubricate.*

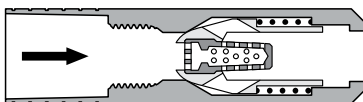

**FREE FLOW FORWARD**

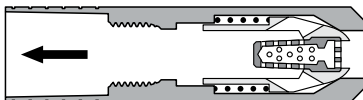

**FREE FLOW REVERSE**

### PERFORMANCE

Metered Lohm Rate Tolerance .....	±5%
Nominal System Pressure .....	up to 5000 psi
Cracking Pressure .....	2 - 8 psid
Free Flow Lohm Rate at ≥ 25 psid.....	28 Lohms maximum
Nominal Weight .....	13 grams

## INSTALLATION HOLE

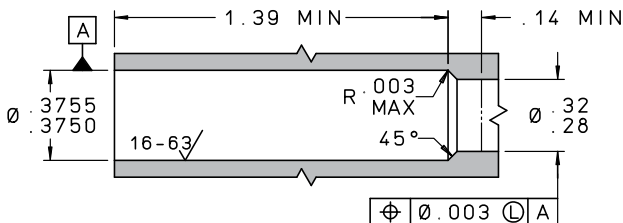

## INSTALLATION AND EXTRACTION

Tool Set Part Number ..... CUTA3750106C

Procedures ..... See **Pages N26 – N30**

Replacement Pin Part Number ..... PHRA3750003A

*For boss size see **page N24**. For oversize see **page N28**.*

LEE PART NUMBER		METERED LOHM RATE ±5%	FREE FLOW LOHM RATE (Max.)	NOMINAL SCREEN HOLE SIZE (inches)
FREE FLOW FORWARD	FREE FLOW REVERSE			
FHFA3755300L	FHRA3755300L	300	28	0.024
FHFA3755400L	FHRA3755400L	400	28	0.024
FHFA3755500L	FHRA3755500L	500	28	0.024
FHFA3755600L	FHRA3755600L	600	28	0.020
FHFA3755700L	FHRA3755700L	700	28	0.020
FHFA3755800L	FHRA3755800L	800	28	0.015
FHFA3755900L	FHRA3755900L	900	28	0.015
FHFA3755100D	FHRA3755100D	1000	28	0.015
FHFA3755120D	FHRA3755120D	1200	28	0.012
FHFA3755140D	FHRA3755140D	1400	28	0.012
FHFA3755160D	FHRA3755160D	1600	28	0.012
FHFA3755180D	FHRA3755180D	1800	28	0.012
FHFA3755200D	FHRA3755200D	2000	28	0.012
FHFA3755240D	FHRA3755240D	2400	28	0.008
FHFA3755280D	FHRA3755280D	2800	28	0.008
FHFA3755320D	FHRA3755320D	3200	28	0.008

PIN

INSERT

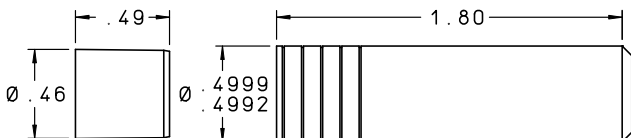

MATERIALS		
PART	MATERIAL	SPECIFICATION
Body	304 Cres	AMS 5639
Pin	15-5PH Cres	AMS 5659
Poppet	15-5PH Cres	AMS 5659
Spring	17-7PH Cres	AMS 5678
Spring Seat	303 Cres	QQ-S-763C

*Finish: All CRES parts passivated.*

*Pins are prewaxed. Do not degrease. Do not lubricate.*

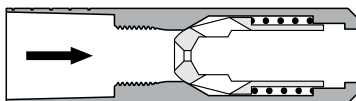

**FHFA5005040L • FREE FLOW FORWARD**

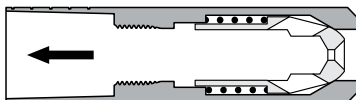

**FHRA5005040L • FREE FLOW REVERSE**

PERFORMANCE	
Metered Lohm Rate Tolerance .....	±5%
Nominal System Pressure .....	up to 8000 psi
Cracking Pressure .....	2 - 8 psid
Free Flow Lohm Rate at ≥ 25 psid.....	15 Lohms maximum
Nominal Weight .....	29 grams

INSTALLATION HOLE

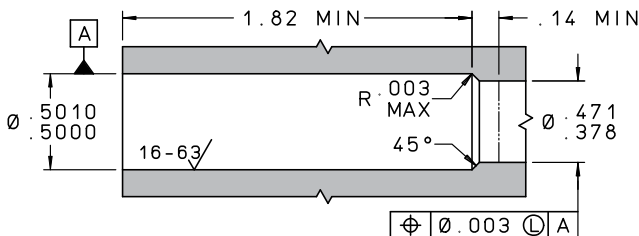

INSTALLATION AND EXTRACTION

Tool Set Part Number ..... CUTA5000206C  
 Procedures ..... See **Pages N26 – N30**  
 Line Mount Configurations..... See **Page L46 – L47**  
 Replacement Pin Part Number..... CHFA5000003A

*For boss size see **page N24**. For oversize see **page N28**.*

LEE PART NUMBER		METERED LOHM RATE ±5%	FREE FLOW LOHM RATE (Max.)
FREE FLOW FORWARD	FREE FLOW REVERSE		
FHFA5005040L	FHRA5005040L	40	15
FHFA5005045L	FHRA5005045L	45	15
FHFA5005050L	FHRA5005050L	50	15
FHFA5005055L	FHRA5005055L	55	15
FHFA5005060L	FHRA5005060L	60	15
FHFA5005070L	FHRA5005070L	70	15
FHFA5005080L	FHRA5005080L	80	15
FHFA5005095L	FHRA5005095L	95	15
FHFA5005110L	FHRA5005110L	110	15
FHFA5005130L	FHRA5005130L	130	15
FHFA5005150L	FHRA5005150L	150	15
FHFA5005175L	FHRA5005175L	175	15
FHFA5005200L	FHRA5005200L	200	15
FHFA5005230L	FHRA5005230L	230	15
FHFA5005260L	FHRA5005260L	260	15

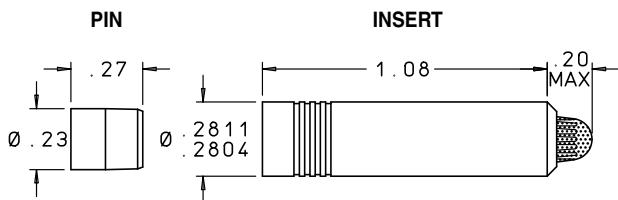

### MATERIALS

PART	MATERIAL	SPECIFICATION
Body	303 Cres	QQ-S-763C
Pin	303 Cres	QQ-S-763C
Piston	416 Cres	QQ-S-763C
Spool	440C Cres	AMS 5630
Spring	17-7PH Cres	AMS 5678
Screen	304L Cres	ASTM A 666
Braze	—	AMS 4774

*Finish: All CRES parts passivated.*

*Pins are prewaxed. Do not degrease. Do not lubricate.*

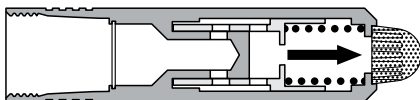

**FLFA2812310D • REGULATED FLOW FORWARD**

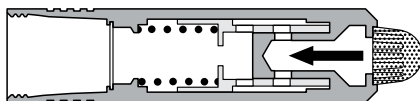

**FLRA2812310D • REGULATED FLOW REVERSE**

### PERFORMANCE

Regulated Flow Tolerance .....	±10%
Nominal Screen Hole Size .....	0.015"
Nominal System Pressure .....	up to 3000 psi
Nominal Weight .....	6.4 grams

## INSTALLATION HOLE

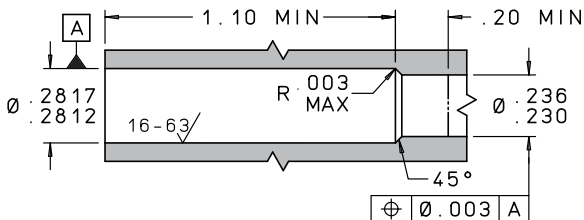

## INSTALLATION AND EXTRACTION

Tool Set Part Number ..... CUTA2810114C  
 Procedures ..... See **Pages N26 – N30**  
 Line Mount Configurations..... See **Pages L9 – L12**  
 Replacement Pin Part Number..... PRFA2810003A  
*For boss size see **page N24**. For oversize see **page N28**.*

LEE PART NUMBER		REGULATED FLOW MIL-PRF-83282 (GPM at 85°F)	FLOW REGULATION RANGE (psi)		NOMINAL LOHM RATE NON REGULATING FLOW DIRECTION
REGULATED FLOW FORWARD	REGULATED FLOW REVERSE		ΔP Min.	ΔP Max.	
FLFA2812310D	FLRA2812310D	1.0	200	3000	280
FLFA2812390L	FLRA2812390L	0.9	175	3000	300
FLFA2812380L	FLRA2812380L	0.8	150	3000	340
FLFA2812370L	FLRA2812370L	0.7	125	3000	380
FLFA2812360L	FLRA2812360L	0.6	100	3000	425
FLFA2812350L	FLRA2812350L	0.5	100	3000	485
FLFA2812340L	FLRA2812340L	0.4	100	3000	550
FLFA2812335L	FLRA2812335L	0.35	100	3000	625
FLFA2812330L	FLRA2812330L	0.3	100	3000	680
FLFA2812325L	FLRA2812325L	0.25	100	3000	800
FLFA2812320L	FLRA2812320L	0.2	100	3000	850
FLFA2812315L	FLRA2812315L	0.15	100	3000	1600
FLFA2812310L	FLRA2812310L	0.1	100	3000	1900

# 28 500 Flosert

**PIN**

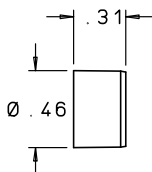

**INSERT**

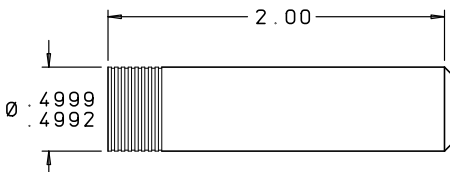

## MATERIALS

PART	MATERIAL	SPECIFICATION
Body	303 Cres	QQ-S-763C
Pin	15-5PH Cres	AMS 5659
Sleeve	416 Cres	QQ-S-763C
Spring	17-7PH Cres	AMS 5678
Piston	440C Cres	AMS 5630

*Finish: All CRES parts passivated.*

*Pins are prewaxed. Do not degrease. Do not lubricate.*

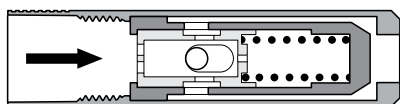

**FLFA5001350D • REGULATED FLOW FORWARD**

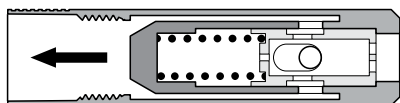

**FLRA5001350D • REGULATED FLOW REVERSE**

## PERFORMANCE

Regulated Flow Tolerance .....	±10%
Nominal System Pressure .....	up to 3000 psi
Nominal Weight .....	28 grams

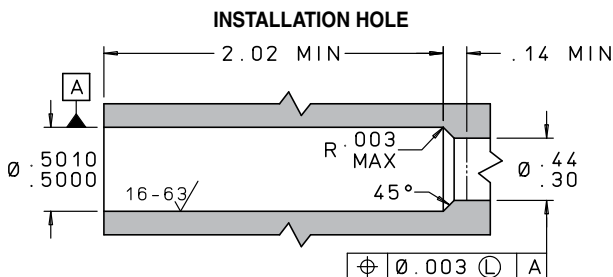

## INSTALLATION AND EXTRACTION

Tool Set Part Number ..... CUTA5000116C  
 Procedures ..... See **Pages N26 – N30**  
 Replacement Pin Part Number..... CKFA5000003A

*For boss size see **page N24**. For oversize see **page N28**.*

LEE PART NUMBER		REGULATED FLOW MIL-PRF-83282 (GPM at 85°F)	FLOW REGULATION RANGE (psi)		NOMINAL LOHM RATE NON REGULATING FLOW DIRECTION
			$\Delta P$ Min.	$\Delta P$ Max.	
REGULATED FLOW FORWARD	REGULATED FLOW REVERSE				
FLFA5001350D	FLRA5001350D	5.0	150	3000	60
FLFA5001345D	FLRA5001345D	4.5	125	3000	60
FLFA5001340D	FLRA5001340D	4.0	125	3000	65
FLFA5001335D	FLRA5001335D	3.5	100	3000	70
FLFA5001330D	FLRA5001330D	3.0	100	3000	80
FLFA5001325D	FLRA5001325D	2.5	100	3000	95
FLFA5001320D	FLRA5001320D	2.0	100	3000	120
FLFA5001315D	FLRA5001315D	1.5	100	3000	150

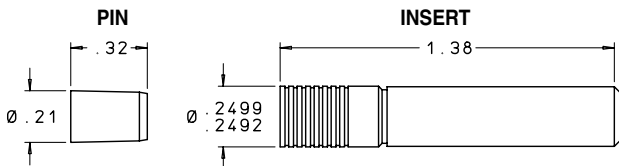

### MATERIALS

PART	MATERIAL	SPECIFICATION
Rear Body	304 Cres	AMS 5639
Front Body	303 Cres	QQ-S-763C
Seat	303 Cres	QQ-S-763C
Screen Retainer	303 Cres	QQ-S-763C
Spring Seat	303 Cres	QQ-S-763C
Screens	316L Cres	ASTM A 478 and ASTM A 666 or AMS 5653
Braze	Silver Alloy	AMS 4765
Piston	303 Cres	QQ-S-763C
Internal Seal	PTFE/302 Cres or MP35N	—
Spring	17-7PH Cres	AMS 5678
Metering Discs	17-7PH Cres	AMS 5529
Visco Stack	304L Cres	ASTM A 666
Shim, Spacers, Washers	303 Cres	QQ-S-763C or ASTM A 666
Pin	17-4PH Cres	AMS 5643

*Finish: All CRES parts passivated.*

*Pins are prewaxed. Do not degrease. Do not lubricate.*

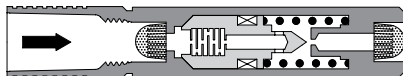

**REGULATED FLOW FORWARD**

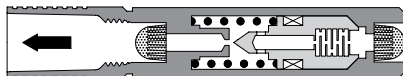

**REGULATED FLOW REVERSE**

### PERFORMANCE

Regulated Flow Tolerance .....	+/-15%
Nominal System Pressure.....	up to 5000 psi
Nominal Weight .....	6 grams

### INSTALLATION HOLE

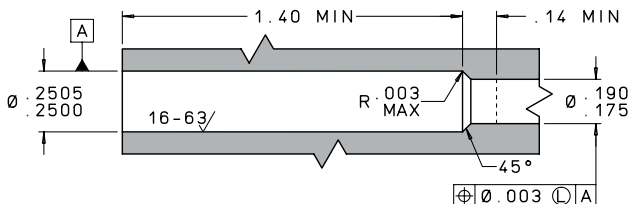

### INSTALLATION AND EXTRACTION

Tool Set Part Number ..... CUTA2500116C  
 Procedures ..... See [Pages N26 – N30](#)  
 Replacement Pin Part Number..... CHFA2500003A

*For boss size see [page N24](#). For oversize see [page N28](#).*

LEE PART NUMBER		REGULATED FLOW MIL-PRF-83282 (GPM at 85°F ± 15°F)	FLOW REGULATION RANGE (psi)		NOMINAL LOHM RATE NON REGULATING FLOW DIRECTION
REGULATED FLOW FORWARD	REGULATED FLOW REVERSE		ΔP Min.	ΔP Max.	
FLFA2504510L	FLRA2504510L	0.10	500	5000	3500
FLFA2504509L	FLRA2504509L	0.09	500	5000	3800
FLFA2504508L	FLRA2504508L	0.08	500	5000	4300
FLFA2504507L	FLRA2504507L	0.07	500	5000	4900
FLFA2504506L	FLRA2504506L	0.06	500	5000	5800
FLFA2504505L	FLRA2504505L	0.05	500	5000	6900
FLFA2504504L	FLRA2504504L	0.04	500	5000	8600
FLFA2504503L	FLRA2504503L	0.03	500	5000	12000
FLFA2504502L	FLRA2504502L	0.02	500	5000	24000
FLFA2504501L	FLRA2504501L	0.01	500	5000	41000

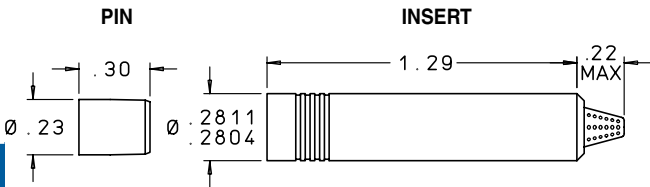
**MATERIALS**

PART	MATERIAL	SPECIFICATION
Body	15-5PH Cres	AMS 5659
Pin	15-5PH Cres	AMS 5659
Filter Screens	15-5PH Cres	AMS 5659
Spring Seat	304 Cres	AMS 5639
Spool	13-8 MO	AMS 5629
Orifice Plate	304 Cres	ASTM-A-666
Piston	416 Cres	QQ-S-763C
Spring	17-7PH Cres	AMS 5678
Internal Seal	GFP with 316 or MP35N Spring	—

*Finish: All CRES parts passivated.*

*Pins are prewaxed. Do not degrease. Do not lubricate.*

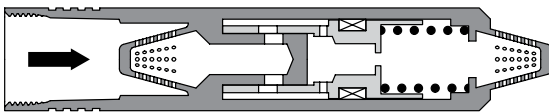
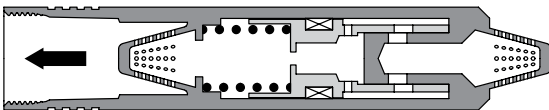
**REGULATED FLOW FORWARD****REGULATED FLOW REVERSE****PERFORMANCE**

Regulated Lohm Rate Tolerance.....	±10%
Nominal System Pressure .....	up to 5000 psi
Nominal Weight.....	7 grams

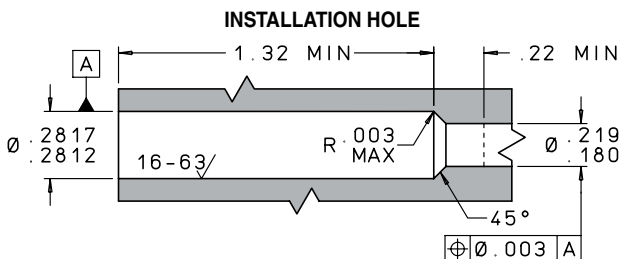

## INSTALLATION AND EXTRACTION

Tool Set Part Number ..... CUTA2810114C  
 Procedures ..... See **Pages N26 – N30**  
 Replacement Pin Part Number ..... SHBA2810003A  
*For boss size see **page N24**. For oversize see **page N28**.*

LEE PART NUMBER		REGULATED FLOW MIL-PRF-83282 (GPM at 85°F ± 15°F)	FLOW REGULATION RANGE (psi)		NOMINAL LOHM RATE NON REGULATING FLOW DIRECTION
REGULATED FLOW FORWARD	REGULATED FLOW REVERSE		ΔP Min.	ΔP Max.	
FLFA2812510D	FLRA2812510D	1.0	200	5000	280
FLFA2812590L	FLRA2812590L	0.9	175	5000	300
FLFA2812580L	FLRA2812580L	0.8	150	5000	340
FLFA2812570L	FLRA2812570L	0.7	125	5000	380
FLFA2812560L	FLRA2812560L	0.6	100	5000	425
FLFA2812550L	FLRA2812550L	0.5	100	5000	485
FLFA2812540L	FLRA2812540L	0.4	100	5000	550
FLFA2812535L	FLRA2812535L	0.35	100	5000	625
FLFA2812530L	FLRA2812530L	0.3	100	5000	680
FLFA2812525L	FLRA2812525L	0.25	100	5000	800
FLFA2812520L	FLRA2812520L	0.2	100	5000	850
FLFA2812515L	FLRA2812515L	0.15	100	5000	1600
FLFA2812510L	FLRA2812510L	0.1	100	5000	1900

PIN

INSERT

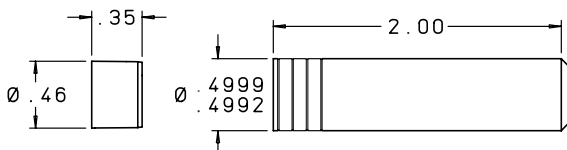

## MATERIALS

PART	MATERIAL	SPECIFICATION
Body	15-5PH Cres	AMS 5659
Pin	15-5PH Cres	AMS 5659
Sleeve	416 Cres	QQ-S-763C
Spring	17-7PH Cres	AMS 5678
Piston	440C Cres	AMS 5630
Spring Seat	303 Cres	QQ-S-763C
Retainer	13-8 MO Cres	AMS 5629
Washer	15-5PH Cres	AMS 5659
Damping Orifice	303 Cres	QQ-S-763C

*Finish: All CRES parts passivated.*

*Pins are prewaxed. Do not degrease. Do not lubricate.*

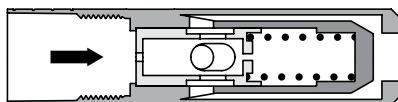

REGULATED FLOW FORWARD

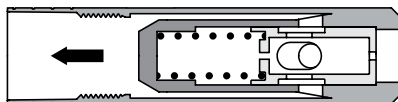

REGULATED FLOW REVERSE

## PERFORMANCE

Metered Lohm Rate Tolerance .....	±10%
Nominal System Pressure.....	up to 5000 psi
Nominal Weight .....	32 grams

## INSTALLATION HOLE

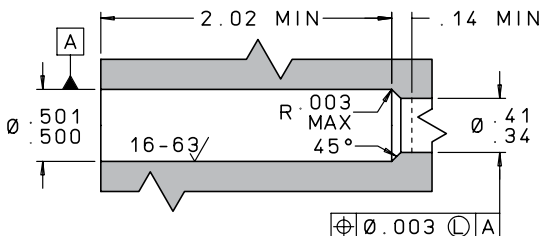

## INSTALLATION AND EXTRACTION

Tool Set Part Number ..... CUTA5000716C  
 Procedures ..... See [Pages N26 – N30](#)  
 Replacement Pin Part Number ..... SVBA5000003A

*For boss size see [page N24](#). For oversize see [page N28](#).*

LEE PART NUMBER		REGULATED FLOW MIL-PRF-83282 (GPM at 85°F ± 15°F)	FLOW REGULATION RANGE (psi)		NOMINAL LOHM RATE NON REGULATING FLOW DIRECTION
REGULATED FLOW FORWARD	REGULATED FLOW REVERSE		ΔP Min.	ΔP Max.	
FLFA5001550D	FLRA5001550D	5.0	200	5000	80
FLFA5001545D	FLRA5001545D	4.5	175	5000	80
FLFA5001540D	FLRA5001540D	4.0	175	5000	85
FLFA5001535D	FLRA5001535D	3.5	150	5000	90
FLFA5001530D	FLRA5001530D	3.0	150	5000	100
FLFA5001525D	FLRA5001525D	2.5	125	5000	115
FLFA5001520D	FLRA5001520D	2.0	100	5000	140
FLFA5001515D	FLRA5001515D	1.5	100	5000	170

PIN

INSERT

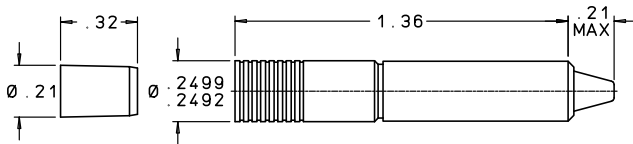

**MATERIALS**

PART	MATERIAL	PART	MATERIAL
Body	MP35N	Spacers	MP35N
Loading Washer	MP35N	Spring Seat	MP35N
Nose	MP35N	Spring	MP35N or Elgiloy®
Optional Shims	MP35N	Metering Discs	316L Cres or MP35N
Pin	MP35N	Shim	316L Cres or MP35N
Piston	MP35N	Internal Seal	PTFE with MP35N or Elgiloy Spring
Screens	MP35N	—	—

*Finish: All CRES parts passivated.*

*Pins are prewaxed. Do not degrease. Do not lubricate.*

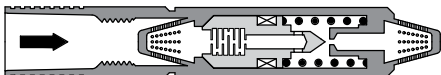

**REGULATED FLOW FORWARD**

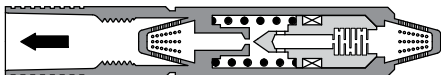

**REGULATED FLOW REVERSE**

**PERFORMANCE**

- Regulated Flow Tolerance from Minimum – 5000 psid ... ±15%
- Regulated Flow Tolerance from 5001-8000 psid ..... ±20%
- Nominal System Pressure ..... up to 8000 psi
- Nominal Weight ..... 6 grams
- Nominal Screen Hole Size ..... 0.008"

*Elgiloy® is a registered tradename of Elgiloy Specialty Metals, Inc.*

## INSTALLATION HOLE

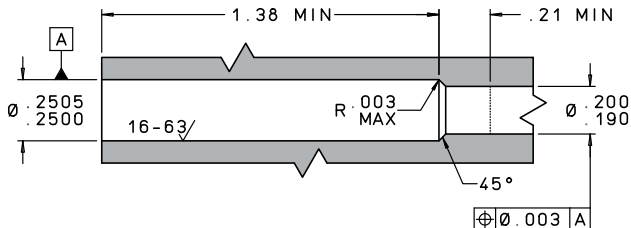

## INSTALLATION AND EXTRACTION

Tool Set Part Number ..... CUTA250116C  
 Procedures ..... See [Pages N26 – N30](#)  
 Replacement Pin Part Number ..... FLFX0512880B

*For boss size see [page N24](#). For oversize see [page N28](#).*

LEE PART NUMBER		REGULATED FLOW MIL-PRF-83282 (at 85°F ± 15°F)	FLOW REGULATION RANGE (psi)		NOMINAL LOHM RATE NON REGULATING FLOW DIRECTION
			ΔP Min.	ΔP Max.	
FORWARD	REVERSE	FLOW (GPM)			
FLFA2507801L	FLRA2507801L	0.01	500	8000	35 000
FLFA2507802L	FLRA2507802L	0.02	500	8000	17 000
FLFA2507803L	FLRA2507803L	0.03	500	8000	12 000
FLFA2507804L	FLRA2507804L	0.04	500	8000	8600
FLFA2507805L	FLRA2507805L	0.05	500	8000	6900
FLFA2507806L	FLRA2507806L	0.06	500	8000	5800
FLFA2507807L	FLRA2507807L	0.07	500	8000	4900
FLFA2507808L	FLRA2507808L	0.08	500	8000	4300
FLFA2507809L	FLRA2507809L	0.09	500	8000	3800
FLFA2507810L	FLRA2507810L	0.10	500	8000	3500

PIN

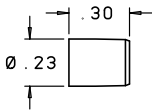

INSERT

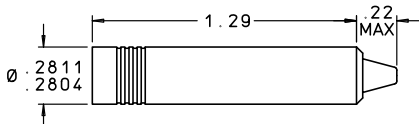

**MATERIALS**

PART	MATERIAL	PART	MATERIAL
Body	MP35N	Piston	MP35N
Filter Screens	MP35N	Spool	MP35N
Orifice Plate	MP35N	Spring Seat	MP35N
Pin	MP35N	Spring	MP35N or Elgiloy®

*Pins are prewaxed. Do not degrease. Do not lubricate.*

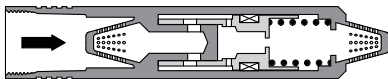

**REGULATED FLOW FORWARD**

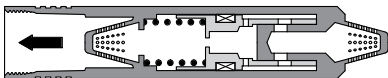

**REGULATED FLOW REVERSE**

**PERFORMANCE**

- \*Regulated Flow Tolerance from Minimum – 5000 psid.. ±10%
- \*Regulated Flow Tolerance from 5001-8000 psid..... ±15%
- Nominal System Pressure ..... up to 8000 psi
- Nominal Weight ..... 8 grams
- Nominal Screen Hole Size..... 0.015"

**\*FOR REGULATED FLOW 0.2 & 0.3**

- \*Regulated Flow Tolerance from Minimum – 5000 psid.. ±15%
- \*Regulated Flow Tolerance from 5001-8000 psid..... ±20%

*Elgiloy® is a registered tradename of Elgiloy Specialty Metals, Inc.*

INSTALLATION HOLE

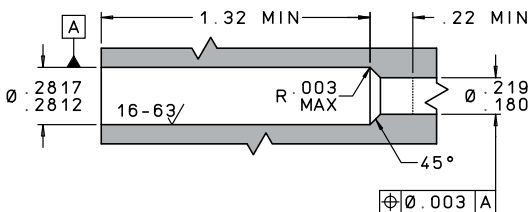

INSTALLATION AND EXTRACTION

Tool Set Part Number ..... CUTA2810114C  
 Procedures ..... See **Pages N26 – N30**  
 Replacement Pin Part Number ..... PRRX0549720B  
*For boss size see **page N24**. For oversize see **page N28**.*

LEE PART NUMBER		REGULATED FLOW MIL-PRF-83282 (at 85°F ± 15°F)	FLOW REGULATION RANGE (psi)		NOMINAL LOHM RATE NON REGULATING FLOW DIRECTION
			ΔP Min.	ΔP Max.	
FORWARD	REVERSE	FLOW (GPM)			
FLFA2816820L	FLRA2816820L	0.2	200	8000	850
FLFA2816830L	FLRA2816830L	0.3	200	8000	680
FLFA2816840L	FLRA2816840L	0.4	200	8000	550
FLFA2816850L	FLRA2816850L	0.5	200	8000	490
FLFA2816860L	FLRA2816860L	0.6	200	8000	430
FLFA2816870L	FLRA2816870L	0.7	200	8000	380
FLFA2816880L	FLRA2816880L	0.8	200	8000	340
FLFA2816890L	FLRA2816890L	0.9	200	8000	300
FLFA2816810D	FLRA2816810D	1.0	200	8000	280
FLFA2816811D	FLRA2816811D	1.1	200	8000	280
FLFA2816812D	FLRA2816812D	1.2	200	8000	250

PIN

INSERT

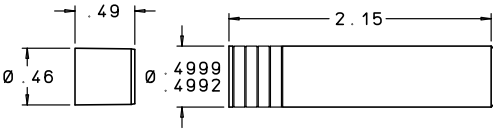

**MATERIALS**

PART	MATERIAL	PART	MATERIAL
Body	MP35N	Sleeve	MP35N
Damping Orifice	MP35N	Spring Seat	MP35N
Pin	MP35N	Washer	MP35N
Piston	MP35N	Spring	MP35N or Elgiloy®
Retainer	MP35N	—	—

*Pins are prewaxed. Do not degrease. Do not lubricate.*

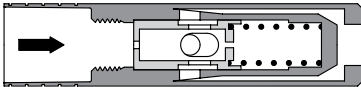

**REGULATED FLOW FORWARD**

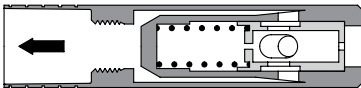

**REGULATED FLOW REVERSE**

**PERFORMANCE**

Regulated Flow Tolerance from Minimum – 5000 psid ... ±10%  
 Regulated Flow Tolerance from 5001-8000 psid ..... ±15%  
 Nominal System Pressure ..... up to 8000 psi  
 Nominal Weight ..... 40 grams

## INSTALLATION HOLE

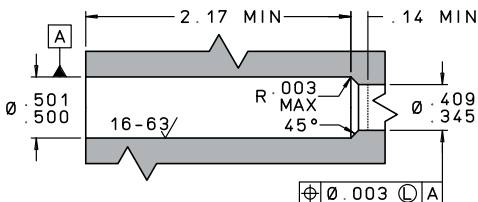

## INSTALLATION AND EXTRACTION

Tool Set Part Number ..... CUTA5000206C  
 Procedures ..... See [Pages N26 – N30](#)  
 Replacement Pin Part Number ..... CHFA5000353A

*For boss size see [page N24](#). For oversize see [page N28](#).*

LEE PART NUMBER		REGULATED FLOW MIL-PRF-83282 (at 85°F ± 15°F)	FLOW REGULATION RANGE (psi)		NOMINAL LOHM RATE NON REGULATING FLOW DIRECTION
			ΔP Min.	ΔP Max.	
FORWARD	REVERSE	FLOW (GPM)			
FLFA5005813D	FLRA5005813D	1.3	200	8000	200
FLFA5005814D	FLRA5005814D	1.4	200	8000	190
FLFA5005815D	FLRA5005815D	1.5	200	8000	170
FLFA5005820D	FLRA5005820D	2.0	200	8000	140
FLFA5005825D	FLRA5005825D	2.5	200	8000	120
FLFA5005830D	FLRA5005830D	3.0	200	8000	100
FLFA5005835D	FLRA5005835D	3.5	200	8000	90
FLFA5005840D	FLRA5005840D	4.0	200	8000	90
FLFA5005845D	FLRA5005845D	4.5	200	8000	80
FLFA5005850D	FLRA5005850D	5.0	200	8000	80

# Nozzles

D

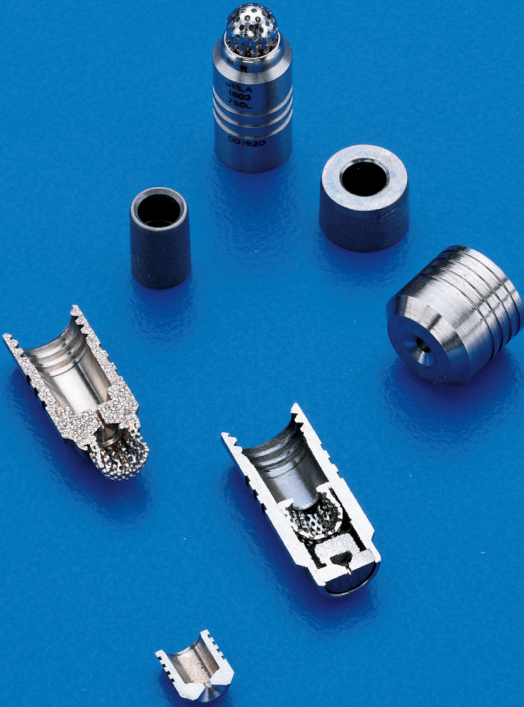



- Hollow-cone, Pressure-atomized Spray**
- Miniaturized, Economical, Field-proven**
- All Stainless Steel Construction**
- Extractable, Reusable**
- Safety Screen Protection**

D



- Accurate, Solid Stream, Lubricating Jet**
- Tested for Flow and Target-Hitting Ability**
- Available in Unidirectional or Bidirectional Flow**
- Lube Oil, Cooling Oil, Fuel Applications**
- Safety Screen Protection Available**

**TABLE OF CONTENTS**

<b>Lee Spin Jet</b>	Provides hollow cone pressure-atomized spray..	2, 4 – 5
<b>Lee Lubrication Jet</b>	Accurately directs liquid to target location.....	3, 6 – 17
<b>Lee Custom Nozzles</b>	Custom nozzles .....	18

**MINIATURE PRECISION NOZZLES**

The Lee Company offers two types of miniature precision nozzles: the Spin Jet and the Lubrication Jet. Both types are constructed entirely from stainless steel for compatibility with most industrial and aerospace liquids. Both incorporate the unique installation and retention principle used in the already proven and qualified Lee valves and restrictors. Their small size and light weight make them extremely cost effective.

All Lee nozzles can be installed in any attitude; you simply install the insert in a reamed hole, and lock and seal it by pressing the pin in the insert. This easy installation eliminates costly assemblies, seals, and threads, yet the nozzles can be readily removed whenever necessary. Lee nozzles are the most compact, economical, and reliable nozzles available anywhere.

**LEE SPIN JETS**

Lee Spin Jets utilize unique vortices and flow passages to provide a finely atomized hollow cone spray pattern. When used with most normal fuels, Spin Jets produce a 70° cone angle spray with differential pressure in the

50-200 psi range. With liquids having surface tension in the 0.002-0.005 lb./ft. range, the droplet size is typically less than 150  $\mu\text{m}$ . Four convenient part numbers, spanning the range from 6,000 to 18,000 Lohms, are available, each with a safety screen to protect against rogue particles. The recommended maximum service temperature is 700°F (371°C), and for continuous service is 400°F (204°C).

## LEE LUBRICATION JETS

Lee Lubrication Jets generate a straight, well-defined stream of fluid to a predetermined target with differential pressures of 10 to 200 psid. These units are ideal for directing streams of lubricating oil at critical bearings, or cooling oil at meshing gears, or fuel at the inside of vaporizing tubes in aircraft combustion chambers.

A total of 43 different standard units are available and are summarized in the following table:

	<b>SCREENED LUBRICATION JETS</b>	<b>UNSCREENED LUBRICATION JETS</b>
Body Diameter	0.187"	0.125", 0.187", 0.250", 0.343"
Lohm Rate	500 - 7,500	200 - 2,250
Lohm Rate Tolerance	$\pm 10\%$	$\pm 15\%$
Flow Direction	Forward or Reverse	Bidirectional
Max. Working Pressure	3,000 psid	1500 psid
Extraction Threads	Yes	No
Installation Hole Tolerance	0.0005"	0.0025"

The recommended maximum temperature for using Lee Lubrication Jets containing integral safety screens is 700°F (371°C) short term, and 400°F (204°C) for continuous service.

# 4

# Lee Spin Jet

D

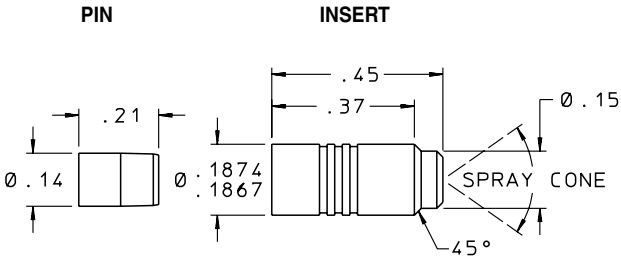

MATERIALS		
PART	MATERIAL	SPECIFICATION
Body	303 Cres	QQ-S-763C
Pin	303 Cres	QQ-S-763C
Spin Insert	303 Cres	QQ-S-763C
Screen	304L Cres	ASTM A 666
Base Washer	304L Cres	ASTM A 666
Braze	—	AWS A5.8 BNi-7

*Finish: All Cres Parts Passivated.*

*Pins are prewaxed. Do not degrease. Do not lubricate.*

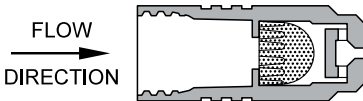

PERFORMANCE	
Lohm Rate Tolerance.....	$\pm 10\%$
Differential Pressure (Recommended).....	50-200 psid
Maximum Working Pressure.....	200 psid
Spray Cone Angle (Nominal).....	$70^\circ$
Nominal Weight .....	1.2 grams

## INSTALLATION HOLE

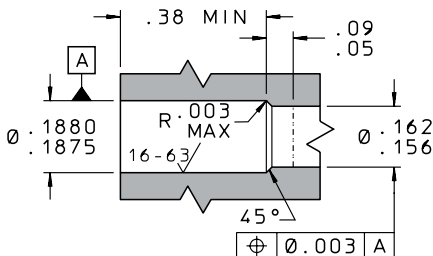

## INSTALLATION AND EXTRACTION

Tool Set Part Number ..... CUTA1870104C

Procedures..... See [Page N26 – N30](#)

Replacement Pin Part Number..... JETA1870003A

*For boss size see [page N24](#). For oversize see [page N28](#).*

LEE PART NUMBER	LOHM RATE	MIN. PASSAGE SIZE (Inches)	NOMINAL SCREEN HOLE DIA. (Inches)	REF. FLOW RATE MIL-C-7024 TYPE II @ 50 psid & 80°F (pph)
NZSA1801600D	6000	0.012	0.008	10
NZSA1801900D	9000	0.010	0.008	7
NZSA1801120H	12000	0.008	0.006	5
NZSA1801180H	18000	0.009	0.006	3.5

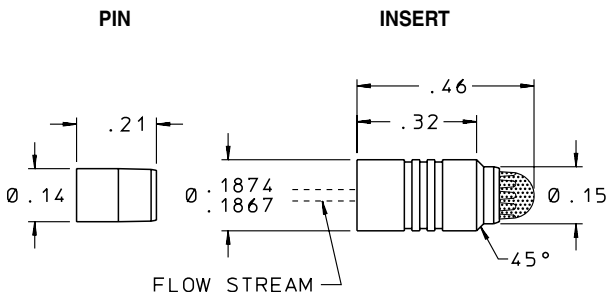

### MATERIALS

PART	MATERIAL	SPECIFICATION
Body	303 Cres	QQ-S-763C
Pin	17-4PH Cres	AMS 5643
Screen	304L Cres	ASTM A 666
Base Washer	304L Cres	ASTM A 666
Braze	—	AMS 4774

*Finish: All Cres Parts Passivated.*

*Pins are prewaxed. Do not degrease. Do not lubricate.*

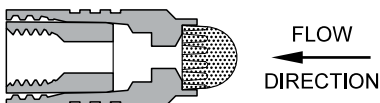

### PERFORMANCE

Lohm Rate Tolerance.....	± 10%
Differential Pressure (Recommended).....	10-200 psid
Flow to hit 0.25" diameter target at 2" distance .....	90%
Nominal Weight .....	1.2 grams

## INSTALLATION HOLE

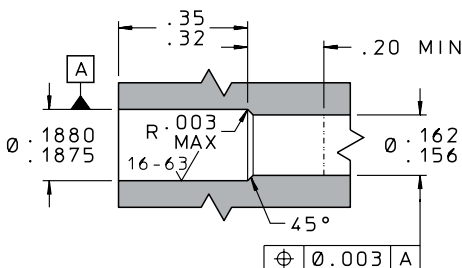

## INSTALLATION AND EXTRACTION

Tool Set Part Number ..... CUTA1870104C

Procedures ..... See **Page N26 – N30**

Replacement Pin Part Number ..... JETA1870003A

*For boss size see **page N24**. For oversize see **page N28**.*

LEE PART NUMBER	LOHM RATE $\pm 10\%$	NOMINAL SCREEN HOLE DIA. (Inches)	REF. FLOW RATE MIL-L-7808 @ 25 psid & 200°F (pph)
JELA1803550L	550	0.015	80
JELA1803750L	750	0.015	60
JELA1803100D	1000	0.008	45
JELA1803130D	1300	0.008	35
JELA1803160D	1600	0.008	30
JELA1803200D	2000	0.008	25

PIN

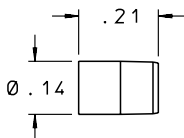

INSERT

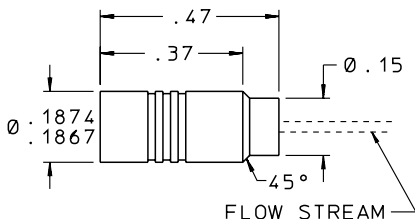

D

MATERIALS		
PART	MATERIAL	SPECIFICATION
Body	303 Cres	QQ-S-763C
Pin	303 Cres	QQ-S-763C
Screen	304L Cres	ASTM A 666
Base Washer	304L Cres	ASTM A 666
Braze	—	AMS 4774

*Finish: All Cres Parts Passivated.*

*Pins are prewaxed. Do not degrease. Do not lubricate.*

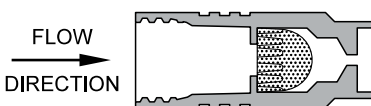

## PERFORMANCE

Lohm Rate Tolerance.....	± 10%
Differential Pressure (Recommended).....	10-200 psid
Flow to hit 0.25" diameter target at 2" distance .....	90%
Nominal Weight .....	1.2 grams

## INSTALLATION HOLE

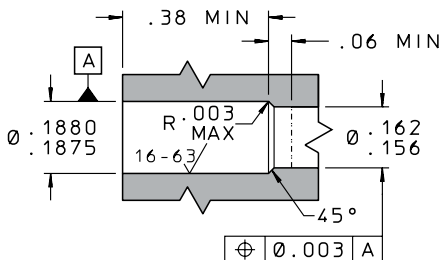

## INSTALLATION AND EXTRACTION

Tool Set Part Number ..... CUTA1870104C

Procedures..... See **Page N26 – N30**

Replacement Pin Part Number ..... JETA1870003A

*For boss size see **page N24**. For oversize see **page N28**.*

LEE PART NUMBER	LOHM RATE ±10%	NOMINAL SCREEN HOLE DIA. (Inches)	REF. FLOW RATE MIL-L-7808 @ 25 psid & 200°F (pph)
JELA1801500L	500	0.015	85
JELA1801900L	900	0.015	50
JELA1801150D	1500	0.008	30
JELA1801250D	2500	0.008	18
JELA1801450D	4500	0.008	10
JELA1801750D	7500	0.006	6

D

PIN

INSERT

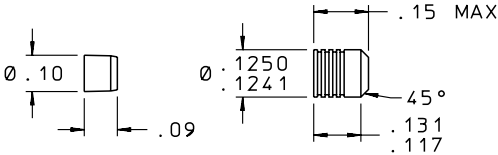

MATERIALS		
PART	MATERIAL	SPECIFICATION
Body	15-5PH Cres	AMS 5659
Pin	15-5PH Cres	AMS 5659

*Finish: All Cres Parts Passivated.  
Pins are prewaxed. Do not degrease. Do not lubricate.*

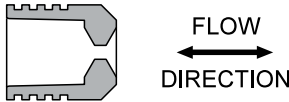

PERFORMANCE	
Lohm Rate Tolerance.....	± 15%
Differential Pressure (Recommended).....	10-200 psi
Maximum Working Pressure.....	1500 psid
Flow to hit 0.25" diameter target at 2" distance.....	90%
Nominal Weight.....	0.18 grams

## INSTALLATION HOLE

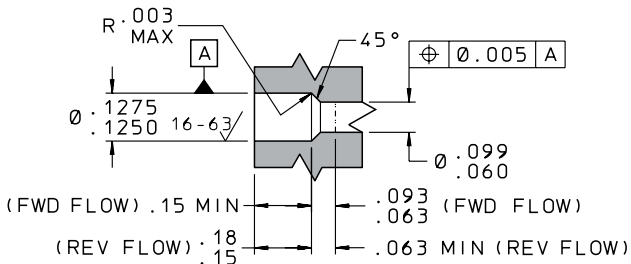

## INSTALLATION AND EXTRACTION

Tool Set Part Number ..... CUTA1250801C

Procedures..... See [Pages N26 – N28](#)

*For boss size see [page N24](#). For oversize see [page N28](#).*

LEE PART NUMBER	LOHM RATE $\pm 15\%$	REFERENCE ORIFICE DIAMETER (Inches)
JELA1210105D	1050	0.029
JELA1210135D	1350	0.025
JELA1210175D	1750	0.022
JELA1210225D	2250	0.019

D

**PIN**

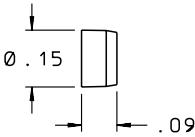

**INSERT**

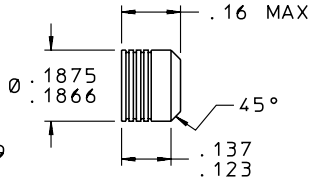

MATERIALS		
PART	MATERIAL	SPECIFICATION
Body	15-5PH Cres	AMS 5659
Pin	15-5PH Cres	AMS 5659

*Finish: All Cres Parts Passivated.*

*Pins are prewaxed. Do not degrease. Do not lubricate.*

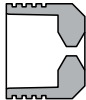

FLOW  
 ←→  
 DIRECTION

PERFORMANCE	
Lohm Rate Tolerance.....	± 15%
Differential Pressure (Recommended).....	10-200 psi
Maximum Working Pressure.....	1500 psid
Flow to hit 0.25" diameter target at 2" distance .....	90%
Nominal Weight .....	0.45 grams

INSTALLATION HOLE

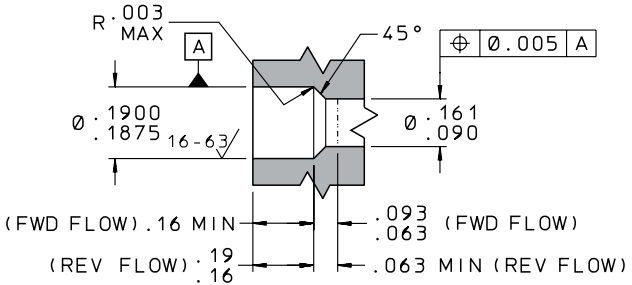

**INSTALLATION AND EXTRACTION**

Tool Set Part Number ..... CUTA1870801C

Procedures..... See **Pages N26 – N28**

*For boss size see **page N24**. For oversize see **page N28**.*

LEE PART NUMBER	LOHM RATE ±15%	REFERENCE ORIFICE DIAMETER (Inches)
JELA1810450L	450	0.045
JELA1810600L	600	0.039
JELA1810800L	800	0.034
JELA1810105D	1050	0.029
JELA1810135D	1350	0.025
JELA1810175D	1750	0.022
JELA1810225D	2250	0.019

D

**PIN**

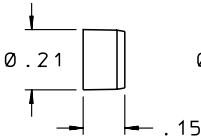

**INSERT**

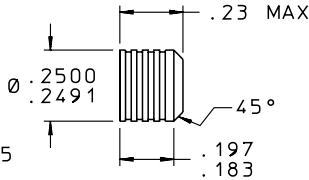

MATERIALS		
PART	MATERIAL	SPECIFICATION
Body	15-5PH Cres	AMS 5659
Pin	15-5PH Cres	AMS 5659

*Finish: All Cres Parts Passivated.*

*Pins are prewaxed. Do not degrease. Do not lubricate.*

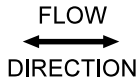
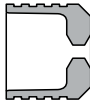

PERFORMANCE	
Lohm Rate Tolerance.....	± 15%
Differential Pressure (Recommended).....	10-200 psi
Maximum Working Pressure.....	1500 psid
Flow to hit 0.25" diameter target at 2" distance.....	90%
Nominal Weight.....	1.2 grams

INSTALLATION HOLE

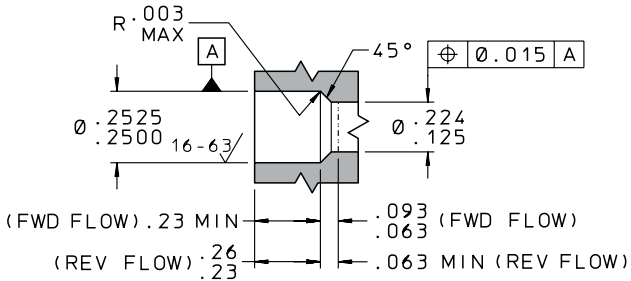

**INSTALLATION AND EXTRACTION**

Tool Set Part Number .....CUTA2500801C

Procedures.....See **Pages N26 – N28**

*For boss size see **page N24**. For oversize see **page N28**.*

LEE PART NUMBER	LOHM RATE ± 15%	REFERENCE ORIFICE DIAMETER (Inches)
JELA2510200L	200	0.070
JELA2510250L	250	0.060
JELA2510350L	350	0.051
JELA2510450L	450	0.045
JELA2510600L	600	0.039
JELA2510800L	800	0.034
JELA2510105D	1050	0.029
JELA2510135D	1350	0.025
JELA2510175D	1750	0.022
JELA2510225D	2250	0.019

D

**PIN**

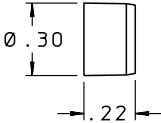

**INSERT**

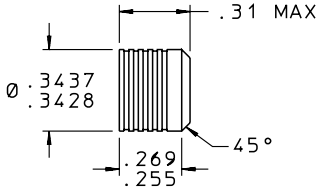



## MATERIALS

PART	MATERIAL	SPECIFICATION
Body	15-5PH Cres	AMS 5659
Pin	15-5PH Cres	AMS 5659

*Finish: All Cres Parts Passivated.*

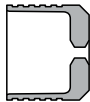
*Pins are prewaxed. Do not degrease. Do not lubricate.*



FLOW  
  
 DIRECTION

## PERFORMANCE

Lohm Rate Tolerance.....	$\pm 15\%$
Differential Pressure (Recommended).....	10-200 psi
Maximum Working Pressure.....	1500 psid
Flow to hit 0.25" diameter target at 2" distance .....	90%
Nominal Weight .....	3.1 grams

INSTALLATION HOLE

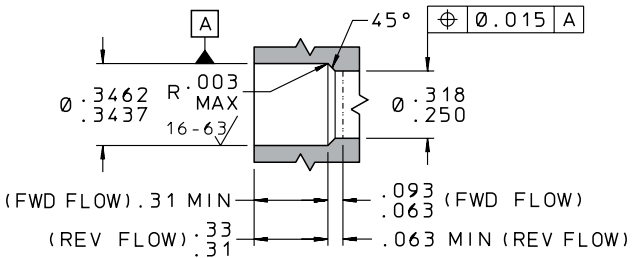

**INSTALLATION AND EXTRACTION**

Tool Set Part Number ..... CUTA3430801C

Procedures..... See **Pages N26 – N28**

*For boss size see **page N24**. For oversize see **page N28**.*

LEE PART NUMBER	LOHM RATE $\pm 15\%$	REFERENCE ORIFICE DIAMETER (Inches)
JELA3410200L	200	0.070
JELA3410250L	250	0.060
JELA3410350L	350	0.051
JELA3410450L	450	0.045
JELA3410600L	600	0.039
JELA3410800L	800	0.034
JELA3410105D	1050	0.029
JELA3410135D	1350	0.025
JELA3410175D	1750	0.022
JELA3410225D	2250	0.019



## **CUSTOM NOZZLE CAPABILITIES**

The Lee Company has developed an extensive range of custom nozzle configurations to enhance the capabilities of the standard product line. Nozzles with unique envelopes are designed to meet customized dimensional and/or performance specifications. Lee Hi-Bar Safety Screens may be integrated directly on the inlet of the nozzle body to create added protection in a extremely robust, one-piece design.

Optimizing the location of lubrication can increase time between maintenance or reduce the weight of a system by eliminating the need for excess lube oil. Standard Lee lube nozzles are tested to ensure the nozzle produces an accurate, solid stream of flow through a target. A number of factors can affect the amount of lubrication that hits a target such as temperature, pressure and fluid. The Lee Company offers custom designs that are optimized to perform under difficult conditions and include custom acceptance testing, including:

- A wide range of test fluids
- Custom flow rates and tolerances
- Multiple targets in a one-piece design
- Test temperatures up to 150°F

# Lee Cheks

E





- Wide range of sizes and flow rates**
- Proven, durable low leakage metal-to-metal seal**
- Integral safety screens optional**
- Soft seat versions for zero leak requirements**
- Pilot Operated configurations available**

## TABLE OF CONTENTS

<b>Ball-Style Cheks</b>	0.187 & 0.250 inch diameter ball style check valves .....3, 8 – 17
<b>Side Exit Cheks</b>	0.093, 0.187 & 0.343 inch diameter side exit check valves.....3, 18 – 25
<b>Lo-Lohm Cheks</b>	0.187, 0.250, 0.375 & 0.500 inch diameter poppet-style check valves .....4, 26 – 37
<b>Hi-Q Cheks</b>	0.50, 0.75, 1.00 inch diameter poppet-style check valves....4, 38 – 45
<b>Zero Leak Cheks</b>	0.187, 0.250, 0.375 & 0.500 inch diameter zero leak poppet-style check valves....4, 46 – 57
<b>High Pressure Cheks</b>	0.125, 0.156, 0.187, 0.250, 0.375 & 0.500 inch diameter high pressure check valves, for 5,000 and 8,000 psi systems.....5, 58 – 77
<b>NACE Compliant High Pressure Cheks</b>	0.125, 0.187, 0.250, 0.375 & 0.500 inch diameter check valves made from NACE Compliant materials ..... 5, 78-79
<b>Pilot Operated Cheks</b>	0.250 inch diameter pilot operated check valves .....5, 80 – 81
<b>High Pressure Pilot Operated Cheks</b>	0.250, 0.375 & 0.500 inch diameter pilot operated check valves for up to 5,000 psi systems.....5, 82 – 87

Lee Cheks are the smallest insert check valves available anywhere in the world. One model is only 3/32 of an inch in diameter and under 1/3 of an inch long. With millions successfully in service, some for over thirty years, Lee Cheks have proven reliability. Every Chek is 100% performance tested before delivery. Lee Cheks set the standard for size, weight, and dependability.

The primary selection criteria for check valves are flow rate, packaging requirements, resistance to contamination, allowable leakage, pressure and temperature requirements and compatibility with the intended fluid and environment. Lee Cheks are available in multiple configurations that include ball-style or poppet-style sealing elements, axial or side-exit flow paths, metal or elastomeric seats, and insert or cartridge style bodies. There are also options for integral safety screens and pilot operated designs.

## **BALL-STYLE LEE CHEKS**

Ball-Style Lee Cheks offer the most economical design with axial flow around a 440C ball that provides the sealing element.

They are designed for 3,000 psi systems, and are available in 0.187 and 0.250 inch diameter envelopes, screened and unscreened, and in forward and reverse flow configurations.

## **SIDE EXIT LEE CHEKS**

Using the side exit porting allows the ball to move out of the flow path, providing increased flow capacity and enhanced silt resistance in a similar package size. Side Exit Lee Cheks are available in 0.093, 0.187 and a 0.343 inch diameter. The ultra miniature 0.093 inch diameter is forward flow only for up to 4,000 psi systems. The 0.187 inch diameter is available screened and unscreened, with forward flow only for 4,000 psi systems. The 0.343 inch diameter is available unscreened, with reverse flow only for 5,000 psi systems.

### **LO-LOHM CHEKS**

Lee Lo-Lohm Cheks are poppet-style, high flow-gain check valves that are wide open at 15 psid and offer the lowest Lohm rate. They come in 0.187, 0.250, 0.375 and 0.500 inch diameters, in both forward and reverse flow directions to meet almost any space requirement. Screens are available on the smallest unit. These miniature all-metal checks are rated for 3,000 psi system pressure (except the 187 size which is rated for 4,000 psi systems).

### **Hi-Q CHEKS**

Lee Hi-Q Chek valves offer the greatest feasible flow capacity for valve cartridges between 1/2 and 1 inch in diameter. The valves feature a unique cage and poppet assembly that maximizes flow capacity at an effectively low cost. A robust design and 100% performance testing ensures consistent, long term performance in 4,000 psi systems.

### **ZERO LEAK CHEKS**

Lee Zero Leak Cheks feature an elastomeric seat material for applications where eliminating leakage is critical. They utilize a poppet-style, axial flow design with a choice of two different elastomers, and are available in 0.187, 0.250, 0.375, 0.500 inch diameters.

### **HIGH PRESSURE CHEKS**

Lee High Pressure Cheks are poppet-style valves for 8,000 psi systems. They are offered in six sizes, starting with the micro-miniature 0.125 inch, up through 0.500 inch. All sizes are available in forward and reverse flow configurations. Screens are available on the 0.125 inch and 0.187 inch diameter sizes.

## **NACE COMPLIANT HIGH PRESSURE CHEKS**

High pressure Lee check valves, designed for the Oil and Gas Industry, are constructed entirely of corrosion-resistant materials that comply with NACE specification MR0175/ISO 15156. They are offered in five diameters from 0.125 up to 0.500 inch. All sizes are available in forward or reverse flow versions and are designed for checked direction pressures up to 15,000 psi.

## **PILOT OPERATED CHEKS**

The Lee Pilot Operated Chek is an all metal, pressure piloted to open, check valve. It is a 0.250 inch diameter, poppet-style valve designed for 3,000 psi systems.

## **HIGH PRESSURE PILOT OPERATED CHEKS**

High pressure pilot to open check valves are designed for system pressures up to 8,000 psi. They are offered in 0.250, 0.375 and 0.500 inch diameters and are available in forward and reverse flow configurations.

TYPE	BODY DIA.	LOHMS	NOMINAL SYSTEM PRESSURE (psi)	SYSTEM PEAK PRESSURE (psi)
Lee Chek Axial Flow	0.187"	u: 400	3000	4050
		u: 400	3000	4050
		s: 460	3000	4050
	0.250"	u: 175	3000	4050
		s: 235	3000	4050
Lee Chek Side Exit	0.093"	u: 700	4000	5400
	0.187"	u: 140 <sup>†</sup>	4000	5400
		s: 150 <sup>†</sup>	4000	5400
	0.343"	u: 30	5000	6750
Lee Zero Leak Chek	0.187"	u: 400	3000	4050
		s: 400	3000	4050
	0.250"	u: 180	3000	4050
	0.375"	u: 45	5000	6750
	0.500"	u: 25	5000	6750
Lee Lo-Lohm Chek	0.187"	u: 100	4000	5400
		s: 140 <sup>††</sup>	4000	5400
	0.250"	u: 50	3000	4050
	0.375"	u: 24	3000	4050
	0.500"	u: 12	3000	4050
Lee Hi-Q Chek	0.500"	u: 14	4000	5400
	0.750"	u: 7.5	4000	5400
	1.000"	u: 3.5	4000	5400

u = unscreened

s = screened

<sup>†</sup> Flow rate limited (See [pages E21 and E23](#))

<sup>††</sup> Flow rate limited for screened, forward flow version (See [pg. E29](#))

TYPE	BODY DIA.	LOHMS	NOMINAL SYSTEM PRESSURE (psi)	SYSTEM PEAK PRESSURE (psi)
Lee High Pressure Chek	0.125"	u: 400	8000	9600
		s: 460	8000	9600
	0.156"	u: 250	5000	6750
		u: 210	8000	9600
	0.187"	s: 250	8000	9600
		u: 60	8000	9600
0.250"	u: 60	8000	9600	
0.375"	u: 27	8000	9600	
0.500"	u: 15	8000	9600	
Lee Pilot Operated Chek	0.250"	u: 300	3000	4050
Lee High Pressure Pilot Operated Chek	0.250"	u: 300	5000	6750
	0.375"	u: 110	5000	6750
	0.500"	u: 60	5000	6750
Lee NACE Compliant High Pressure Chek	0.125"	u: 400	15,000	15,000
	0.187"	u: 210	15,000	15,000
	0.250"	u: 60	15,000	15,000
	0.375"	u: 27	15,000	15,000
	0.500"	u: 15	15,000	15,000

PIN

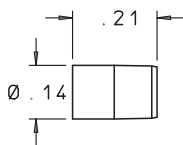

INSERT

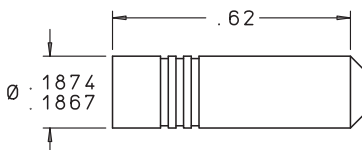

## MATERIALS

PART	MATERIAL	SPECIFICATION
Body	303 Cres	QQ-S-763C
Pin	303 Cres	QQ-S-763C
Spring	17-7PH Cres	AMS 5678
Ball	440C Cres	AMS 5630
Ball Follower	303 Cres	QQ-S-763C
Spring Seat	303 Cres	QQ-S-763C
Cage	303 Cres	QQ-S-763C

*Finish: All Cres Parts Passivated.*

*Pins are prewaxed. Do not degrease. Do not lubricate.*

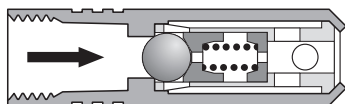

**CKFA1876005A • FREE FLOW FORWARD**

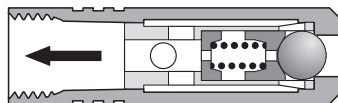

**CKRA1876005A • FREE FLOW REVERSE**

LEE PART NUMBER	CRACKING PRESSURE (psid)	LOHM RATE	FLOW DIRECTION
CKFA1876005A	5 ± 3	400	FORWARD
CKFA1871001A	1 ± 0.5	400	FORWARD
CKRA1876005A	5 ± 3	400	REVERSE
CKRA1871001A	1 ± 0.5	400	REVERSE

## INSTALLATION HOLE

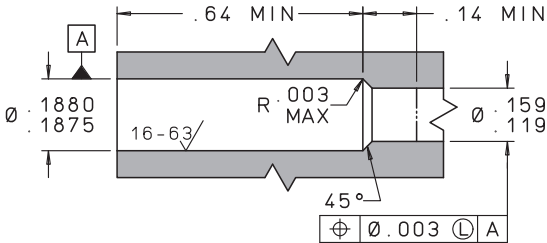

## INSTALLATION AND EXTRACTION

Tool Set Part Number ..... CUTA1870104C  
 Procedures ..... See [Pages N26 – N30](#)  
 Line Mount Configurations..... See [Pages L6 – L8](#)  
 Replacement Pin Part Number..... JETA1870003A  
*For boss size see [page N24](#). For oversize see [page N28](#).*

## PERFORMANCE

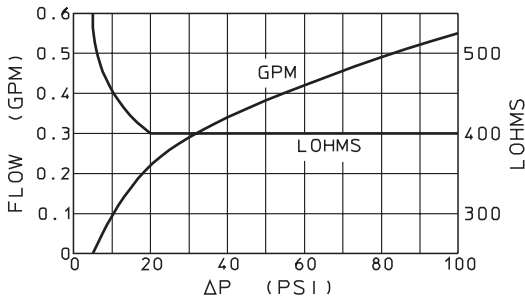

Cracking Pressure .....  $5 \pm 3$  or  $1 \pm 0.5$  psid  
 Maximum Leakage in ..... 1 drop/minute at 5 psid  
     checked direction ..... 1 drop/hour at 1000 - 3000 psid  
 Lohm rate at 20 psid and greater..... 400 Lohms Maximum  
 Nominal System Pressure ..... up to 3000 psi  
 Nominal Weight ..... 1.5 grams  
*Valve performance on MIL-PRF-83282 at 85°F. 1 drop = 50  $\mu$ L*

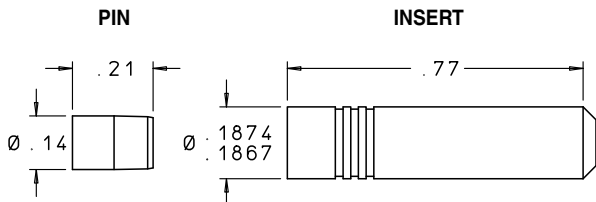

### MATERIALS

PART	MATERIAL	SPECIFICATION
Body	303 Cres	QQ-S-763C
Pin	303 Cres	QQ-S-763C
Spring	17-7PH Cres	AMS 5678
Ball	440C Cres	AMS 5630
Ball Follower	303 Cres	QQ-S-763C
Spring Seat	303 Cres	QQ-S-763C
Cage	303 Cres	QQ-S-763C
Screen	304L Cres	ASTM A 666
Braze	—	AMS 4774

*Finish: All Cres Parts Passivated.*

*Pins are prewaxed. Do not degrease. Do not lubricate.*

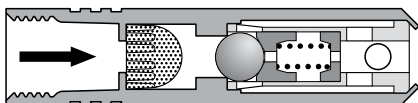

**CKFA1875005A • FREE FLOW FORWARD**

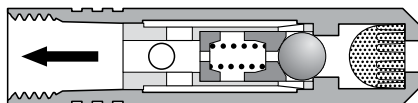

**CKRA1875005A • FREE FLOW REVERSE**

LEE PART NUMBER	CRACKING PRESSURE (psid)	LOHM RATE	SCREEN HOLE SIZE (Inches)	FLOW DIRECTION
CKFA1875005A	5 ± 3	460	0.008	FORWARD
CKFA1875001A	1 ± 0.5	460	0.008	FORWARD
CKRA1875005A	5 ± 3	460	0.008	REVERSE
CKRA1875001A	1 ± 0.5	460	0.008	REVERSE

**INSTALLATION HOLE**

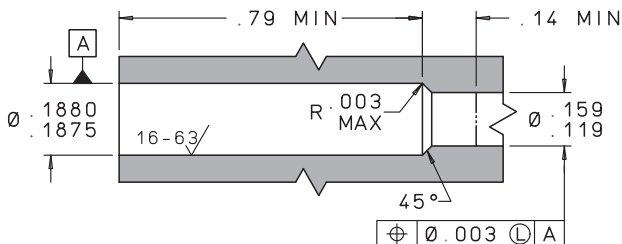

**INSTALLATION AND EXTRACTION**

Tool Set Part Number ..... CUTA1870104C

Procedures ..... See **Pages N26 – N30**

Line Mount Configurations..... See **Pages L6 – L8**

Replacement Pin Part Number..... JETA1870003A

*For boss size see **page N24**. For oversize see **page N28**.*

**PERFORMANCE**

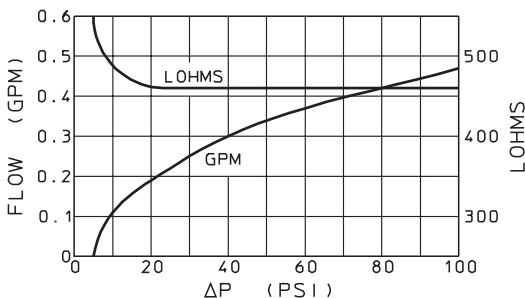

Cracking Pressure .....  $5 \pm 3$  or  $1 \pm 0.5$  psid

Maximum Leakage in ..... 1 drop/minute at 5 psid

checked direction ..... 1 drop/hour at 1000 - 3000 psid

Lohm rate at 20 psid and greater..... 460 Lohms Maximum

Nominal System Pressure ..... up to 3000 psi

Nominal Weight ..... 2.3 grams

*Valve performance on MIL-PRF-83282 at 85°F. 1 drop = 50  $\mu$ L*

PIN

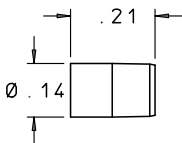

INSERT

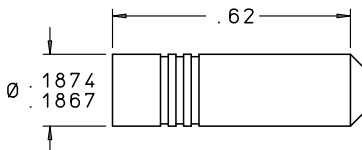

## MATERIALS

PART	MATERIAL	SPECIFICATION
Body	303 Cres	QQ-S-763C
Pin	17-4PH Cres	AMS 5643
Spring	17-7PH Cres	AMS 5678
Ball	440C Cres	AMS 5630
Ball Follower	303 Cres	QQ-S-763C
Spring Seat	303 Cres	QQ-S-763C
Cage	303 Cres	QQ-S-763C

*Finish: All Cres Parts Passivated.*

*Pins are prewaxed. Do not degrease. Do not lubricate.*

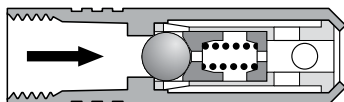

CKFA1876105A • FREE FLOW FORWARD

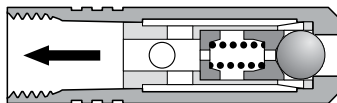

CKRA1876105A • FREE FLOW REVERSE

LEE PART NUMBER	CRACKING PRESSURE (psid)	LOHM RATE	FLOW DIRECTION
CKFA1876105A	5 ± 3	250	FORWARD
CKFA1876101A	1 ± 0.5	250	FORWARD
CKRA1876105A	5 ± 3	250	REVERSE
CKRA1876101A	1 ± 0.5	250	REVERSE

### INSTALLATION HOLE

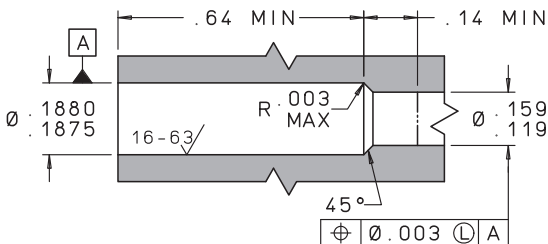

### INSTALLATION AND EXTRACTION

Tool Set Part Number ..... CUTA1870104C  
 Procedures ..... See **Pages N26 – N30**  
 Line Mount Configurations..... See **Pages L6 – L8**  
 Replacement Pin Part Number..... JETA1870004A  
 For boss size see **page N24**. For oversize see **page N28**.

### PERFORMANCE

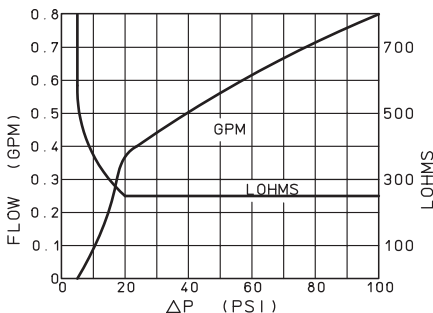

Cracking Pressure .....  $5 \pm 3$  or  $1 \pm 0.5$  psid  
 Maximum Leakage in ..... 1 drop/minute at 5 psid  
     checked direction         1 drop/hour at 1000 - 3000 psid  
 Lohm rate at 20 psid and greater..... 250 Lohms Maximum  
 Nominal System Pressure ..... up to 3000 psi  
 Nominal Weight ..... 1.5 grams  
 Valve performance on MIL-PRF-83282 at 85°F. 1 drop = 50  $\mu$ L

PIN

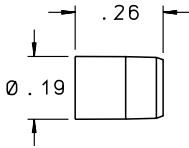

INSERT

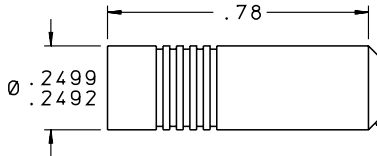

## MATERIALS

PART	MATERIAL	SPECIFICATION
Body	303 Cres	QQ-S-763C
Pin	303 Cres	QQ-S-763C
Spring	17-7PH Cres	AMS 5678
Ball	440C Cres	AMS 5630
Ball Follower	303 Cres	QQ-S-763C
Spring Seat	303 Cres	QQ-S-763C
Cage	303 Cres	QQ-S-763C

Finish: All Cres Parts Passivated.

Pins are prewaxed. Do not degrease. Do not lubricate.

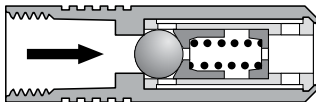

CKFA2506005A • FREE FLOW FORWARD

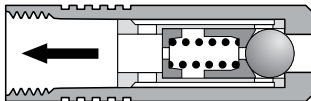

CKRA2506005A • FREE FLOW REVERSE

LEE PART NUMBER	CRACKING PRESSURE (psid)	LOHM RATE	FLOW DIRECTION
CKFA2506005A	5 ± 3	175	FORWARD
CKFA2501001A	1 ± 0.5	175	FORWARD
CKRA2506005A	5 ± 3	175	REVERSE
CKRA2501001A	1 ± 0.5	175	REVERSE

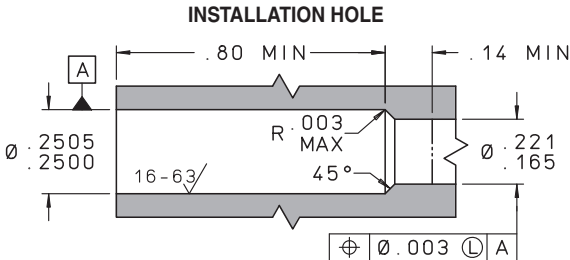

## INSTALLATION AND EXTRACTION

Tool Set Part Number ..... CUTA2500106C  
 Procedures ..... See **Pages N26 – N30**  
 Line Mount Configurations..... See **Pages L9 – L12**  
 Replacement Pin Part Number..... CKFA2500003A  
*For boss size see **page N24**. For oversize see **page N28**.*

## PERFORMANCE

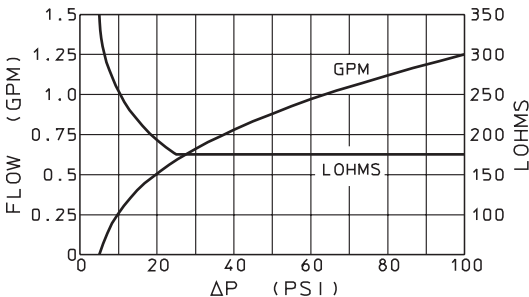

Cracking Pressure .....  $5 \pm 3$  or  $1 \pm 0.5$  psid  
 Maximum Leakage in ..... 1 drop/minute at 5 psid  
     checked direction      1 drop/hour at 1000 - 3000 psid  
 Lohm rate at 25 psid and greater..... 175 Lohms Maximum  
 Nominal System Pressure ..... up to 3000 psi  
 Nominal Weight ..... 3.8 grams  
 Valve performance on MIL-PRF-83282 at 85°F. 1 drop = 50  $\mu\text{L}$

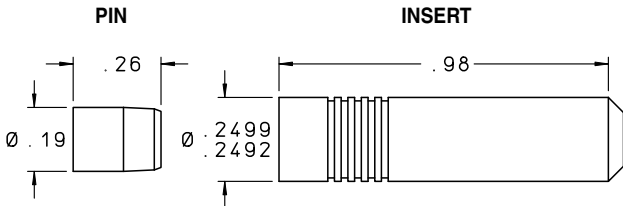

### MATERIALS

PART	MATERIAL	SPECIFICATION
Body	303 Cres	QQ-S-763C
Pin	303 Cres	QQ-S-763C
Spring	17-7PH Cres	AMS 5678
Ball	440C Cres	AMS 5630
Ball Follower	303 Cres	QQ-S-763C
Spring Seat	303 Cres	QQ-S-763C
Cage	303 Cres	QQ-S-763C
Screen	304L Cres	ASTM A 666
Braze	—	AMS 4774

Finish: All Cres Parts Passivated.

Pins are prewaxed. Do not degrease. Do not lubricate.

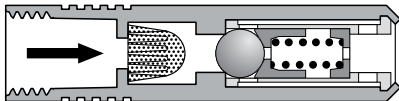

CKFA2505005A • FREE FLOW FORWARD

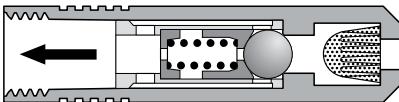

CKRA2505005A • FREE FLOW REVERSE

LEE PART NUMBER	CRACKING PRESSURE (psid)	LOHM RATE	SCREEN HOLE SIZE (Inches)	FLOW DIRECTION
CKFA2505005A	5 ± 3	235	0.008	FORWARD
CKFA2505001A	1 ± 0.5	235	0.008	FORWARD
CKRA2505005A	5 ± 3	235	0.008	REVERSE
CKRA2505001A	1 ± 0.5	235	0.008	REVERSE

## INSTALLATION HOLE

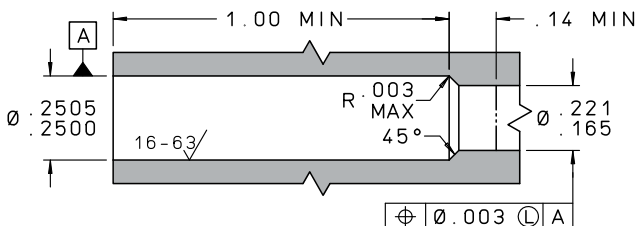

## INSTALLATION AND EXTRACTION

Tool Set Part Number ..... CUTA2500106C  
 Procedures ..... See [Pages N26 – N30](#)  
 Line Mount Configurations..... See [Pages L9 – L12](#)  
 Replacement Pin Part Number..... CKFA2500003A  
*For boss size see [page N24](#). For oversize see [page N28](#).*

## PERFORMANCE

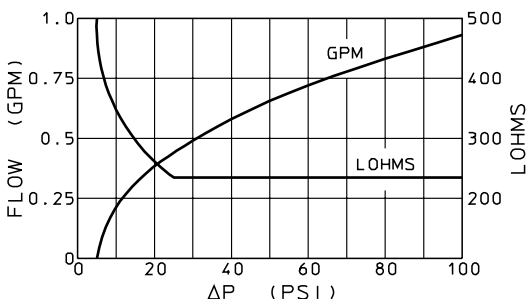

Cracking Pressure .....  $5 \pm 3$  or  $1 \pm 0.5$  psid  
 Maximum Leakage in ..... 1 drop/minute at 5 psid  
     checked direction ..... 1 drop/hour at 1000 - 3000 psid  
 Lohm rate at 25 psid and greater..... 235 Lohms Maximum  
 Nominal System Pressure ..... up to 3000 psi  
 Nominal Weight ..... 4.5 grams  
*Valve performance on MIL-PRF-83282 at 85°F. 1 drop = 50  $\mu$ L*

PIN

INSERT

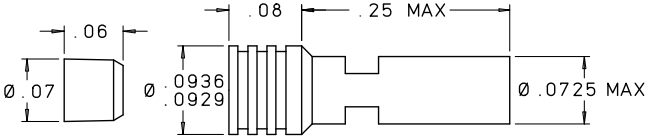

E

## MATERIALS

PART	MATERIAL	SPECIFICATION
Body	15-5PH Cres	AMS 5659
Pin	13-8 MO Cres	AMS 5629
Spring	17-7PH Cres	AMS 5678
Ball	440C Cres	AMS 5630
Ball Follower	15-5PH Cres	AMS 5659
Spring Seat	15-5PH Cres	AMS 5659

*Finish: All Cres Parts Passivated.*

*Pins are prewaxed. Do not degrease. Do not lubricate.*

## FREE FLOW FORWARD

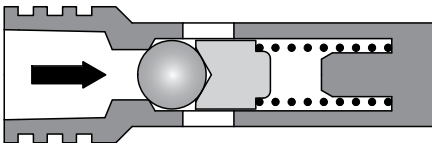

LEE PART NUMBER	CRACKING PRESSURE (psid)	LOHM RATE (max.)	FLOW DIRECTION
CKFA0936015A	5 ± 3	700	FORWARD

INSTALLATION HOLE

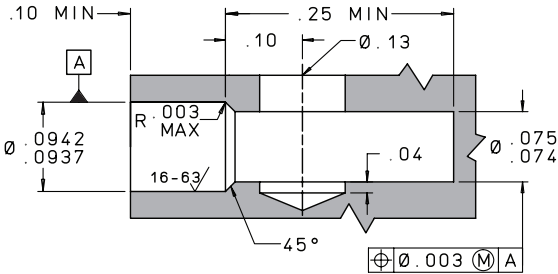

INSTALLATION AND EXTRACTION

Tool Set Part Number ..... CUTA0930106C  
 Procedures ..... See **Pages N26 – N30**  
*For boss size see **page N24**. For oversize see **page N28**.*

PERFORMANCE

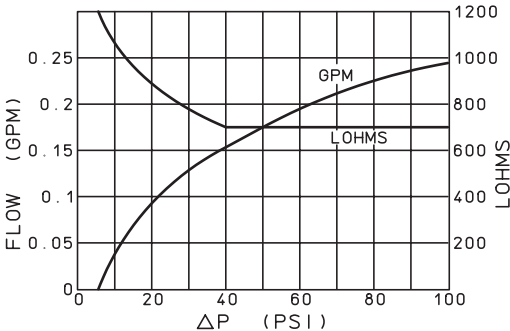

Cracking Pressure .....  $5 \pm 3$   
 Maximum Leakage in checked direction ... 1 drop/minute at 5 psid  
 ..... 1 drop/hour at 1000 - 4000 psid  
 Lohm rate at 25 psid and greater ..... 700 Lohms Maximum  
 Nominal System Pressure ..... up to 4000 psi  
 Nominal Weight ..... 0.14 grams  
*Valve performance on MIL-PRF-83282 at 85°F. 1 drop = 50  $\mu$ L*

PIN

INSERT

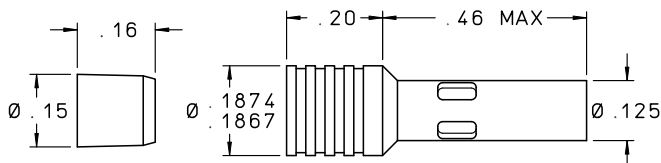

E

## MATERIALS

PART	MATERIAL	SPECIFICATION
Body	17-4PH Cres	AMS 5643
Pin	17-4PH Cres	AMS 5643
Spring Seat	17-4PH Cres	AMS 5643
Spring Guide	304 Cres	AMS 5639
Ball Follower	304 Cres	AMS 5639
Ball	440C Cres	AMS 5630
Spring	17-7PH Cres	AMS 5678

*Finish: All Cres Parts Passivated.*

*Pins are prewaxed. Do not degrease. Do not lubricate.*

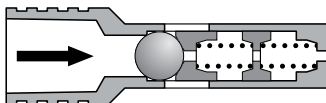

**CKFA1876015A • FREE FLOW FORWARD**

LEE PART NUMBER	CRACKING PRESSURE (psid)	LOHM RATE	FLOW DIRECTION
CKFA1876015A	5 ± 3	140	FORWARD

### INSTALLATION HOLE

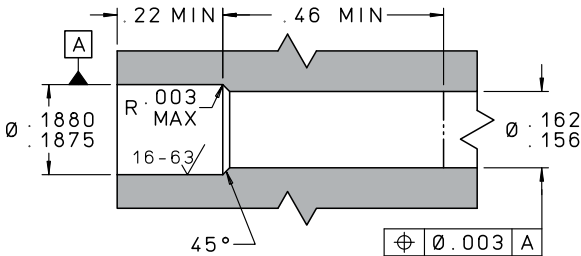

### INSTALLATION AND EXTRACTION

Tool Set Part Number ..... CUTA1870306C  
 Procedures ..... See **Pages N26 – N30**  
 Replacement Pin Part Number..... CKFA1870004A  
*For boss size see **page N24**. For oversize see **page N28**.*

### PERFORMANCE

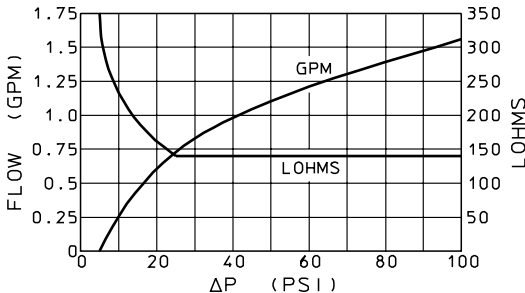

Cracking Pressure ..... 5 ± 3 psid  
 Maximum Leakage in ..... 1 drop/minute at 5 psid  
     checked direction ..... 1 drop/hour at 1000 - 4000 psid  
 Lohm rate at 25 psid and greater ..... 140 Lohms Maximum  
 Maximum Flow Rate ..... 6 GPM  
 Nominal System Pressure..... up to 4000 psi  
 Nominal Weight ..... 1.0 grams  
*Valve performance on MIL-PRF-83282 at 85°F. 1 drop = 50 μL*

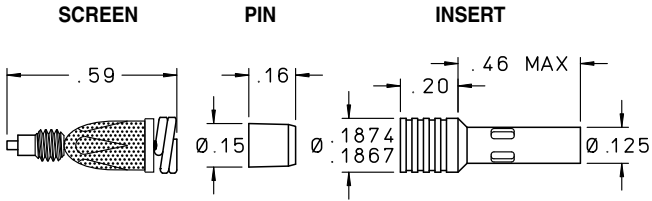

### MATERIALS

PART	MATERIAL	SPECIFICATION
Body	17-4PH Cres	AMS 5643
Pin	17-4PH Cres	AMS 5643
Spring Seat	17-4PH Cres	AMS 5643
Spring Guide	304 Cres	AMS 5639
Ball Follower	304 Cres	AMS 5639
Ball	440C Cres	AMS 5630
Springs	17-7PH Cres	AMS 5678
Screen	304L Cres	ASTM A 666
Braze	—	AMS 4774
Post	303 Cres	QQ-S-763C

Finish: All Cres Parts Passivated.

Pins are prewaxed. Do not degrease. Do not lubricate.

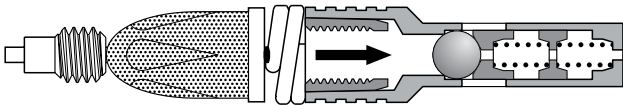

### CKFA1875035A • FREE FLOW FORWARD

LEE PART NUMBER	CRACKING PRESSURE (psid)	LOHM RATE	SCREEN HOLE SIZE (Inches)	FLOW DIRECTION	MAX. FLOW RATE (GPM)
CKFA1875035A	5 ± 3	150	0.004	FORWARD	4
CKFA1875045A	5 ± 3	150	0.006	FORWARD	6
CKFA1875055A	5 ± 3	150	0.008	FORWARD	6
CKFA1875065A	5 ± 3	150	0.015	FORWARD	6

Note: For additional screen information see [page 173](#).

### INSTALLATION HOLE

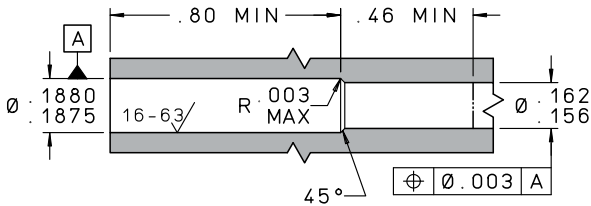

### INSTALLATION AND EXTRACTION

Tool Set Part Number

Insert ..... CUTA1870306C

Screen ..... CUTA1870228C

Procedures ..... See [Pages N26 – N30](#)

Replacement Pin Part Number ..... CKFA1870004A

*For boss size see [page N24](#). For oversize see [page N28](#).*

E

### PERFORMANCE

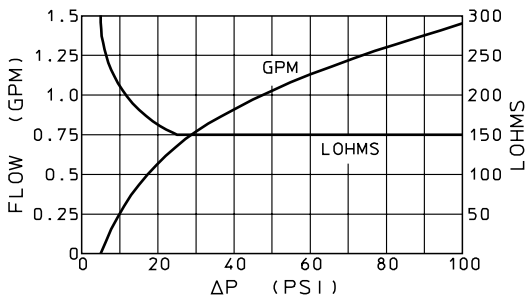

Cracking Pressure .....  $5 \pm 3$  psid

Maximum Leakage in ..... 1 drop/minute at 5 psid

checked direction ..... 1 drop/hour at 1000 - 4000 psid

Lohm rate at 25 psid and greater.... 150 Lohms Maximum

Nominal System Pressure..... up to 4000 psi

Nominal Weight ..... 1.5 grams

*Valve performance on MIL-PRF-83282 at 85°F. 1 drop = 50  $\mu$ L*

PIN

PLUG

INSERT

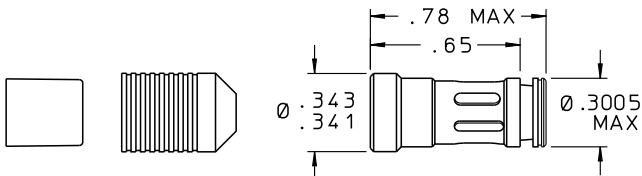

E

## MATERIALS

PART	MATERIAL	SPECIFICATION
Body Rear	303 Cres	QQ-S-763C
Body Front	15-5PH Cres	AMS 5659
Spring	17-7PH Cres	AMS 5078
Poppet	15-5PH Cres	AMS 5659
Nose Seal	6061-T6 AL	AMS 4117

Finish: All Cres Parts Passivated.

NOTE: .343 diameter Lee Pin/Plug Set sold separately, see Section A

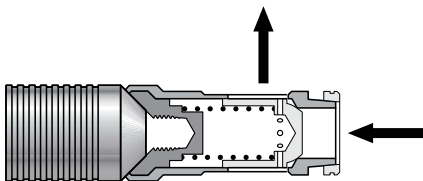

CHRA3436305A • FREE FLOW REVERSE

LEE PART NUMBER	CRACKING PRESSURE (psid)	LOHM RATE	FLOW DIRECTION
CHRA3436305A	$5 \pm 3$	30	REVERSE

## INSTALLATION HOLE

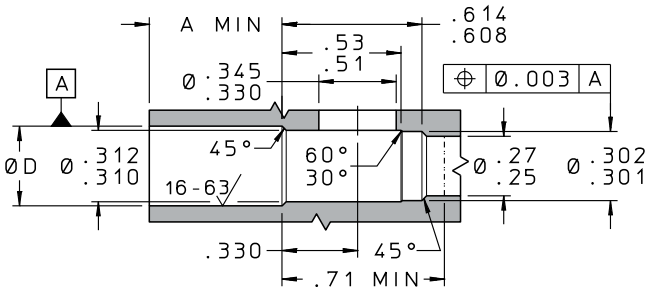

## INSTALLATION AND EXTRACTION

Tool Set Part Number ..... CUTA3430106C  
 Procedures ..... See **Pages N26 – N30**  
 Replacement Nose Seal Part Number ..... CHRA3430009A  
*For boss size see **page N24**. For oversize see **page N28**.*

## PERFORMANCE

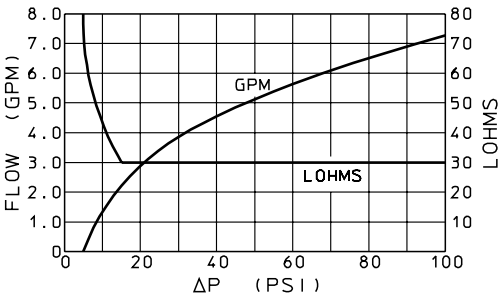

Cracking Pressure .....  $5 \pm 3$  psid  
 Maximum Leakage in ..... 1 drop/minute at 5 psid  
     checked direction ..... 1 drop/hour at 1000 - 5000 psid  
 Lohm rate at 15 psid and greater ..... 30 Lohms Maximum  
 Nominal System Pressure ..... up to 5000 psi  
 Nominal Weight ..... 3.6 grams (Insert only)  
*Valve performance on MIL-PRF-83282 at 85°F. 1 drop = 50  $\mu$ L*

PIN

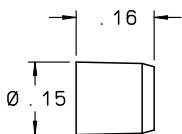

INSERT

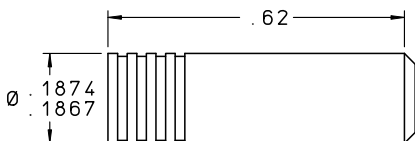

### MATERIALS

PART	MATERIAL	SPECIFICATION
Body	304 Cres	AMS 5639
Pin	17-4PH Cres	AMS 5643
Poppet	15-5PH Cres	AMS 5659
Spring	17-7PH Cres	AMS 5678
Spring Seat	304 Cres	AMS 5639

*Finish: All Cres Parts Passivated.*

*Pins are prewaxed. Do not degrease. Do not lubricate.*

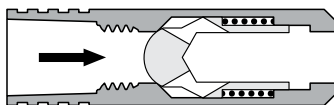

**CKFA1876205A • FREE FLOW FORWARD**

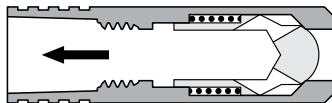

**CKRA1876205A • FREE FLOW REVERSE**

LEE PART NUMBER	CRACKING PRESSURE (psid)	LOHM RATE	FLOW DIRECTION
CKFA1876205A	5 ± 3	100	FORWARD
CKFA1876201A	1 ± 0.5	100	FORWARD
CKRA1876205A	5 ± 3	100	REVERSE
CKRA1876201A	1 ± 0.5	100	REVERSE

## INSTALLATION HOLE

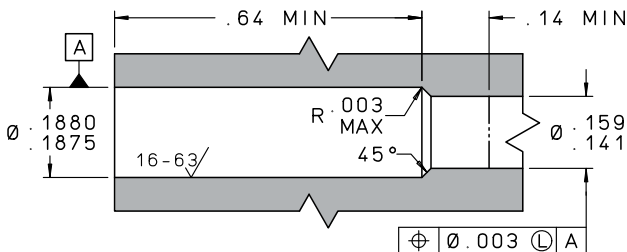

## INSTALLATION AND EXTRACTION

Tool Set Part Number ..... CUTA1870110C  
 Procedures ..... See **Pages N26 – N30**  
 Line Mount Configurations..... See **Pages L6 – L8**  
 Replacement Pin Part Number..... CKFA1870005A  
*For boss size see **page N24**. For oversize see **page N28**.*

## PERFORMANCE

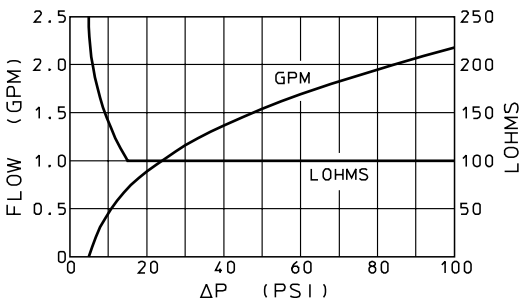

Cracking Pressure .....  $5 \pm 3$  or  $1 \pm 0.5$  psid  
 Maximum Leakage in ..... 1 drop/minute at 5 psid  
     checked direction ..... 1 drop/hour at 1000 - 4000 psid  
 Lohm rate at 15 psid and greater..... 100 Lohms Maximum  
 Nominal System Pressure ..... up to 4000 psi  
 Nominal Weight ..... 1.4 grams  
*Valve performance on MIL-PRF-83282 at 85°F. 1 drop = 50  $\mu$ L*

SCREEN

PIN

INSERT

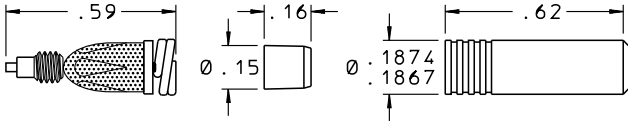

E

**MATERIALS**

PART	MATERIAL	SPECIFICATION
Body	304 Cres	AMS 5639
Pin	17-4PH Cres	AMS 5643
Poppet	15-5PH Cres	AMS 5659
Springs	17-7PH Cres	AMS 5678
Spring Seat	304 Cres	AMS 5639
Screen	304L Cres	ASTM A 666
Braze	—	AMS 4774
Post	303 Cres	QQ-S-763C

*Finish: All Cres Parts Passivated.*

*Pins are prewaxed. Do not degrease. Do not lubricate.*

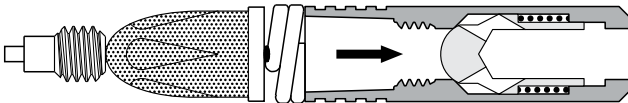
**CKFA1875205A • FREE FLOW FORWARD**

LEE PART NUMBER	CRACKING PRESSURE (psid)	LOHM RATE	SCREEN HOLE SIZE (Inches)	FLOW DIRECTION
CKFA1875205A	5 ± 3	140	0.015	FORWARD
CKFA1875201A	1 ± 0.5	140	0.015	FORWARD

*Note: For additional screen information see [page I73](#).*

### INSTALLATION HOLE

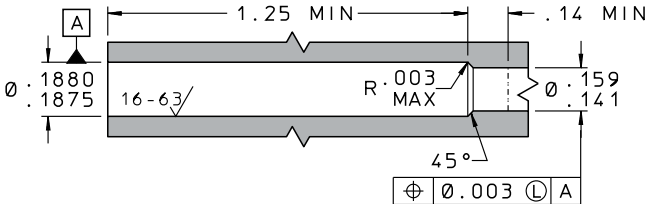

### INSTALLATION AND EXTRACTION

Tool Set Part Number: Insert..... CUTA1870110C  
 Screen..... CUTA1870228C  
 Installation/Extraction Procedures ..... See **Pages N26 – N30**  
 Replacement Pin Part Number..... CKFA1870005A  
 Replacement Screen Part Number..... FSSA1870150B

*For boss size see [page N24](#). For oversize see [page N28](#).*

### PERFORMANCE

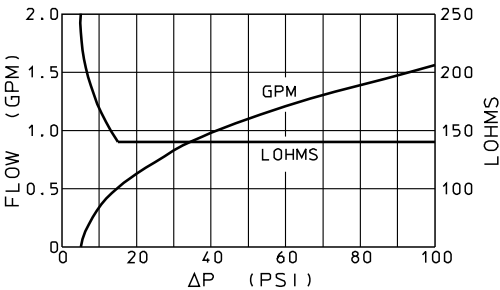

Cracking Pressure.....  $5 \pm 3$  or  $1 \pm 0.5$  psid  
 Maximum Leakage in ..... 1 drop/minute at 5 psid  
     checked direction      1 drop/hour at 1000 - 4000 psid  
 Lohm rate at 15 psid and greater ... 140 Lohms Maximum  
 Maximum Flow Rate ..... 8 GPM  
 Nom. Screen Hole Size..... .015 Inch  
 Nominal System Pressure..... up to 4000 psi  
 Nominal Weight..... 1.8 grams  
*Valve performance on MIL-PRF-83282 at 85 °F. 1 drop = 50  $\mu$ L*

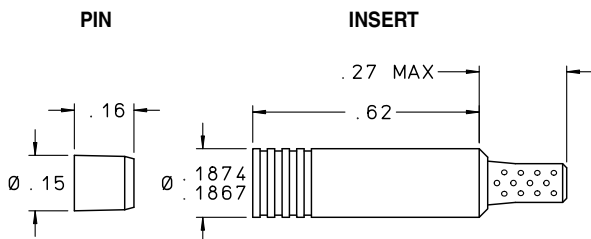

## E

## MATERIALS

PART	MATERIAL	SPECIFICATION
Body	304 Cres	AMS 5639
Pin	17-4PH Cres	AMS 5643
Poppet	15-5PH Cres	AMS 5659
Spring	17-7PH Cres	AMS 5678
Screen	303 Cres	QQ-S-763C
Spring Seat	304 Cres	AMS 5639

*Finish: All Cres Parts Passivated.*

*Pins are prewaxed. Do not degrease. Do not lubricate.*

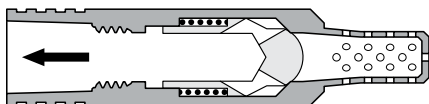

## CKRA1875205A • FREE FLOW REVERSE

LEE PART NUMBER	CRACKING PRESSURE (psid)	LOHM RATE	SCREEN HOLE SIZE (Inches)	FLOW DIRECTION
CKRA1875205A	5 ± 3	140	0.015	REVERSE
CKRA1875201A	1 ± 0.5	140	0.015	REVERSE

## INSTALLATION HOLE

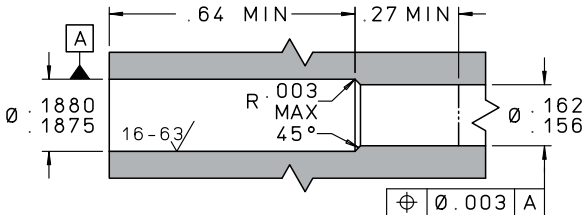

## INSTALLATION AND EXTRACTION

Tool Set Part Number ..... CUTA1870110C  
 Procedures ..... See [Pages N26 – N30](#)  
 Line Mount Configurations..... See [Pages L6 – L8](#)  
 Replacement Pin Part Number..... CKFA1870005A

*For boss size see [page N24](#). For oversize see [page N28](#).*

## PERFORMANCE

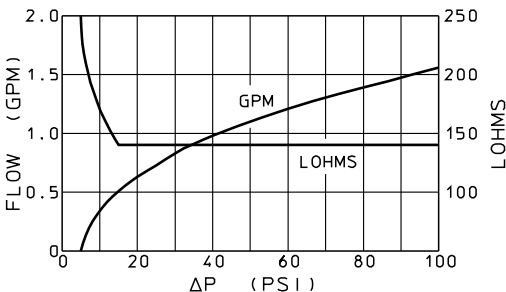

Cracking Pressure .....  $5 \pm 3$  or  $1 \pm 0.5$  psid  
 Maximum Leakage in ..... 1 drop/minute at 5 psid  
     checked direction         1 drop/hour at 1000 - 4000 psid  
 Lohm rate at 15 psid and greater..... 140 Lohms Maximum  
 Nominal System Pressure ..... up to 4000 psi  
 Nominal Weight ..... 1.55 grams  
*Valve performance on MIL-PRF-83282 at 85°F. 1 drop = 50  $\mu$ L*

PIN

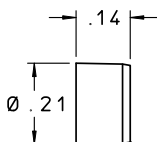

INSERT

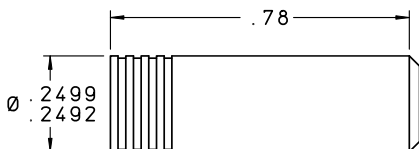

### MATERIALS

PART	MATERIAL	SPECIFICATION
Body	304 Cres	AMS 5639
Pin	17-4PH Cres	AMS 5643
Poppet	15-5PH Cres	AMS 5659
Spring	17-7PH Cres	AMS 5678
Spring Seat	304 Cres	AMS 5639

*Finish: All Cres Parts Passivated.*

*Pins are prewaxed. Do not degrease. Do not lubricate.*

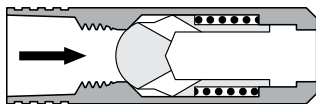

**CKFA2506205A • FREE FLOW FORWARD**

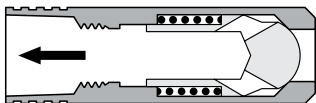

**CKRA2506205A • FREE FLOW REVERSE**

LEE PART NUMBER	CRACKING PRESSURE (psid)	LOHM RATE	FLOW DIRECTION
CKFA2506205A	5 ± 3	50	FORWARD
CKFA2506201A	1 ± 0.5	50	FORWARD
CKRA2506205A	5 ± 3	50	REVERSE
CKRA2506201A	1 ± 0.5	50	REVERSE

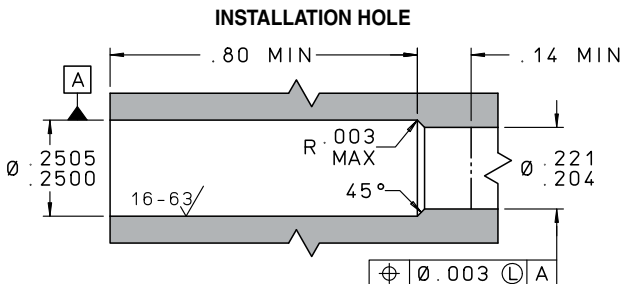

## INSTALLATION AND EXTRACTION

Tool Set Part Number ..... CUTA2500306C  
 Procedures ..... See [Pages N26 – N30](#)  
 Line Mount Configurations..... See [Pages L9 – L12, L34 – L45](#)  
 Replacement Pin Part Number ..... CKFA2500005A  
*For boss size see [page N24](#). For oversize see [page N28](#).*

## PERFORMANCE

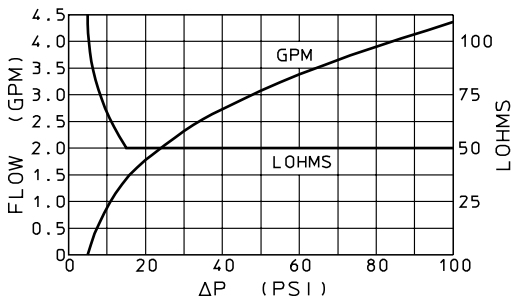

Cracking Pressure .....  $5 \pm 3$  or  $1 \pm 0.5$  psid  
 Maximum Leakage in ..... 1 drop/minute at 5 psid  
     checked direction         1 drop/hour at 1000 - 3000 psid  
 Lohm rate at 15 psid and greater..... 50 Lohms Maximum  
 Nominal System Pressure ..... up to 3000 psi  
 Nominal Weight ..... 3.8 grams  
*Valve performance on MIL-PRF-83282 at 85°F. 1 drop = 50  $\mu\text{L}$*

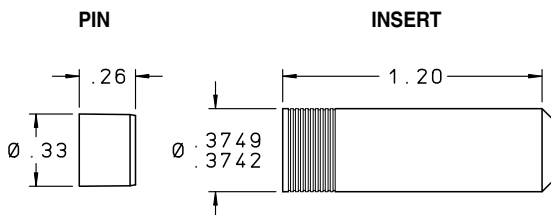

### MATERIALS

PART	MATERIAL	SPECIFICATION
Body	304 Cres	AMS 5639
Pin	17-4PH Cres	AMS 5643
Poppet	15-5PH Cres	AMS 5659
Spring Seat	304 Cres	AMS 5639
Spring	17-7PH Cres	AMS 5678

*Finish: All Cres Parts Passivated.*

*Pins are prewaxed. Do not degrease. Do not lubricate.*

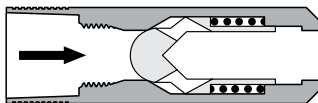

**CKFA3756205A • FREE FLOW FORWARD**

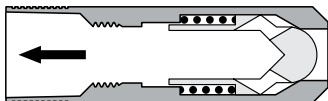

**CKRA3756205A • FREE FLOW REVERSE**

LEE PART NUMBER	CRACKING PRESSURE (psid)	LOHM RATE	FLOW DIRECTION
CKFA3756205A	5 ± 3	24	FORWARD
CKFA3756201A	1 ± 0.5	24	FORWARD
CKRA3756205A	5 ± 3	24	REVERSE
CKRA3756201A	1 ± 0.5	24	REVERSE

## INSTALLATION HOLE

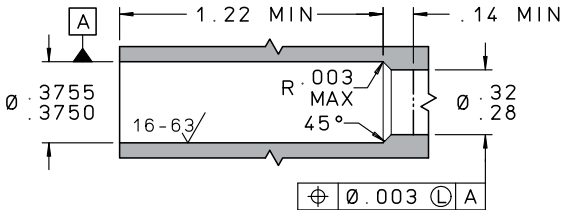

## INSTALLATION AND EXTRACTION

Tool Set Part Number ..... CUTA3750106C  
 Procedures ..... See [Pages N26 – N30](#)  
 Line Mount Configurations..... See [Pages L34 – L45](#)  
 Replacement Pin Part Number..... CKFA3750003A  
*For boss size see [page N24](#). For oversize see [page N28](#).*

## PERFORMANCE

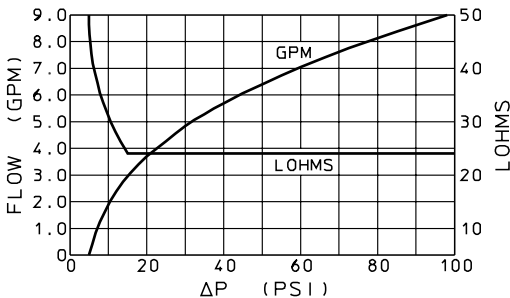

Cracking Pressure .....  $5 \pm 3$  or  $1 \pm 0.5$  psid  
 Maximum Leakage in ..... 1 drop/minute at 5 psid  
     checked direction ..... 1 drop/hour at 1000 - 3000 psid  
 Lohm rate at 15 psid and greater..... 24 Lohms Maximum  
 Nominal System Pressure ..... up to 3000 psi  
 Nominal Weight ..... 9.0 grams  
*Valve performance on MIL-PRF-83282 at 85°F. 1 drop = 50  $\mu$ L*

PIN

INSERT

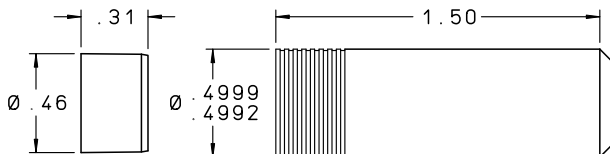

### MATERIALS

PART	MATERIAL	SPECIFICATION
Body	304 Cres	AMS 5639
Pin	15-5PH Cres	AMS 5659
Poppet	15-5PH Cres	AMS 5659
Spring Seat	303 Cres	QQ-S-763C
Spring	17-7PH Cres	AMS 5678

*Finish: All Cres Parts Passivated.*

*Pins are prewaxed. Do not degrease. Do not lubricate.*

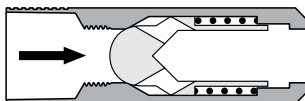

**CKFA5006205A • FREE FLOW FORWARD**

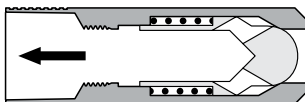

**CKRA5006205A • FREE FLOW REVERSE**

LEE PART NUMBER	CRACKING PRESSURE (psid)	LOHM RATE	FLOW DIRECTION
CKFA5006205A	5 ± 3	12	FORWARD
CKFA5006201A	1 ± 0.5	12	FORWARD
CKRA5006205A	5 ± 3	12	REVERSE
CKRA5006201A	1 ± 0.5	12	REVERSE

## INSTALLATION HOLE

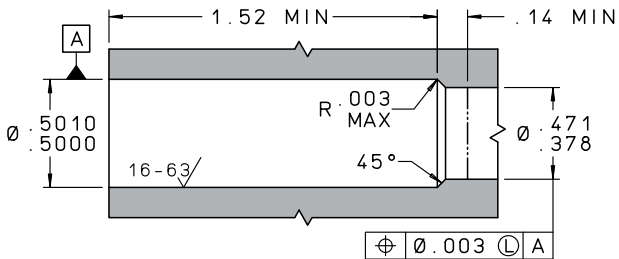

## INSTALLATION AND EXTRACTION

Tool Set Part Number ..... CUTA5000106C  
 Procedures ..... See [Pages N26 – N30](#)  
 Line Mount Configurations..... See [Pages L34 – L45](#)  
 Replacement Pin Part Number..... CKFA5000003A

*For boss size see [page N24](#). For oversize see [page N28](#).*

## PERFORMANCE

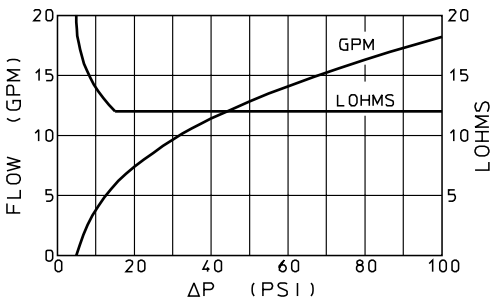

Cracking Pressure .....  $5 \pm 3$  or  $1 \pm 0.5$  psid  
 Maximum Leakage in ..... 1 drop/minute at 5 psid  
     checked direction ..... 1 drop/hour at 1000 - 3000 psid  
 Lohm rate at 15 psid and greater..... 12 Lohms Maximum  
 Nominal System Pressure ..... up to 3000 psi  
 Nominal Weight ..... 20 grams  
*Valve performance on MIL-PRF-83282 at 85°F. 1 drop = 50 μL*

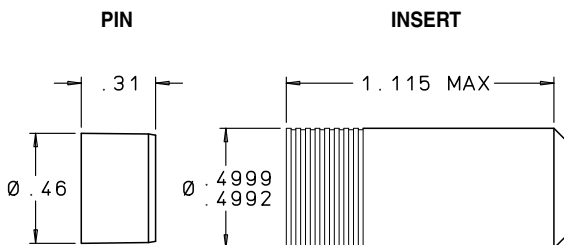

### MATERIALS

PART	MATERIAL	SPECIFICATION
Body, Front	15-5PH Cres	AMS 5659
Body, Rear*	304 Cres	AMS 5639
Poppet	440C Cres	AMS 5630
Spring	17-7PH Cres	AMS 5678
Cage	304 Cres	ASTM A 666
Pin	15-5PH Cres	AMS 5659

*Finish: All Cres Parts Passivated.*

*Pins are prewaxed. Do not degrease. Do not lubricate.*

*\*Reverse flow model only.*

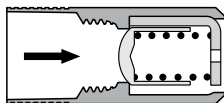

**CKFA5006405A • FREE FLOW FORWARD**

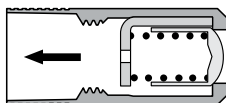

**CKRA5006405A • FREE FLOW REVERSE**

LEE PART NUMBER	CRACKING PRESSURE (psid)	LOHM RATE	FLOW DIRECTION
CKFA5006405A	5 ± 3	14	FORWARD
CKRA5006405A	5 ± 3	14	REVERSE

## INSTALLATION HOLE

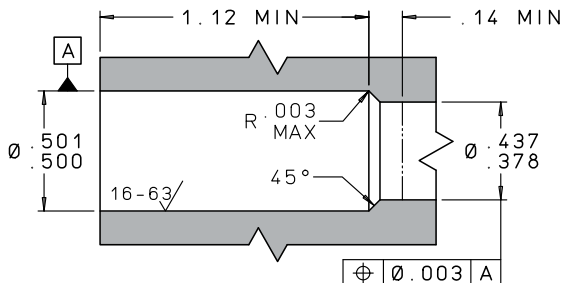

## INSTALLATION AND EXTRACTION

Tool Set Part Number ..... CUTA5000306C  
 Procedures ..... See **Pages N26 – N30**  
 Line Mount Configurations..... See **Pages L18 – L19**  
 Replacement Pin Part Number..... CKFA5000003A

*For boss size see **page N24**. For oversize see **page N28**.*

## PERFORMANCE

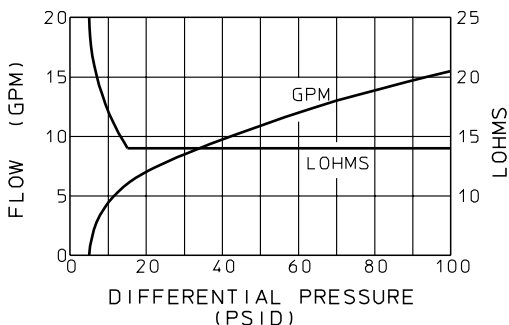

Cracking Pressure .....  $5 \pm 3$  psid  
 Maximum Leakage in ..... 1 drop/minute at 5 psid  
     checked direction           1 drop/hour at 1000 - 4000 psid  
 Lohm rate at 15 psid and greater..... 14 Lohms Maximum  
 Nominal System Pressure ..... up to 4000 psi  
 Nominal Weight ..... 9 grams  
*Valve performance on MIL-PRF-83282 at 85°F. 1 drop = 50  $\mu$ L*

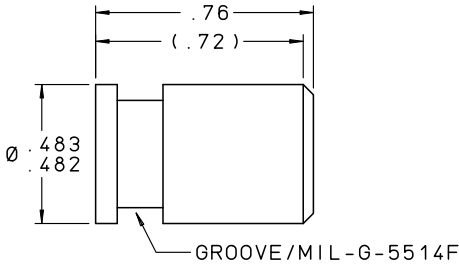

Customer Supplied: O-Ring M83461/1-012, Backup M8791/1-012

E

MATERIALS		
PART	MATERIAL	SPECIFICATION
Body	15-5PH Cres	AMS 5659
Poppet	440C Cres	AMS 5630
Spring	17-7PH Cres	AMS 5678
Retainer	304 Cres	QQ-P-35
Cage	304 Cres	ASTM A 666

Finish: All Cres Parts Passivated.

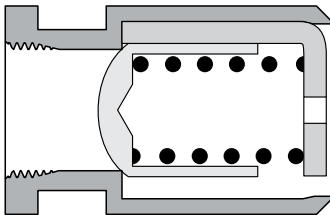

CKBA0500605A

LEE PART NUMBER	CRACKING PRESSURE (psid)	LOHM RATE
CKBA0500605A	5 ± 3	14

## INSTALLATION HOLE

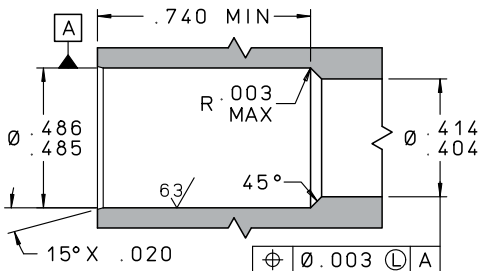

E

## PERFORMANCE

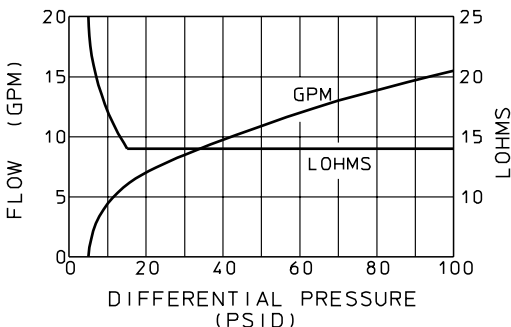

- Cracking Pressure .....  $5 \pm 3$  psid
- Maximum Leakage in ..... 1 drop/minute at 5 psid
- checked direction ..... 1 drop/hour at 1000 - 5000 psid
- Lohm rate at 15 psid and greater..... 14 Lohms Maximum
- Nominal System Pressure ..... up to 5000 psi
- Nominal Weight ..... 9 grams
- Valve performance on MIL-PRF-83282 at 85°F. 1 drop = 50  $\mu$ L

Note: For Line Mount Configuration see [pages L18 – L19](#).

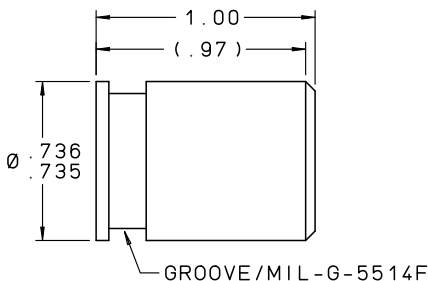

Customer Supplied: O-Ring M83461/1-016, Backup M8791/1-016

### MATERIALS

PART	MATERIAL	SPECIFICATION
Body	15-5PH Cres	AMS 5659
Poppet	440C Cres	AMS 5630
Spring	17-7PH Cres	AMS 5678
Retainer	304 Cres	QQ-P-35
Cage	304 Cres	ASTM A 666

Finish: All Cres Parts Passivated.

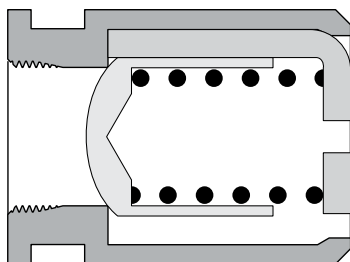

CKBA0750605A

LEE PART NUMBER	CRACKING PRESSURE (psid)	LOHM RATE
CKBA0750605A	5 ± 3	7.5

## INSTALLATION HOLE

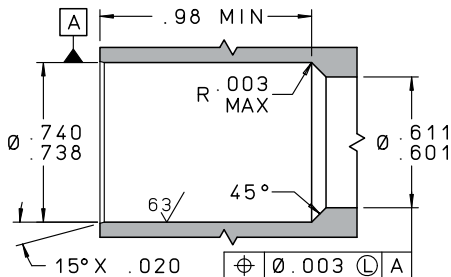

## PERFORMANCE

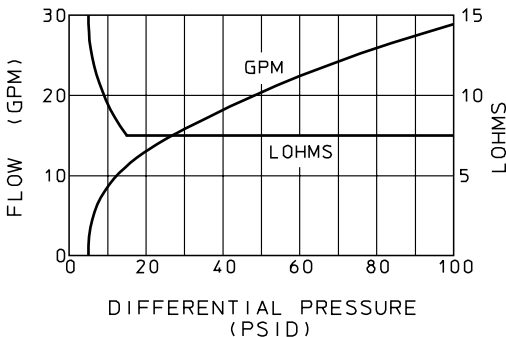

- Cracking Pressure .....  $5 \pm 3$  psid
- Maximum Leakage in ..... 1 drop/minute at 5 psid  
checked direction ..... 1 drop/hour at 1000 - 5000 psid
- Lohm rate at 15 psid and greater..... 7.5 Lohms Maximum
- Nominal System Pressure ..... up to 5000 psi
- Nominal Weight ..... 30 grams
- Valve performance on MIL-PRF-83282 at 85°F. 1 drop = 50  $\mu$ L

Note: For Line Mount Configurations see [pages L18 – L19](#).

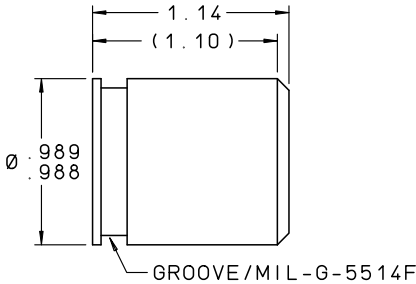

Customer Supplied: O-Ring M83461/1-020, Backup M8791/1-020

**MATERIALS**

PART	MATERIAL	SPECIFICATION
Body	15-5PH Cres	AMS 5659
Poppet	440C Cres	AMS 5630
Spring	17-7PH Cres	AMS 5678
Retainer	304 Cres	QQ-P-35
Cage	304 Cres	ASTM A 666

Finish: All Cres Parts Passivated.

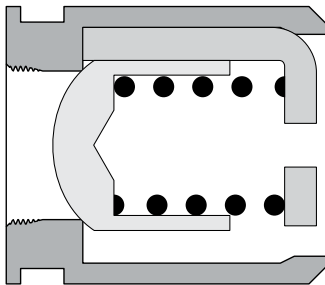

CKBA1000605A

LEE PART NUMBER	CRACKING PRESSURE (psid)	LOHM RATE
CKBA1000605A	5 ± 3	3.5

## INSTALLATION HOLE

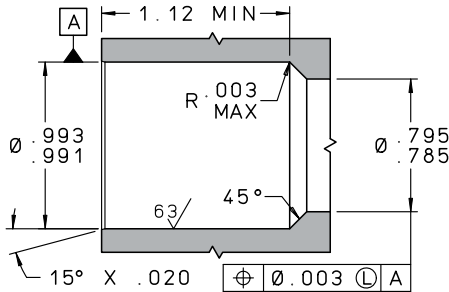

E

## PERFORMANCE

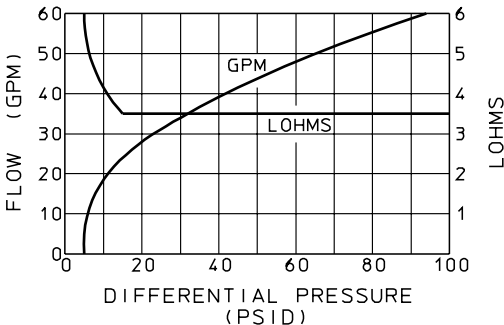

- Cracking Pressure .....  $5 \pm 3$  psid
- Maximum Leakage in ..... 1 drop/minute at 5 psid  
checked direction ..... 1 drop/hour at 1000 - 5000 psid
- Lohm rate at 15 psid and greater ..... 3.5 Lohms Maximum
- Nominal System Pressure ..... up to 5000 psi
- Nominal Weight ..... 55 grams
- Valve performance on MIL-PRF-83282 at 85°F. 1 drop = 50  $\mu$ L

Note: For Line Mount Configurations see [pages L18 – L19](#).

PIN

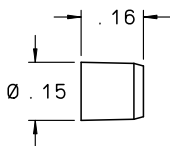

INSERT

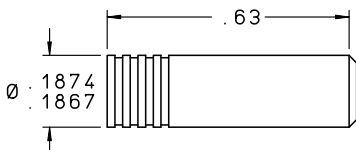

## MATERIALS

PART	MATERIAL	SPECIFICATION
Body	304 Cres	AMS 5639
Cage	304 Cres	AMS 5639
Poppet	15-5PH Cres	AMS 5659
Seat	15-5PH Cres	AMS 5659
Spring	17-7PH Cres	AMS 5678
Pin	17-4PH Cres	AMS 5643
Elastomeric Seat	Fluorocarbon	AMS-R-83485 or AMS-R-83248
	EPDM	MIL-R-83285

*Each valve contains one of the following elastomeric materials.*

*Finish: All Cres Parts Passivated.*

*Pins are prewaxed. Do not degrease. Do not lubricate.*

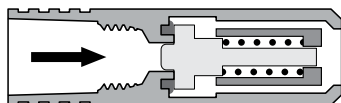

CSFA1876000A • FREE FLOW FORWARD

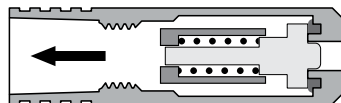

CSRA1876000A • FREE FLOW REVERSE

## INSTALLATION HOLE

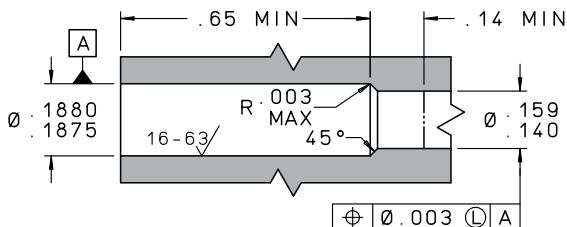

## INSTALLATION AND EXTRACTION

Tool Set Part Number ..... CUTA1870110C  
 Procedures ..... See [Pages N26 – N30](#)  
 Line Mount Configurations..... See [Pages L6 – L8](#)  
 Replacement Pin Part Number..... CSFA1870003A  
*For boss size see [page N24](#). For oversize see [page N28](#).*

LEE PART NUMBER	CRACKING PRESSURE (psid)	LOHM RATE	SEAT MATERIAL	FLOW DIRECTION	TEMP. RANGE (°F)
CSFA1876005A	$5 \pm 3$	400	Fluorocarbon	Forward	0 / +395
CSRA1876005A	$5 \pm 3$	400	Fluorocarbon	Reverse	0 / +395
CSFA1876105A	$5 \pm 3$	400	EPDM	Forward	-65 / +290
CSRA1876105A	$5 \pm 3$	400	EPDM	Reverse	-65 / +290

## PERFORMANCE

Cracking Pressure .....  $5 \pm 3$  psid  
 Free Flow ..... 400 Lohms Max. Restriction when fully open  
 Leakage in Checked Direction..... Zero Leakage from 5-3000 psid  
 Nominal System Pressure..... up to 3000 psi  
 Nominal Weight ..... 2.3 grams  
 Test Fluid ..... Air at 70°F

SCREEN

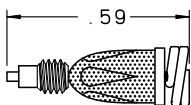

PIN

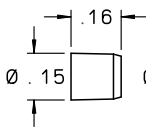

INSERT

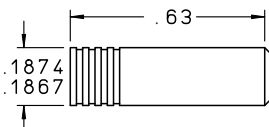

## MATERIALS

PART	MATERIAL	SPECIFICATION
Body	304 Cres	AMS 5639
Cage	304 Cres	AMS 5639
Poppet	15-5PH Cres	AMS 5659
Seat	15-5PH Cres	AMS 5659
Spring	17-7PH Cres	AMS 5678
Pin	17-4PH Cres	AMS 5643
Screen	304L Cres	AMS 5647
Braze	—	AMS 4774
Post	303 Cres	AMS 5640
Spring (screen)	17-7PH Cres	AMS 5678
Elastomeric Seat	Fluorocarbon	AMS-R-83485
<i>Each valve contains one of the following elastomeric materials.</i>		or AMS-R-83248
	EPDM	AMS-R-83285

*Finish: All Cres Parts Passivated.*

*Pins are prewaxed. Do not degrease. Do not lubricate.*

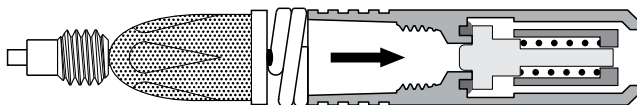

**CSFA1875000A • FREE FLOW FORWARD**

*Note: For additional screen information see [page I73](#).*

### INSTALLATION HOLE

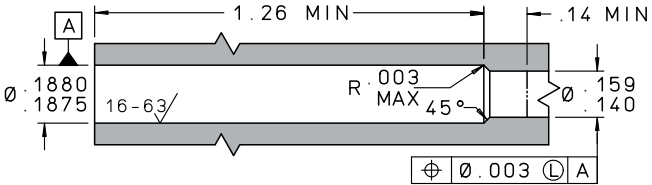

### INSTALLATION AND EXTRACTION

Tool Set Part Number: Insert..... CUTA1870110C  
 Screen..... CUTA1870228C  
 Procedures ..... See **Pages N26 – N30**  
 Replacement Pin Part Number..... CSFA1870003A  
 Replacement Screen Part Number..... FSSA1870150B

*For boss size see **page N24**. For oversize see **page N28**.*

LEE PART NUMBER	CRACKING PRESSURE (psid)	LOHM RATE	SEAT MATERIAL	FLOW DIRECTION	TEMP. RANGE (°F)
CSFA1875005A	5 ± 3	400	Fluorocarbon	Forward	0 / +395
CSFA1875105A	5 ± 3	400	EPDM	Forward	-65 / +290

### PERFORMANCE

Cracking Pressure ..... 5 ± 3 psid  
 Free Flow ..... 400 Lohms Max. Restriction when fully open  
 Leakage in Checked Direction..... Zero Leakage from 5-3000 psid  
 Screen Hole Size ..... 0.015" Nominal  
 Nominal System Pressure..... up to 3000 psi  
 Nominal Weight ..... Valve: 2.3 grams / Screen: .4 grams  
 Test Fluid ..... Air at 70°F

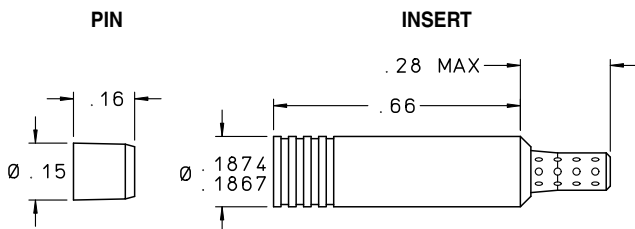

## E

MATERIALS		
PART	MATERIAL	SPECIFICATION
Body	304 Cres	AMS 5639
Cage	304 Cres	AMS 5639
Poppet	15-5PH Cres	AMS 5659
Seat	15-5PH Cres	AMS 5659
Spring	17-7PH Cres	AMS 5678
Pin	17-4PH Cres	AMS 5643
Screen	303 Cres	AMS 5640
Elastomeric Seat	Fluorocarbon	AMS-R-83485
<i>Each valve contains one of the following elastomeric materials.</i>		or AMS-R-83248
	EPDM	AMS-R-83285

*Finish: All Cres Parts Passivated.*

*Pins are prewaxed. Do not degrease. Do not lubricate.*

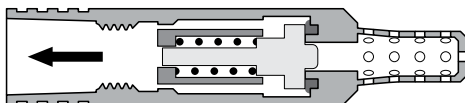

**CSRA1875005A • FREE FLOW REVERSE**

### INSTALLATION HOLE

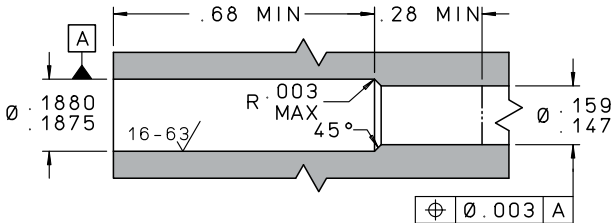

### INSTALLATION AND EXTRACTION

Tool Set Part Number ..... CUTA1870110C  
 Procedures ..... See [Pages N26 – N30](#)  
 Line Mount Configurations..... See [Pages L6 – L8](#)  
 Replacement Pin Part Number..... CSFA1870003A

*For boss size see [page N24](#). For oversize see [page N28](#).*

LEE PART NUMBER	CRACKING PRESSURE (psid)	LOHM RATE	SEAT MATERIAL	FLOW DIRECTION	TEMP. RANGE (°F)
CSRA1875005A	$5 \pm 3$	400	Fluorocarbon	Reverse	0 / +395
CSRA1875105A	$5 \pm 3$	400	EPDM	Reverse	-65 / +290

### PERFORMANCE

Cracking Pressure .....  $5 \pm 3$  psid  
 Free Flow ..... 400 Lohms Max. Restriction when fully open  
 Leakage in Checked Direction..... Zero Leakage from 5-3000 psid  
 Screen Hole Size ..... 0.015" Nominal  
 Nominal System Pressure..... up to 3000 psi  
 Nominal Weight ..... Valve: 2.3 grams / Screen: .4 grams  
 Test Fluid ..... Air at 70°F

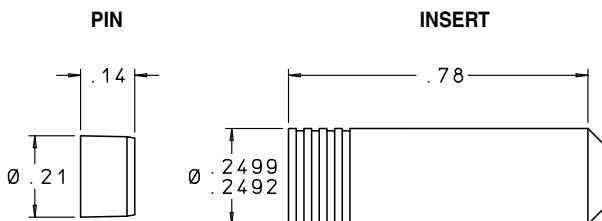

### MATERIALS

PART	MATERIAL	SPECIFICATION
Body	304 Cres	AMS 5639
Poppet	15-5PH Cres	AMS 5659
Seat	304 Cres	AMS 5639
Spring	17-7PH Cres	AMS 5678
Pin	17-4PH Cres	AMS 5643
Elastomeric Seat <i>Each valve contains one of the following elastomeric materials.</i>	Fluorocarbon	AMS-R-83485 or AMS-R-83248
	EPDM	MIL-R-83285

*Finish: All Cres Parts Passivated.*

*Pins are prewaxed. Do not degrease. Do not lubricate.*

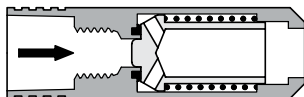

**CSFA2506005A • FREE FLOW FORWARD**

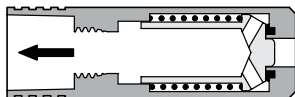

**CSRA2506005A • FREE FLOW REVERSE**

LEE PART NUMBER	CRACKING PRESSURE (psid)	LOHM RATE (Max.)	SCREEN HOLE SIZE (Inches)	FLOW DIRECTION
CSRA2506005A	5 ± 3	180	Fluorocarbon	REVERSE
CSFA2506005A	5 ± 3	180	Fluorocarbon	FORWARD
CSRA2506105A	5 ± 3	180	EPDM	REVERSE
CSFA2506105A	5 ± 3	180	EPDM	FORWARD

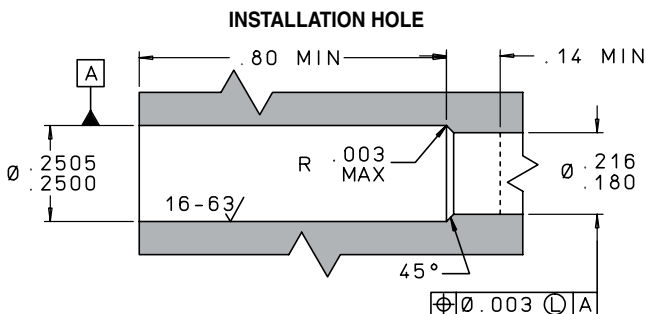

## INSTALLATION AND EXTRACTION

Tool Set Part Number ..... CUTA2500506C  
 Procedures ..... See [Pages N26 – N30](#)  
 Line Mount Configurations..... See [Pages L9 – L12](#)  
 Replacement Pin Part Number..... CKFA2500005A

*For boss size see [page N24](#). For oversize see [page N28](#).*

## PERFORMANCE

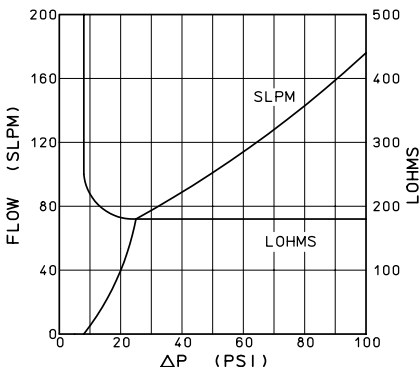

Cracking Pressure .....  $5 \pm 3$  psid  
 Free Flow..... 180 Lohms Max. Restriction when fully open  
 Leakage in Checked Direction... Zero Leakage from 5-3000 psid  
 Nominal System Pressure ..... up to 3000 psi  
 Nominal Weight ..... 3.8 grams  
 Test Fluid ..... Air at 70°F

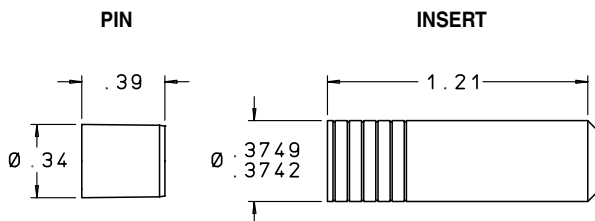

MATERIALS		
PART	MATERIAL	SPECIFICATION
Body	15-5PH Cres	AMS 5659
Poppet	15-5PH Cres	AMS 5659
Seat	15-5PH Cres	AMS 5659
Spring	17-7PH Cres	AMS 5678
Pin	17-4PH Cres	AMS 5643
Elastomeric Seat <i>Each Valve Contains one of the following elastomeric materials.</i>	Fluorocarbon	AMS-R-83485 or AMS-R-83248
	EPDM	MIL-R-83285

*Finish: All Cres Parts Passivated.*

*Pins are prewaxed. Do not degrease. Do not lubricate.*

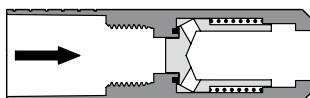

**FREE FLOW FORWARD**

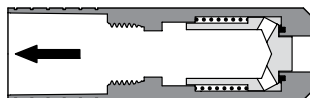

**FREE FLOW REVERSE**

LEE PART NUMBER	CRACKING PRESSURE (psid)	LOHM RATE (Max.)	SEAT MATERIAL	FLOW DIRECTION
CSFA3756008A	8 maximum	45	Fluorocarbon	Forward
CSRA3756008A	8 maximum	45	Fluorocarbon	Reverse
CSFA3756108A	8 maximum	45	EPDM	Forward
CSRA3756108A	8 maximum	45	EPDM	Reverse

## INSTALLATION HOLE

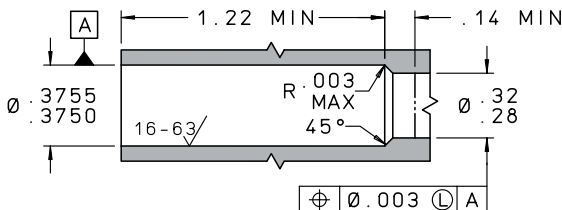

## INSTALLATION AND EXTRACTION

Tool Set Part Number ..... CUTA3750306C  
 Procedures ..... See **Pages N26 – N30**  
 Replacement Pin Part Number ..... PHRA3750003A

*For boss size see **page N24**. For oversize see **page N28**.*

**E**

## PERFORMANCE

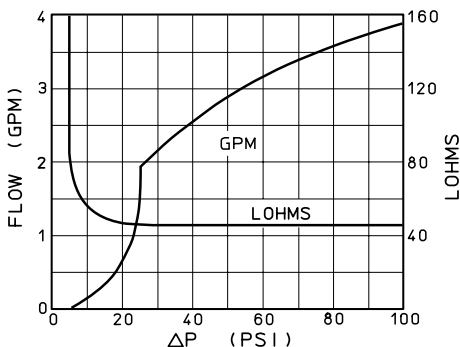

Cracking Pressure .....8 psid Maximum  
 Free Flow ..... 45 Lohms Max. Restriction when fully open  
 Leakage in Checked Direction...Zero Leakage from 5-5000 psid  
 Nominal System Pressure..... up to 5000 psi  
 Nominal Weight ..... 11 grams  
 Test Fluid .....Air or Nitrogen  
 Valve performance on MIL-PRF-83282 at 85°F. 1 drop = 50 μL

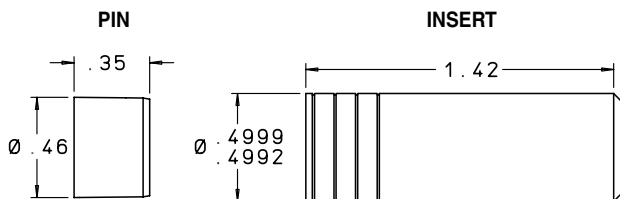

MATERIALS		
PART	MATERIAL	SPECIFICATION
Body	15-5PH Cres	AMS 5659
Poppet	15-5PH Cres	AMS 5659
Seat	15-5PH Cres	AMS 5659
Spring	17-7PH Cres	AMS 5678
Pin	15-5PH Cres	AMS 5659
Elastomeric Seat <i>Each Valve Contains one of the following elastomeric materials.</i>	Fluorocarbon	AMS-R-83485 or AMS-R-83248
	EPDM	AMS-R-83285

*Finish: All Cres per AMS 2700.*

*Pins are prewaxed. Do not degrease. Do not lubricate.*

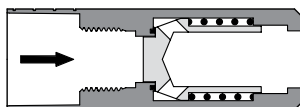

**FREE FLOW FORWARD**

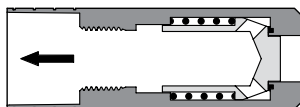

**FREE FLOW REVERSE**

LEE PART NUMBER	CRACKING PRESSURE (psid)	LOHM RATE (Max.)	SEAT MATERIAL	FLOW DIRECTION
CSFA5006008A	8 maximum	25	Fluorocarbon	Forward
CSRA5006008A	8 maximum	25	Fluorocarbon	Reverse
CSFA5006108A	8 maximum	25	EPDM	Forward
CSRA5006108A	8 maximum	25	EPDM	Reverse

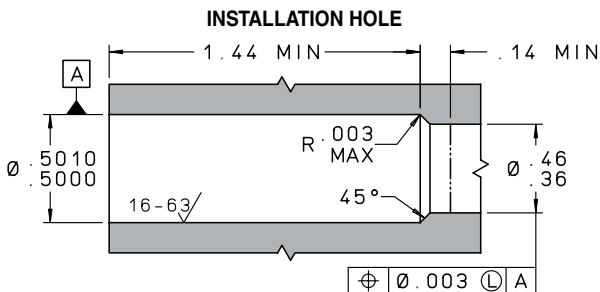

## INSTALLATION AND EXTRACTION

Tool Set Part Number ..... CUTX0509500B  
 Procedures ..... See **Pages N26 – N30**  
 Replacement Pin Part Number ..... SVBA5000003A

*For boss size see **page N24**. For oversize see **page N28**.*

## PERFORMANCE

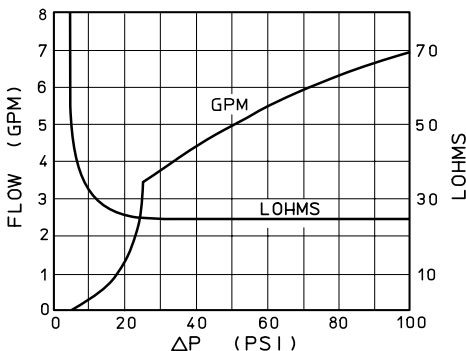

Cracking Pressure ..... 8 psid Maximum  
 Free Flow ..... 25 Lohms Max. Restriction when fully open  
 Leakage in Checked Direction... Zero Leakage from 5-5000 psid  
 Nominal System Pressure..... up to 5000 psi  
 Nominal Weight ..... 24 grams  
 Test Fluid ..... Air or Nitrogen  
 Valve performance on MIL-PRF-83282 at 85°F. 1 drop = 50  $\mu$ L

PIN

INSERT

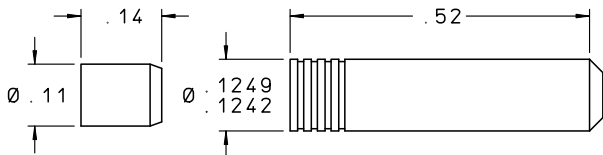

## MATERIALS

PART	MATERIAL	SPECIFICATION
Body	304 Cres	AMS 5639
Pin	13-8 MO Cres	AMS 5629
Poppet	15-5PH Cres	AMS 5659
Spring	17-7PH Cres	AMS 5678
Spring Seat	304 Cres	AMS 5639

*Finish: All Cres Parts Passivated.*

*Pins are prewaxed. Do not degrease. Do not lubricate.*

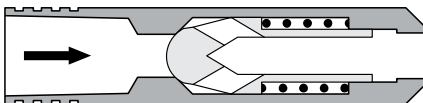

**CHFA1256505A • FREE FLOW FORWARD**

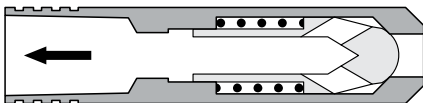

**CHRA1256505A • FREE FLOW REVERSE**

LEE PART NUMBER	CRACKING PRESSURE (psid)	LOHM RATE	FLOW DIRECTION
CHFA1256505A	5 ± 3	400	FORWARD
CHFA1256501A	1 ± 0.5	400	FORWARD
CHRA1256505A	5 ± 3	400	REVERSE
CHRA1256501A	1 ± 0.5	400	REVERSE

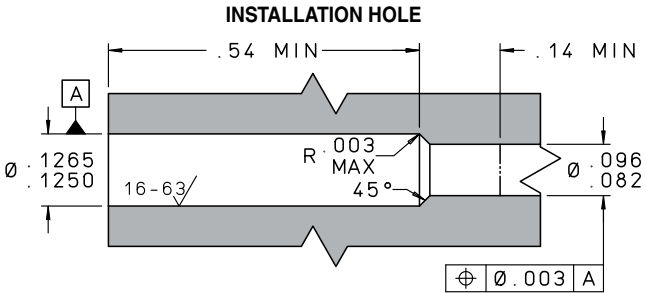

## INSTALLATION AND EXTRACTION

Tool Set Part Number ..... CUTA1250306C

Procedures ..... See **Pages N26 – N30**

*For boss size see **page N24**. For oversize see **page N28**.*

## PERFORMANCE

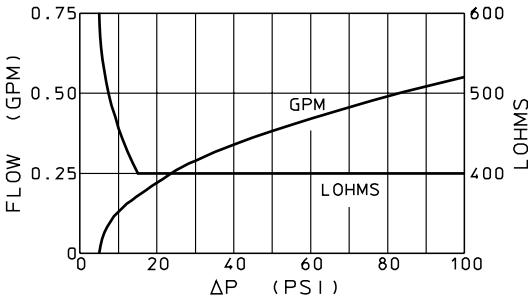

Cracking Pressure .....  $5 \pm 3$  or  $1 \pm 0.5$  psid

Maximum Leakage in ..... 1 drop/minute at 5 psid  
 checked direction ..... 1 drop/hour at 1000 - 8000 psid

Lohm rate at 15 psid and greater..... 400 Lohms Maximum

Nominal System Pressure ..... up to 8000 psi

Nominal Weight ..... 0.6 grams

*Valve performance on MIL-PRF-83282 at 85°F. 1 drop = 50  $\mu$ L*

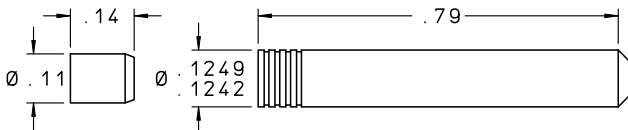
**60****Forward Screened  
High Pressure****125 Chek****PIN****INSERT****E****MATERIALS**

PART	MATERIAL	SPECIFICATION
Body	304 Cres	AMS 5639
Pin	13-8 MO Cres	AMS 5629
Poppet	15-5PH Cres	AMS 5659
Spring	17-7PH Cres	AMS 5678
Spring Seat	304 Cres	AMS 5639

*Finish: All Cres Parts Passivated.*

*Pins are prewaxed. Do not degrease. Do not lubricate.*

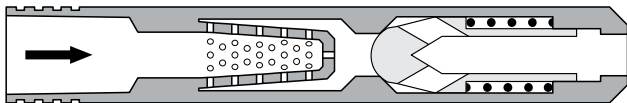
**CHFA1255505A • FREE FLOW FORWARD**

LEE PART NUMBER	CRACKING PRESSURE (psid)	LOHM RATE	SCREEN HOLE SIZE (Inches)	FLOW DIRECTION
CHFA1255505A	5 ± 3	460	0.008	FORWARD
CHFA1255501A	1 ± 0.5	460	0.008	FORWARD

## INSTALLATION HOLE

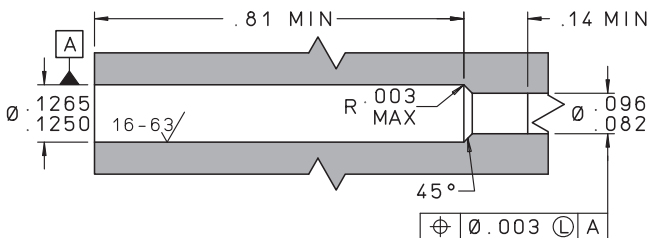

## INSTALLATION AND EXTRACTION

Tool Set Part Number ..... CUTA1250306C

Procedures ..... See Pages N26 – N30

*For boss size see page N24. For oversize see page N28.*

## PERFORMANCE

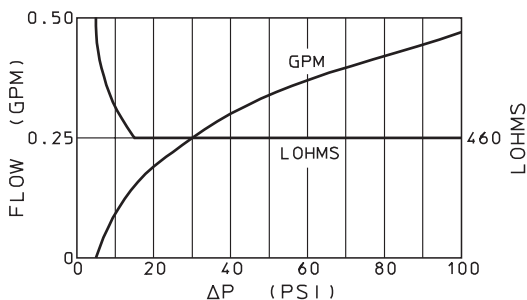

Cracking Pressure .....  $5 \pm 3$  or  $1 \pm 0.5$  psid

Maximum Leakage in ..... 1 drop/minute at 5 psid  
checked direction ..... 1 drop/hour at 1000 - 8000 psid

Lohm rate at 15 psid and greater ..... 460 Lohms Maximum

Nominal System Pressure ..... up to 8000 psi

Nominal Weight ..... 0.8 grams

*Valve performance on MIL-PRF-83282 at 85°F. 1 drop = 50  $\mu$ L*

PIN

INSERT

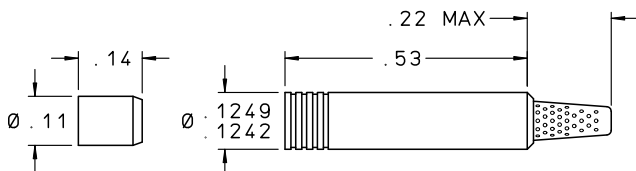

E

## MATERIALS

PART	MATERIAL	SPECIFICATION
Body	304 Cres	AMS 5639
Pin	13-8 MO Cres	AMS 5629
Poppet	15-5PH Cres	AMS 5659
Spring	17-7PH Cres	AMS 5678
Spring Seat	304 Cres	AMS 5639
Screen	15-5PH Cres	AMS 5659

Finish: All Cres Parts Passivated.

Pins are prewaxed. Do not degrease. Do not lubricate.

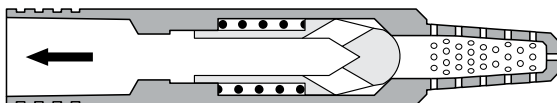

CHRA1255505A • FREE FLOW REVERSE

LEE PART NUMBER	CRACKING PRESSURE (psid)	LOHM RATE	SCREEN HOLE SIZE (Inches)	FLOW DIRECTION
CHRA1255505A	5 ± 3	460	0.008	REVERSE
CHRA1255501A	1 ± 0.5	460	0.008	REVERSE

## INSTALLATION HOLE

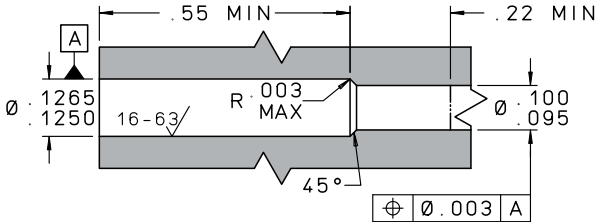

## INSTALLATION AND EXTRACTION

Tool Set Part Number ..... CUTA1250306C

Procedures ..... See [Pages N26 – N30](#)

*For boss size see [page N24](#). For oversize see [page N28](#).*

## PERFORMANCE

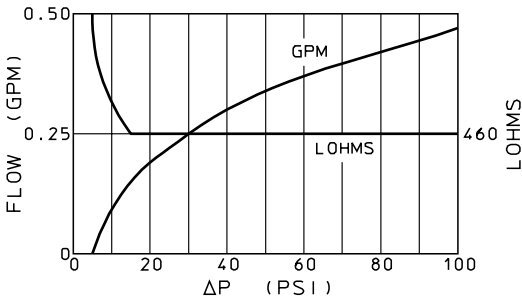

Cracking Pressure .....  $5 \pm 3$  or  $1 \pm 0.5$  psid

Maximum Leakage in ..... 1 drop/minute at 5 psid  
checked direction ..... 1 drop/hour at 1000 - 8000 psid

Lohm rate at 15 psid and greater ..... 460 Lohms

Nominal System Pressure ..... up to 8000 psi

Nominal Weight ..... 0.7 grams

*Valve performance on MIL-PRF-83282 at 85°F. 1 drop = 50  $\mu$ L*

PIN

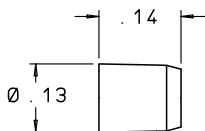

INSERT

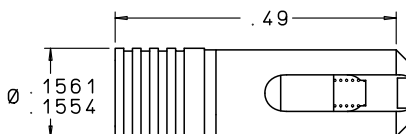

## E

## MATERIALS

PART	MATERIAL	SPECIFICATION
Body	15-5PH Cres	AMS 5659
Pin	13-8 MO Cres	AMS 5629
Spring	302 Cres	AMS 5688
Ball	440C Cres	AMS 5630
Ball Follower	15-5PH Cres	AMS 5659

*Finish: All Cres Parts Passivated.*

*Pins are prewaxed. Do not degrease. Do not lubricate.*

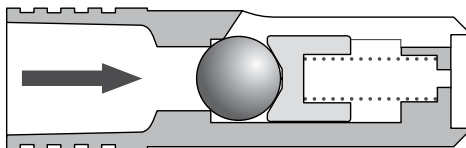

CHFA1566505A • FREE FLOW FORWARD

LEE PART NUMBER	CRACKING PRESSURE (psid)	LOHM RATE	FLOW DIRECTION
CHFA1566505A	5 ± 3	250	FORWARD
CHFA1566501A	1 ± 0.5	250	FORWARD

## INSTALLATION HOLE

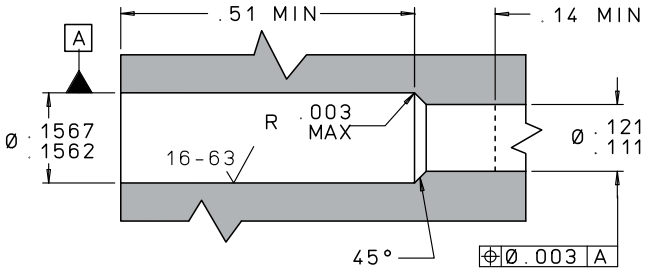

## INSTALLATION AND EXTRACTION

Tool Set Part Number ..... CUTA1560106C

Procedures ..... See **Pages N26 – N30**

*For boss size see **page N24**. For oversize see **page N28**.*

## PERFORMANCE

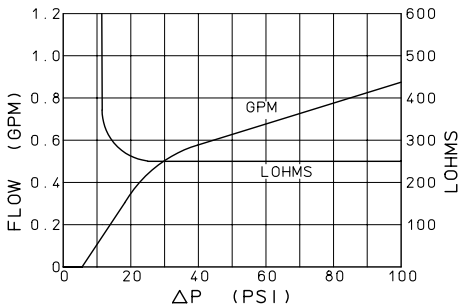

Cracking Pressure .....  $5 \pm 3$  or  $1 \pm 0.5$  psid

Maximum Leakage in ..... 1 drop/minute at 5 psid  
checked direction ..... 1 drop/hour at 1000 - 5000 psid

Lohm rate at 15 psid and greater ..... 250 Lohms Maximum

Nominal System Pressure ..... up to 5000 psi

Nominal Weight ..... 0.7 grams

*Valve performance on MIL-PRF-83282 at 85°F. 1 drop = 50 μL*

PIN

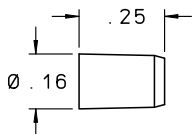

INSERT

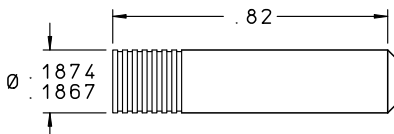

## MATERIALS

PART	MATERIAL	SPECIFICATION
Body	304 Cres	AMS 5639
Pin	17-4PH Cres	AMS 5643
Poppet	15-5PH Cres	AMS 5659
Spring	17-7PH Cres	AMS 5678
Spring Seat	304 Cres	AMS 5639

*Finish: All Cres Parts Passivated.*

*Pins are prewaxed. Do not degrease. Do not lubricate.*

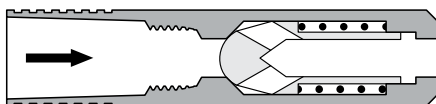

CHFA1876505A • FREE FLOW FORWARD

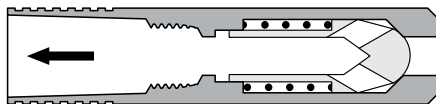

CHRA1876505A • FREE FLOW REVERSE

LEE PART NUMBER	CRACKING PRESSURE (psid)	LOHM RATE	FLOW DIRECTION
CHFA1876505A	5 ± 3	210	FORWARD
CHFA1876501A	1 ± 0.5	210	FORWARD
CHRA1876505A	5 ± 3	210	REVERSE
CHRA1876501A	1 ± 0.5	210	REVERSE

## INSTALLATION HOLE

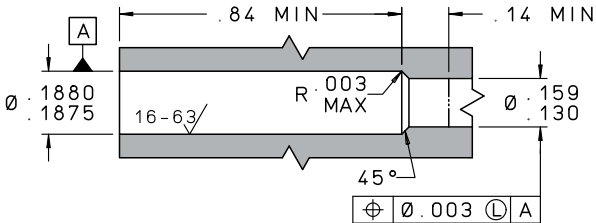

## INSTALLATION AND EXTRACTION

Tool Set Part Number ..... CUTA1870210C  
 Procedures ..... See [Pages N26 – N30](#)  
 Line Mount Configurations..... See [Page L8](#)  
 Replacement Pin Part Number..... JHHA1870003A  
*For boss size see [page N24](#). For oversize see [page N28](#).*

## PERFORMANCE

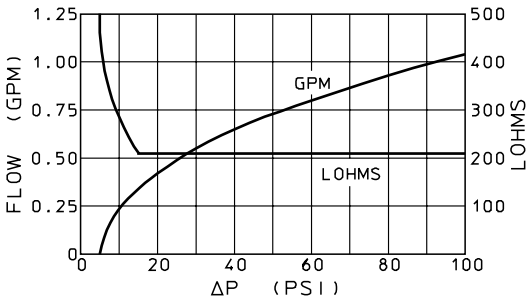

Cracking Pressure .....  $5 \pm 3$  or  $1 \pm 0.5$  psid  
 Maximum Leakage in ..... 1 drop/minute at 5 psid  
     checked direction ..... 1 drop/hour at 1000 - 8000 psid  
 Lohm rate at 15 psid and greater..... 210 Lohms Maximum  
 Nominal System Pressure ..... up to 8000 psi  
 Nominal Weight ..... 2.0 grams  
*Valve performance on MIL-PRF-83282 at 85°F. 1 drop = 50  $\mu$ L*

SCREEN

PIN

INSERT

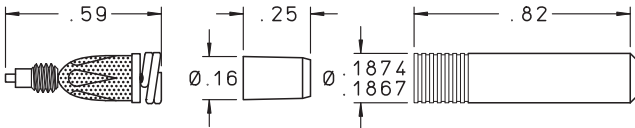

### MATERIALS

PART	MATERIAL	SPECIFICATION
Body	304 Cres	AMS 5639
Pin	17-4PH Cres	AMS 5643
Poppet	15-5PH Cres	AMS 5659
Springs	17-7PH Cres	AMS 5678
Spring Seat	304 Cres	AMS 5639
Screen	304L Cres	ASTM A 666
Braze	—	AMS 4774
Post	303 Cres	QQ-S-763C

*Finish: All Cres Parts Passivated.*

*Pins are prewaxed. Do not degrease. Do not lubricate.*

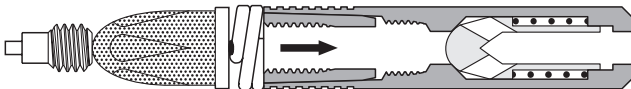

### CHFA1875505A • FREE FLOW FORWARD

LEE PART NUMBER	CRACKING PRESSURE (psid)	LOHM RATE	SCREEN HOLE SIZE (Inches)	FLOW DIRECTION
CHFA1875505A	$5 \pm 3$	250	0.015	FORWARD
CHFA1875501A	$1 \pm 0.5$	250	0.015	FORWARD

*Note: For additional screen information see page I73.*

## INSTALLATION HOLE

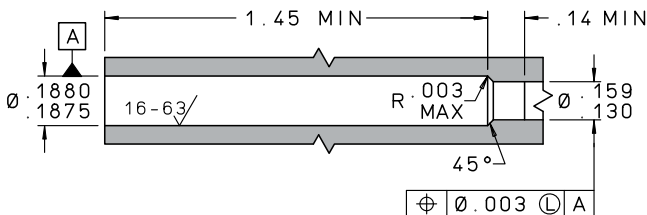

## INSTALLATION AND EXTRACTION

Tool Set Part Number: Insert..... CUTA1870210C  
 Screen..... CUTA1870228C  
 Procedures ..... See **Pages N26 – N30**  
 Replacement Pin Part Number..... JHHA1870003A  
*For boss size see **page N24**. For oversize see **page N28**.*

## PERFORMANCE

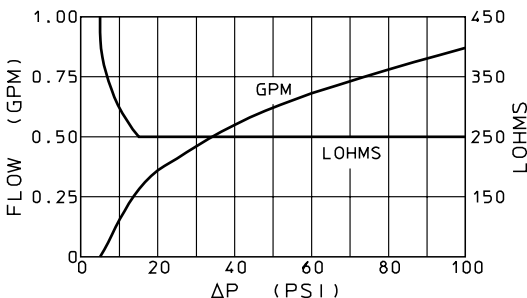

Cracking Pressure .....  $5 \pm 3$  or  $1 \pm 0.5$  psid  
 Maximum Leakage in ..... 1 drop/minute at 5 psid  
     checked direction ..... 1 drop/hour at 1000 - 8000 psid  
 Lohm rate at 15 psid and greater..... 250 Lohms Maximum  
 Nominal System Pressure ..... up to 8000 psi  
 Nominal Weight ..... 2.4 grams  
*Valve performance on MIL-PRF-83282 at 85°F. 1 drop = 50  $\mu$ L*

70

# Reverse Screened High Pressure 187 Chek

PIN

INSERT

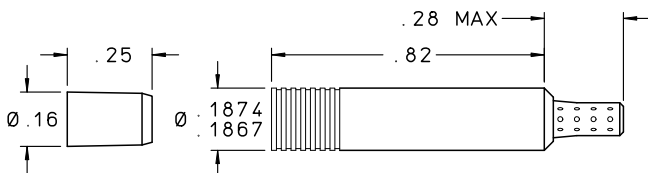

E

## MATERIALS

PART	MATERIAL	SPECIFICATION
Body	304 Cres	AMS 5639
Pin	17-4PH Cres	AMS 5643
Poppet	15-5PH Cres	AMS 5659
Spring	17-7PH Cres	AMS 5678
Spring Seat	304 Cres	AMS 5639
Screen	303 Cres	QQ-S-763C

*Finish: All Cres Parts Passivated.*

*Pins are prewaxed. Do not degrease. Do not lubricate.*

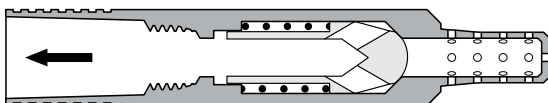

**CHRA1875505A • FREE FLOW REVERSE**

LEE PART NUMBER	CRACKING PRESSURE (psid)	LOHM RATE	SCREEN HOLE SIZE (Inches)	FLOW DIRECTION
CHRA1875505A	5 ± 3	250	0.015	REVERSE
CHRA1875501A	1 ± 0.5	250	0.015	REVERSE

## INSTALLATION HOLE

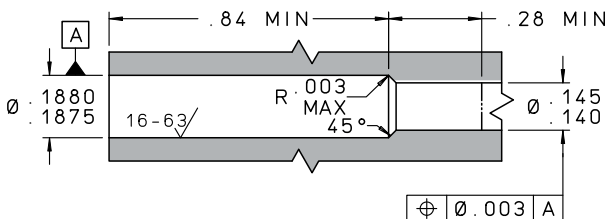

## INSTALLATION AND EXTRACTION

Tool Set Part Number ..... CUTA1870210C  
 Procedures ..... See **Pages N26 – N30**  
 Line Mount Configurations..... See **Page L8**  
 Replacement Pin Part Number..... JHHA1870003A

*For boss size see **page N24**. For oversize see **page N28**.*

## PERFORMANCE

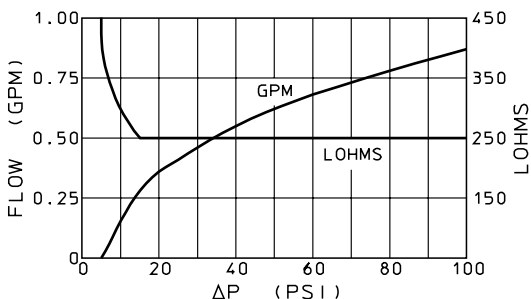

Cracking Pressure .....  $5 \pm 3$  or  $1 \pm 0.5$  psid  
 Maximum Leakage in ..... 1 drop/minute at 5 psid  
     checked direction ..... 1 drop/hour at 1000 - 8000 psid  
 Lohm rate at 15 psid and greater..... 250 Lohms Maximum  
 Nominal System Pressure ..... up to 8000 psi  
 Nominal Weight ..... 2.2 grams  
*Valve performance on MIL-PRF-83282 at 85°F. 1 drop = 50  $\mu$ L*

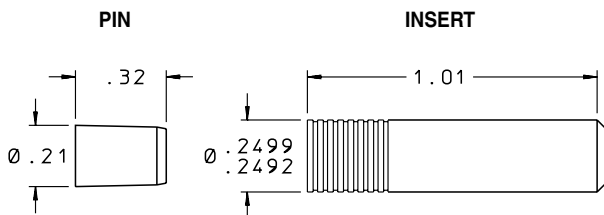

### MATERIALS

PART	MATERIAL	SPECIFICATION
Body	304 Cres	AMS 5639
Pin	17-4PH Cres	AMS 5643
Poppet	15-5PH Cres	AMS 5659
Spring	17-7PH Cres	AMS 5678
Spring Seat	304 Cres	AMS 5639

*Finish: All Cres Parts Passivated.*

*Pins are prewaxed. Do not degrease. Do not lubricate.*

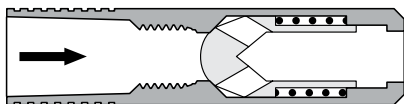

**CHFA2506505A • FREE FLOW FORWARD**

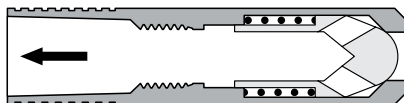

**CHRA2506505A • FREE FLOW REVERSE**

LEE PART NUMBER	CRACKING PRESSURE (psid)	LOHM RATE	FLOW DIRECTION
CHFA2506505A	5 ± 3	60	FORWARD
CHFA2506501A	1 ± 0.5	60	FORWARD
CHRA2506505A	5 ± 3	60	REVERSE
CHRA2506501A	1 ± 0.5	60	REVERSE

## INSTALLATION HOLE

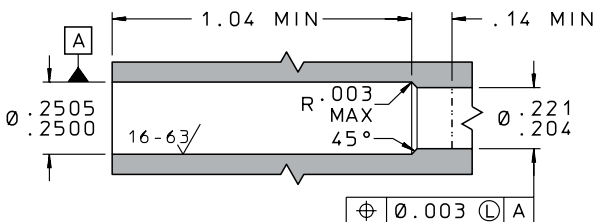

## INSTALLATION AND EXTRACTION

Tool Set Part Number ..... CUTA2500406C  
 Procedures ..... See **Pages N26 – N30**  
 Line Mount Configurations..... See **Pages L11 – L12, L34 – L35, L40 – L41**  
 Replacement Pin Part Number..... CHFA2500003A  
*For boss size see **page N24**. For oversize see **page N28**.*

## PERFORMANCE

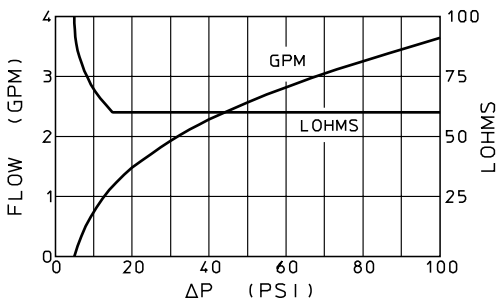

Cracking Pressure .....  $5 \pm 3$  or  $1 \pm 0.5$  psid  
 Maximum Leakage in ..... 1 drop/minute at 5 psid  
     checked direction ..... 1 drop/hour at 1000 - 8000 psid  
 Lohm rate at 15 psid and greater..... 60 Lohms Maximum  
 Nominal System Pressure ..... up to 8000 psi  
 Nominal Weight ..... 4.1 grams  
*Valve performance on MIL-PRF-83282 at 85°F: 1 drop = 50  $\mu$ L*

PIN

INSERT

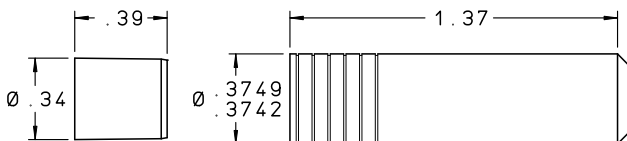

## MATERIALS

PART	MATERIAL	SPECIFICATION
Body	304 Cres	AMS 5639
Pin	17-4PH Cres	AMS 5643
Poppet	15-5PH Cres	AMS 5659
Spring	17-7PH Cres	AMS 5678
Spring Seat	304 Cres	AMS 5639

*Finish: All Cres Parts Passivated.*

*Pins are prewaxed. Do not degrease. Do not lubricate.*

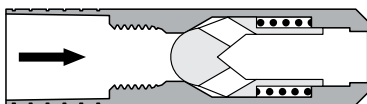

**CHFA3756505A • FREE FLOW FORWARD**

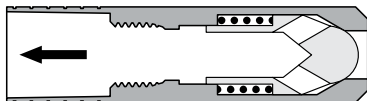

**CHRA3756505A • FREE FLOW REVERSE**

LEE PART NUMBER	CRACKING PRESSURE (psid)	LOHM RATE	FLOW DIRECTION
CHFA3756505A	5 ± 3	27	FORWARD
CHFA3756501A	1 ± 0.5	27	FORWARD
CHRA3756505A	5 ± 3	27	REVERSE
CHRA3756501A	1 ± 0.5	27	REVERSE

## INSTALLATION HOLE

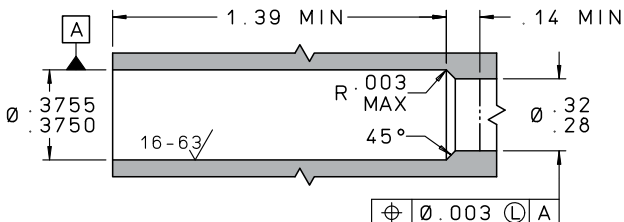

## INSTALLATION AND EXTRACTION

Tool Set Part Number ..... CUTA3750306C  
 Procedures ..... See **Pages N26 – N30**  
 Line Mount Configurations..... See **Pages L34 – L35,**  
**L40 – L41**

Replacement Pin Part Number..... PHRA3750003A

*For boss size see **page N24**. For oversize see **page N28**.*

## PERFORMANCE

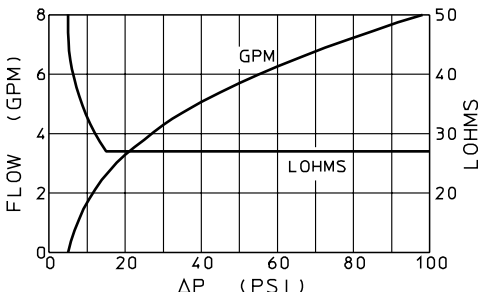

Cracking Pressure .....  $5 \pm 3$  or  $1 \pm 0.5$  psid  
 Maximum Leakage in ..... 1 drop/minute at 5 psid  
     checked direction ..... 1 drop/hour at 1000 - 8000 psid  
 Lohm rate at 15 psid and greater..... 27 Lohms Maximum  
 Nominal System Pressure ..... up to 8000 psi  
 Nominal Weight ..... 13 grams

*Valve performance on MIL-PRF-83282 at 85°F. 1 drop = 50  $\mu$ L*

PIN

INSERT

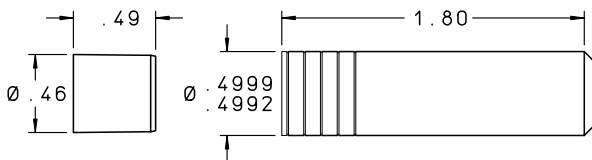

## MATERIALS

PART	MATERIAL	SPECIFICATION
Body	304 Cres	AMS 5639
Pin	15-5PH Cres	AMS 5659
Poppet	15-5PH Cres	AMS 5659
Spring	17-7PH Cres	AMS 5678
Spring Seat	303 Cres	QQ-S-763C

*Finish: All Cres Parts Passivated.*

*Pins are prewaxed. Do not degrease. Do not lubricate.*

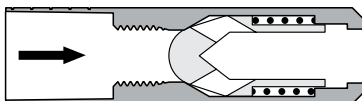

**CHFA5006505A • FREE FLOW FORWARD**

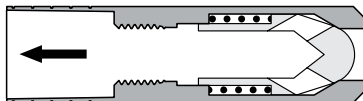

**CHRA5006505A • FREE FLOW REVERSE**

LEE PART NUMBER	CRACKING PRESSURE (psid)	LOHM RATE	FLOW DIRECTION
CHFA5006505A	5 ± 3	15	FORWARD
CHFA5006501A	1 ± 0.5	15	FORWARD
CHRA5006505A	5 ± 3	15	REVERSE
CHRA5006501A	1 ± 0.5	15	REVERSE

## INSTALLATION HOLE

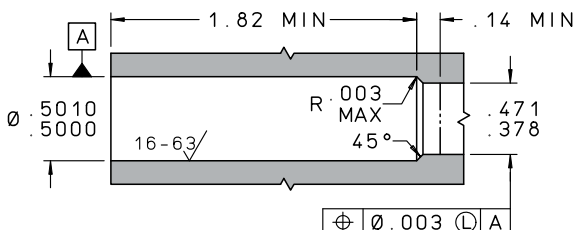

## INSTALLATION AND EXTRACTION

Tool Set Part Number .....	CUTA5000206C
Procedures .....	See <b>Pages N26 – N30</b>
Line Mount Configurations.....	See <b>Pages L34 – L35,</b> <b>L40 – L41</b>
Replacement Pin Part Number.....	CHFA5000003A

*For boss size see **page N24**. For oversize see **page N28**.*

## PERFORMANCE

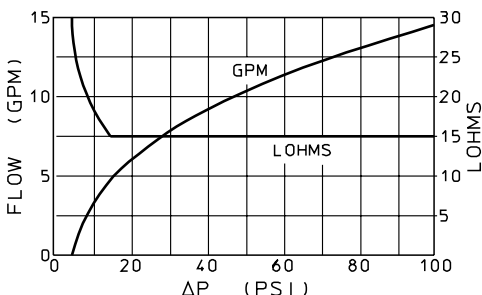

Cracking Pressure .....	$5 \pm 3$ or $1 \pm 0.5$ psid
Maximum Leakage in .....	1 drop/minute at 5 psid
checked direction	1 drop/hour at 1000 - 8000 psid
Lohm rate at 15 psid and greater.....	15 Lohms Maximum
Nominal System Pressure .....	up to 8000 psi
Nominal Weight .....	29 grams

*Valve performance on MIL-PRF-83282 at 85°F. 1 drop = 50  $\mu$ L*

PIN

INSERT

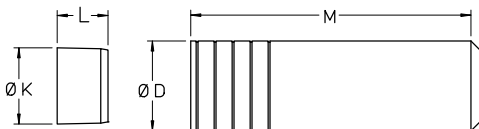

## MATERIALS

PART	MATERIAL
Body	MP35N
Poppet	MP35N
Spring	Elgiloy®
Pin	MP35N

*Finish: All Cres Parts Passivated.*

*Pins are prewaxed. Do not degrease. Do not lubricate.*

## DIMENSIONS

	.125" Dia.	.187" Dia.	.250" Dia.	.375" Dia.	.500" Dia.
Ø D	0.1242 - 0.1249	0.1867 - 0.1874	0.2492 - 0.2499	0.3742 - 0.3749	0.4992 - 0.4999
M	0.52	0.82	1.00	1.30	1.69
Ø K	0.11	0.16	0.21	0.34	0.46
L	0.14	0.25	0.32	0.39	0.49
A	0.54 min.	0.84 min.	1.02 min.	1.32 min.	1.71 min.
Ø N	0.082 - 0.096	0.141 - 0.159	0.205 - 0.221	0.280 - 0.320	0.378 - 0.445
Ø Ream	0.1250 - 0.1255	0.1875 - 0.1880	0.2500 - 0.2505	0.3750 - 0.3755	0.5000 - 0.5010

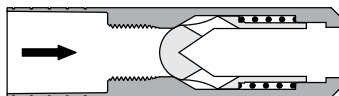

**FREE FLOW FORWARD**

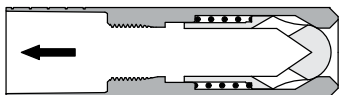

**FREE FLOW REVERSE**

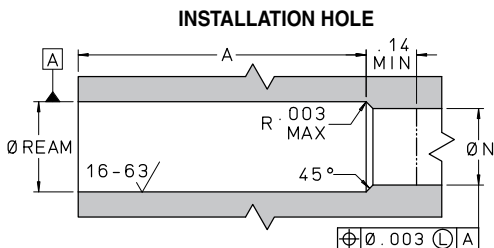

## INSTALLATION AND EXTRACTION

Procedures ..... See **Pages N26 – N30**

*For boss size see **page N24**. For oversize see **page N28**.*

# E

LEE PART NUMBER	CRACKING PRESSURE (psid)	LOHM RATE (Max.)	FLOW DIRECTION	MAXIMUM LEAKAGE CHECKED DIRECTION	MAX. WORKING PRESSURE* (psid)	
CHRA1256651A	1 ± 0.5	400	Reverse	1 drop/min at 5 psid	15,000	
CHRA1256655A	5 ± 3					
CHFA1256651A	1 ± 0.5		Forward	1 drop/hr at 1,000-15,000 psid		15,000*
CHFA1256655A	5 ± 3					
CHRA1876651A	1 ± 0.5	210	Reverse	1 drop/min at 5 psid	15,000	
CHRA1876655A	5 ± 3					
CHFA1876651A	1 ± 0.5		Forward	1 drop/hr at 1,000-15,000 psid		15,000*
CHFA1876655A	5 ± 3					
CHRA2506651A	1 ± 0.5	60	Reverse	1 drop/min at 5 psid	15,000	
CHRA2506655A	5 ± 3					
CHFA2506651A	1 ± 0.5		Forward	1 drop/hr at 1,000-15,000 psid		15,000*
CHFA2506655A	5 ± 3					
CHRA3756651A	1 ± 0.5	27	Reverse	1 drop/min at 5 psid	15,000	
CHRA3756655A	5 ± 3					
CHFA3756651A	1 ± 0.5		Forward	1 drop/hr at 1,000-15,000 psid		15,000*
CHFA3756655A	5 ± 3					
CHRA5006651A	1 ± 0.5	15	Reverse	1 drop/min at 5 psid	15,000	
CHRA5006655A	5 ± 3					
CHFA5006651A	1 ± 0.5		Forward	1 drop/hr at 1,000-15,000 psid		15,000*
CHFA5006655A	5 ± 3					

\* These forward flow check valve models require secondary retention for check direction pressure above 8,000 PSID.

PIN

INSERT

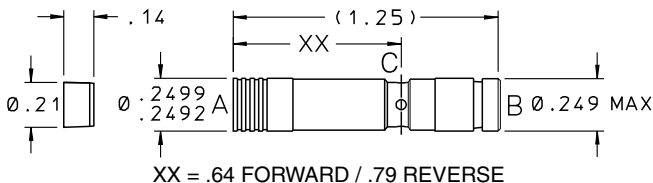

### MATERIALS

PART	MATERIAL	SPECIFICATION
Body	304 Cres	AMS 5639
Springs	17-7PH Cres	AMS 5678
Poppet	15-5PH Cres	AMS 5659
Pilot Piston	13-8 MO Cres	AMS 5629
Pin	17-4PH Cres	AMS 5643
Piston Seal	Teflon®	AMS 3656
Compression Seal	Polyamide-Imide	AMS 3670/1

*Finish: All Cres Parts Passivated.*

*Pins are prewaxed. Do not degrease. Do not lubricate.*

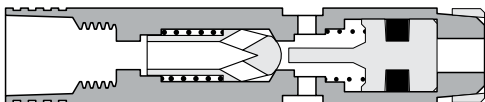
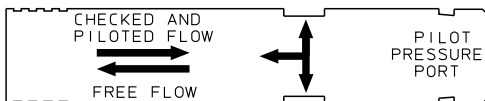

**CPRA2506005A • FREE FLOW REVERSE**

LEE PART NUMBER	(Port C to Port A) CRACKING PRESSURE (psid)	MIN. PILOT RATIO	(Port A to Port C) PILOTED LOHM RATE	FLOW DIRECTION
CPRA2506005A	5 ± 3	3:1	300	REVERSE
CPFA2506005A	5 ± 3	3:1	300	FORWARD

## INSTALLATION HOLE

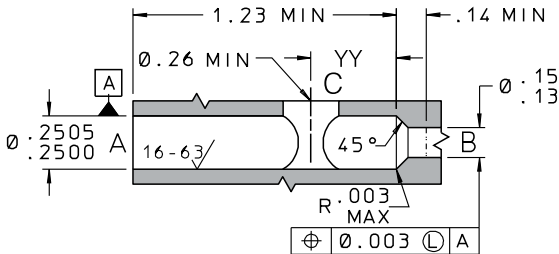

YY = .580 FORWARD / .400 REVERSE

E

## INSTALLATION AND EXTRACTION

Tool Set Part Number ..... CUTX0503050B  
 Procedures ..... See **Pages N26 – N30**  
 Replacement Pin Part Number ..... CKFA2500005A  
 Replacement Compression Seal ..... CPRA2500009A

*For boss size see **page N24**. For oversize see **page N28**.*

## PERFORMANCE

Cracking Pressure: (Port C to Port A, Port B at 0 psig) .....  $5 \pm 3$  psid  
 Minimum Pilot Ratio: (Port A Pressure/Port B Pressure,  
 Port C at 0 psig) ..... 3:1  
 Piloted Flow Rate: (Port A to Port C) ..... 300 Lohms Maximum  
 Leakage in Checked Direction: (Port A to Port C,  
 Port B at 0 psig) ..... 1 drop/minute Maximum at 5 psid  
 1 drop/hour Maximum at 1000 - 3000 psid  
 Pilot Piston Leakage: (Port B to Port A and Port C, Port A and  
 Port C at 0 psig) ..... 1 drop/minute Maximum at 3000 psid  
 Nominal System Pressure ..... up to 3000 psi  
 Nominal Weight ..... 5.3 grams

*Valve performance on MIL-PRF-83282 at 85°F. 1 drop = 50  $\mu$ L*



### INSTALLATION HOLE

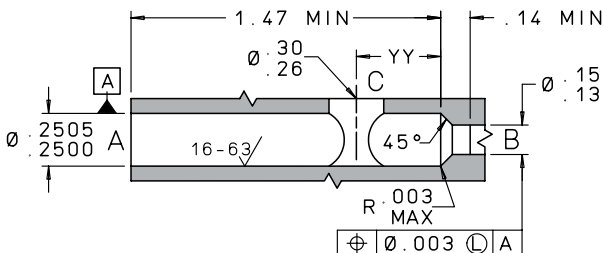

YY = .530 FORWARD / .430 REVERSE

E

### INSTALLATION AND EXTRACTION

Tool Set Part Number: ..... CUTX0503050B  
 Procedures:..... See **Pages N26 – N30**  
 Replacement Pin Part Number:..... CHFA2500003A  
 Replacement Compression Seal Part Number: ...CPRA2500109A  
 or CPRA2500009A

*For boss size see **page N24**. For oversize see **page N28**.*

LEE PART NUMBER	CRACKING PRESSURE (psid)	MIN. PILOT RATIO	PILOTED LOHM RATE	SEAL MATERIAL	FLOW DIRECTION
CPFA2507105A	5+/-3	3:1	300 Lohms maximum	Polyimide	Forward
CPRA2507105A	5+/-3	3:1	300 Lohms maximum	Polyimide	Reverse
CPFA2507005A	5+/-3	3:1	300 Lohms maximum	Polyamide-Imide	Forward
CPRA2507005A	5+/-3	3:1	300 Lohms maximum	Polyamide-Imide	Reverse

PIN

INSERT

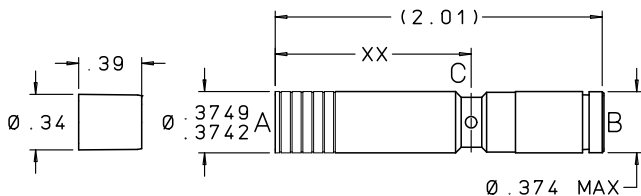

XX = 1.30 FORWARD / 1.20 REVERSE

E

## MATERIALS

PART	MATERIAL	SPECIFICATION
Body Front	304 Cres	AMS 5639
Body Center	15-5 PH Cres	AMS 5659
Body Rear	304 Cres	AMS 5639
Springs	17-7 PH Cres	AMS 5678
Poppet	15-5 PH Cres	AMS 5659
Pilot Piston	15-5 PH Cres	AMS 5659
Pin	17-4 PH Cres	AMS 5643
Compression Seal	Polyimide	—

*Finish: All Cres Parts Passivated.*

*Pins are prewaxed. Do not degrease. Do not lubricate.*

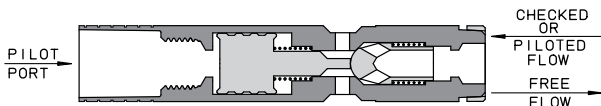

**FREE FLOW FORWARD**

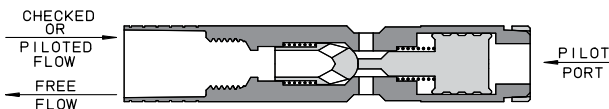

**FREE FLOW REVERSE**



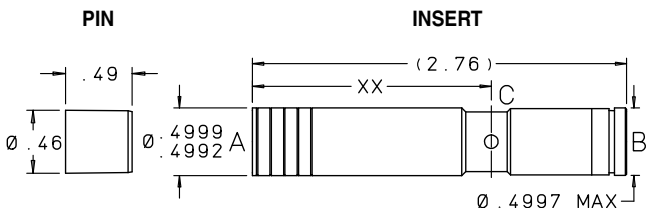

XX = 1.76 FORWARD / 1.68 REVERSE

E

MATERIALS		
PART	MATERIAL	SPECIFICATION
Body Front	304 Cres	AMS 5639
Body Center	15-5 PH Cres	AMS 5659
Body Rear	304 Cres	AMS 5639
Poppet	15-5PH Cres	AMS 5659
Springs	17-7PH Cres	AMS 5678
Pilot Piston	13-8MO Cres	AMS 5629
Pin	15-5 PH Cres	AMS 5659
Compression Seal	Polymer	—

*Finish: All Cres Parts Passivated.*

*Pins are prewaxed. Do not degrease. Do not lubricate.*

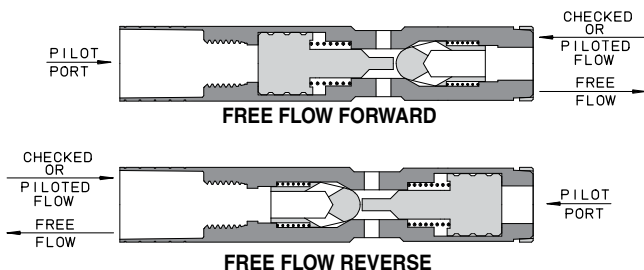

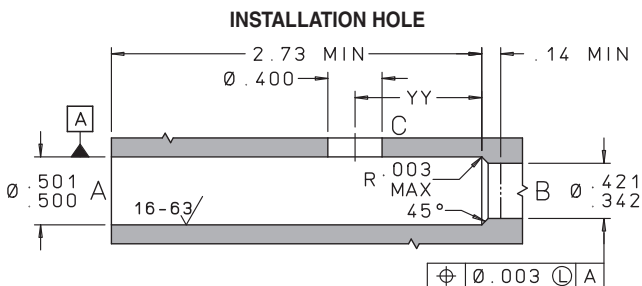

**INSTALLATION AND EXTRACTION**

Tool Set Part Number: ..... CUTA5000206C  
 Procedures:..... See **Pages N26 – N30**  
 Replacement Pin Part Number:..... CHFA5000003A  
 Replacement Compression Seal Part Number:..SVDS5000009A  
*For boss size see page N24. For oversize see **page N28.***

**PERFORMANCE**

Cracking Pressure: .....5 ± 3 psid  
 Minimum Pilot Ratio: ..... 3:1  
 Piloted Flow Rate: ..... 60 Lohms Maximum  
 Leakage in Checked Direction:..... 1 drop/minute at 5 psid  
 1 drop/hour at 1000 - 5000 psid  
 Pilot Piston Leakage:..... 1 drop/minute maximum at 5000 psid  
 Nominal System Pressure: ..... up to 5000 psi  
 Nominal Weight: ..... 49 grams  
*Valve performance on MIL-PRF-83282 at 85°F. 1 drop = 50 µL*

LEE PART NUMBER	CRACKING PRESSURE (psid)	MINIMUM PILOT RATIO	PILOTED LOHM RATE	FLOW DIRECTION
CPRA5007005A	5+/-3	3:1	60 Lohms maximum	Reverse
CPFA5007005A	5+/-3	3:1	60 Lohms maximum	Forward

# Relief Valves

F



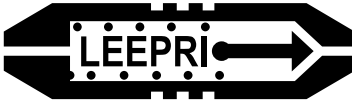

- High Capacity Miniature Inserts
- Available in Cracking Pressures from 20 - 5,900 psid
- Models Available for Low or High Flow Rates

F



- Optimized for Relieving Small Flows
- Low Leakage
- No Elastomers
- Available for 3,000, 4,000, and 5,000 psi Systems

**TABLE OF CONTENTS**

<b>187 PRI</b>	0.187" diameter miniature low pressure relief: 20-100 psid, 400-460 Lohms.....	<b>12 – 15</b>
<b>187 Zero Leak PRI</b>	0.187" diameter, no-leak safety relief: 20- 100 psid, 750 Lohms.....	<b>16 – 17</b>
<b>250 PRI</b>	0.250" diameter safety relief: 80-3,600 psid, 4500 Lohms .....	<b>18 – 19</b>
<b>281 PRI</b>	0.281" diameter safety relief: 80-3,600 psid, 220-280 Lohms .....	<b>20 – 27</b>
<b>687 PRV</b>	0.687" LRU safety relief: 400-3,600 psid, 230-350 Lohms .....	<b>28 – 29</b>
<b>281 High Pressure PRI</b>	0.281" diameter, high pressure relief: 3,000 - 5,900 psid, 1500 Lohms .....	<b>30 – 31</b>
<b>375 High Pressure PRI</b>	0.375" diameter high pressure relief for 3,000, 4,000 and 5,000 psi systems, 400 Lohms .....	<b>32 – 33</b>
<b>375 Momentum PRI</b>	0.375" diameter, low pressure, high flow relief: 50- 500 psid, 100 Lohms .....	<b>34 – 35</b>
<b>500 Momentum PRI</b>	0.500" diameter, low pressure, high flow relief: 50- 500 psid, 50 Lohms.....	<b>36 – 37</b>
<b>Hi-Q PRV</b>	0.812" LRU safety relief: 1,000-5,400 psid, 75-100 Lohms .....	<b>38 – 39</b>
<b>187 TRI</b>	0.187" diameter, thermal pressure relief for 3,000 and 4,000 psi systems.....	<b>40 – 41</b>
<b>250 High Pressure TRI</b>	0.250" diameter high pressure thermal pressure relief for up to 5,000 psi systems .....	<b>42 – 43</b>
<b>281 Zero Leak PRI</b>	0.281" diameter, no-leak safety relief: 800-4,700 psid, 100,000 Lohms .....	<b>44 – 45</b>

## SELECTING A RELIEF VALVE

Lee relief valves come in a wide range of styles. Each style has been developed to satisfy specific relief needs commonly found in hydraulic systems. Safety relief valves are designed to be exercised for intermittent “pop off” applications. Pressure regulating valves are intended to operate more continuously with stable performance throughout the operating range. Thermal relief valves relieve a few droplets of fluid from a trapped volume expanding due to rising temperatures. Because these applications are very different, it is important that the correct valve is selected to ensure proper functioning of the system.

## SELECTION CRITERIA

Selection criteria should first be based on the minimum cracking and shutoff pressures, followed by the Lohm rate at the relief flow point (calculated from the relief flow rate and differential pressure using the Lohm law). Packaging style, integral screening requirements, allowable leakage rates, flow direction, etc. are other selection criteria that should then be considered. For most applications, the minimum cracking pressure should be high enough such that the relief valve will remain closed under the normal operating pressure and the Lohm rate at the relief flow pressure will be sufficient to protect the system from over-pressurization. The minimum shutoff pressure should then be high enough to allow the valve to close once the operating pressure returns to normal. The final selection involves matching the valve’s operating characteristics with the desired function in the hydraulic system.

## SAFETY RELIEF VALVES

### 187 and 187 Zero Leak PRI

The 187 PRI valve is specifically designed to be the smallest valve available for safety relief applications

with system pressures up to 3,000 psi. It is constructed entirely of stainless steel and is available screened and unscreened, in forward and reverse relief flow directions, for design flexibility. Built-in damping assures quiet operation. At only three sixteenths of an inch in diameter and a little over a half inch long, the 187 PRI covers cracking pressures from 20 to 100 psid.

The 187 Zero Leak PRI is designed to be comparable to the 187 PRI in performance, but with elastomer seat materials to provide zero leakage performance when closed. It is offered in both forward and reverse directions with either a Fluorocarbon or EPDM seat for fluid compatibility considerations.

F

### **250 and 281 PRI**

The 250 and 281 PRI valves are specifically designed for safety relief applications with system pressures up to 3,000 psi. Both are constructed entirely of stainless steel and are available screened and unscreened, in forward and reverse relief flow directions, for design flexibility. Built-in damping assures quiet operation. Both the 250 and 281 PRIs offer standard cracking pressures from 80 to 3,600 psid.

The 281 PRI valves are also available in corrosion-resistant materials that are compliant with NACE specification MRO175 / ISO 15156.

### **687 Threaded PRV**

The 687 Threaded PRV takes the proven design of the Lee 281 PRI and packages it in a Line Removable Unit (LRU) for ease of installation and extraction. The threaded cartridge is designed to be installed in a standard SAE AS 5551-10 installation hole. The valve is designed for axial inlet, side exit operation and is available in both screened and unscreened versions for use in 3,000 psi systems. Standard cracking pressures range from 400 to 3,600 psid.

## **281 and 375 High Pressure PRI**

The High Pressure PRI valve is designed for safety relief applications where operating pressures and pressure spikes are severe enough to structurally damage conventional safety relief valves. The 281 High Pressure PRI valve's rugged design includes 440C stainless steel and tungsten carbide sealing surface materials, making it durable enough to operate in 5,000 psi systems and beyond. The 281 High Pressure PRI is also available in corrosion resistant materials that are compliant with NACE specification MRO175 / ISO 15166.

The 375 High Pressure PRI is a safety relief valve that offers a higher flow capacity than the 281 High Pressure PRI, and is also durable enough to operate in 5,000 systems. This relief valve has also shown stable relief flow performance in applications with back pressures up to 850 psig. It features a durable tungsten carbide ball with the remaining components constructed entirely of stainless steel. Available in forward and reverse relief flow directions, the 281 and 375 High Pressure PRIs offer a range of standard cracking pressures for 3,000, 4,000 and 5,000 psi systems with system proof pressures up to 7,500 psi.

**F**

## **PRESSURE REGULATING RELIEF VALVES**

### **375 and 500 Momentum PRI**

The 375 and 500 Pressure Relief Valves use the patented "momentum free" design concept, making them ideal for pressure regulating applications. The unique design compensates for momentum forces that upset the normal force balance of typical direct acting valves. These forces are produced by local pressure gradients caused by changes in liquid velocity (see "Momentum Forces" on [page O22](#)). The result is a valve that is stable throughout the operating range and

open, flow capacity of 100 Lohms and the 500 PRI has a 50 Lohm capacity. Both are available in standard cracking pressures from 50 to 500 psid.

### **Hi-Q PRV**

The Hi-Q threaded Pressure Relief Valve is designed for applications that require both a high relief pressure and a high flow rate in a compact, Line Removable Unit. The threaded cartridge is designed to be installed in a standard SAE AS 5551-12 installation hole providing side inlet, axial exit, operation. The valve is suitable for use in applications with system pressures up to 5,000 psi and is available with standard cracking pressures ranging from 1,000 to 5,400 psid.

F

## **THERMAL RELIEF VALVES**

### **187 TRI and 250 High Pressure TRI**

The Lee TRI Thermal Relief Valve has been designed to relieve fluid pressure caused by thermal expansion. When a sealed container is completely filled with fluid, thermal expansion can cause container rupture or seal failure. The Lee TRI eliminates this hazard.

Because many systems need to relieve only a few drops of fluid to return to their design pressure, the Lee 187 TRI has been optimized for relieving low flow rates. A high Lohm rate restrictor is used in series with a relief valve to limit the flow rate. This restricts the flow rate sufficiently to ensure shutoff above system pressure. A ceramic ball and seat material provides the toughness and dimensional stability needed for a tight shutoff leakage performance. The incorporation of an integral 15µm Cres filter upstream of the valve seat prevents internal silting due to ingested contamination. Excess total flow through the valve may cause clogging of this integral filter, therefore, the Lee TRI is not recommended for general pressure relief service.

Lee also offers a 250 High Pressure TRI that is a blend of the 281 High Pressure PRI and 187 TRI technologies. This valve is intended for thermal relief applications where the thermal relief valve will experience severe pressure spikes or pressure change rates not typical of a thermal event. The valve's tight hysteresis and rugged design make it the preferred selection for these types of applications.

## 281 Zero Leak PRI

The 281 Zero Leak PRI is designed to provide a system the protection of thermal relief or low flow pressure relief, with the additional feature of zero leakage performance when closed. Standard cracking pressures ranging from 800 to 4,700 psid make it suitable for use in applications with system pressures up to 4,000 psi. Although standard performance is rated to 100,000 Lohms for thermal relief applications, the design is capable of providing lower Lohm rates for low flow, general relief applications.

**F**

## ADDITIONAL CONSIDERATIONS FOR THERMAL PRESSURE RELIEF

When selecting a thermal relief valve, several factors need to be considered. These factors include the closed volume the valve is intended to protect, the rate of temperature change, the minimum temperature the valve will be exposed to, the type of fluid being used, the initial pressure and the ultimate pressure a vessel can withstand, etc. To assist in selecting the correct performance requirements, the formulas and tables from [pages O24 – O25](#) can be applied to calculate the increase in pressure due to a temperature increase in a closed volume or the increase in fluid volume due to a temperature increase. The flow rate needed to

maintain the same volume with a temperature increase can then be determined:

$$Q = V \times \gamma \times \frac{\Delta T}{\Delta t}$$

Where

Q = flow rate

$\frac{\Delta T}{\Delta t}$  = the rate of temperature increase

The Nomogram on [page F9](#) can also be used to graphically determine the necessary flow rate to protect a closed volume. Although created for use with Skydrol 500B-4, it can also be used for any fluid with a similar coefficient of cubical thermal expansion.

For example, a 1000 inch<sup>3</sup> closed volume of Skydrol 500B-4 will see a temperature increase from -65°F to -40°F in 10 minutes. A thermal relief valve will need to relieve 19 ml/min of fluid as the temperature increases to prevent an increase in pressure within the closed volume.

$$Q = 1000 \times 0.00047 \times \frac{25}{10} = 1.18 \text{ inches}^3/\text{min} \text{ or approximately } 19 \text{ ml/min}$$

Note, if the minimum operating temperature of the system is -65°F, the thermal relief valve does not need to relieve 19 ml/min at -65°F. It is only as the temperature increases does the valve need to relieve fluid.

Compare the calculated flow rate above with the flow at the relief flow point for a TRI valve with a suitable cracking pressure (see Table on [page F40](#) or [F42](#)). If the calculated flow rate is less than the one shown in the table, the Lee TRI will limit thermally induced pressure in your system to no more than the rated relief flow pressure. Based on the above example, a 250 HP TRI or 281 Zero Leak PRI would provide a sufficient flow rate.

## LEE TRI FLOW NOMOGRAM FOR SKYDROL 500 OR MIL-H-5606 AT 100°F

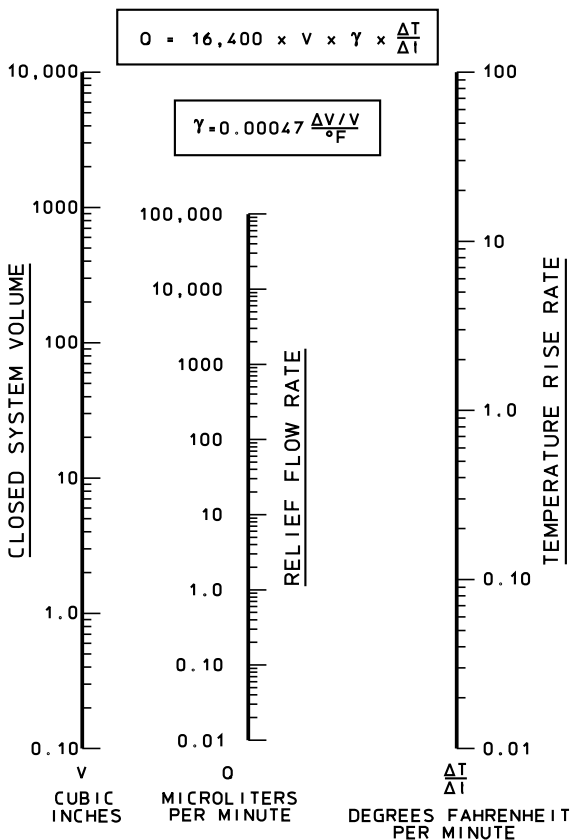

The following chart shows the standard cracking pressure ranges and relief flow Lohm rates available for various Lee relief valves. First, locate the relief valves that provide the required cracking pressure within their range. Next, choose the relief valve with the closest Lohm rate that is less than the required amount.

For example, a safety relief valve with a cracking pressure of 200 psid is needed with a Lohm rate of 110 Lohms at the relief flow pressure. Using the chart, it is apparent the 250, 281, 375 Momentum, and 500 Momentum PRI valves provide the necessary cracking pressure. The 375 Momentum PRI has the Lohm rate that is the closest and is less than the required amount. The 375 Momentum PRI is the relief valve that should be chosen for the application.

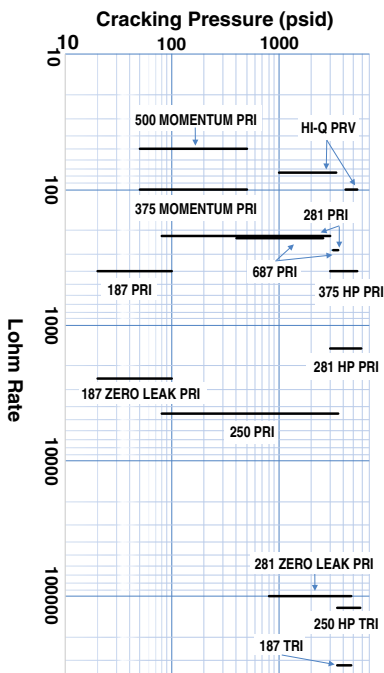

The principal characteristics of each relief valve type are tabulated below.

## CHARACTERISTICS

VALVE TYPE	TYPICAL APPLICATIONS	PRES. BAND* %	LOHMS AT MIN. VALVE LIFT**	SUITABLE FOR		
				SAFETY RELIEF	PRESSURE REGULATING	THERMAL PRESSURE RELIEF
187 PRI	1) General low pressure relief 2) Pressure Regulating 3) As a check valve	40	1500	Yes	Yes	No
187 Zero Leak PRI	1) General low pressure relief with zero leakage	–	–	Yes	No	No
250 PRI	1) General relief 2) Cross port load alleviation	–	Yes	Yes	No	No
281 PRI	1) General relief 2) Cross port load alleviation	40	1500	Yes	No	No
687 PRV	1) General relief 2) Cross port load alleviation 3) Line Removable	40	1500	Yes	No	No
281 HP PRI	1) General high pressure relief	25	–	Yes	No	No
375 HP PRI	1) General high pressure relief	28	1500	Yes	No	No
375 Momentum PRI	1) Filter by-pass relief 2) Lubrication systems 3) Fuel systems	35	500	Yes	Yes	No
500 Momentum PRI	1) Filter by-pass relief 2) Lubrication systems 3) Fuel systems	35	350	Yes	Yes	No
HI-Q PRV	1) General high pressure relief with high flow rate	–	–	Yes	Yes	No
187 TRI	1) Thermal pressure relief	25	Not Limited	No	No	Yes
250 High Pressure TRI	1) High pressure thermal pressure relief	25	Not Limited	No	No	Yes
281 Zero Leak PRI	1) Thermal pressure relief with zero leakage 2) General relief with low flow rate	–	–	Yes	No	Yes

\* Pressure Band defined as:  $\frac{\text{pressure at flow point} - \text{pressure at shutoff}}{\text{cracking pressure}}$

\*\* Lohms at minimum valve lift is derived from the minimum valve opening necessary to avoid silting.

PIN

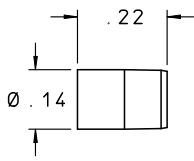

INSERT

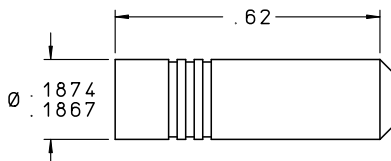

### MATERIALS

PART	MATERIAL	SPECIFICATION
Body	303 Cres	QQ-S-763C
Pin	17-4PH Cres	AMS 5643
Spring	17-7PH Cres	AMS 5678
Ball	440C Cres	AMS 5630
Cage	303 Cres	QQ-S-763C
Spring Seat	303 Cres	QQ-S-763C
Ball Follower	303 Cres	QQ-S-763C

*Finish: All Cres Parts Passivated.*

*Pins are prewaxed. Do not degrease. Do not lubricate.*

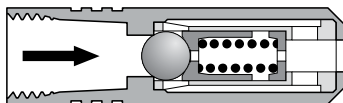

PRFA1872020L • RELIEF FLOW FORWARD

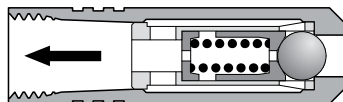

PRRA1872020L • RELIEF FLOW REVERSE

LEE PART NUMBER		CRACKING PRESSURE (psid)
FORWARD	REVERSE	
PRFA1872020L	PRRA1872020L	20
PRFA1872040L	PRRA1872040L	40
PRFA1872060L	PRRA1872060L	60
PRFA1872080L	PRRA1872080L	80
PRFA1872100L	PRRA1872100L	100

## INSTALLATION HOLE

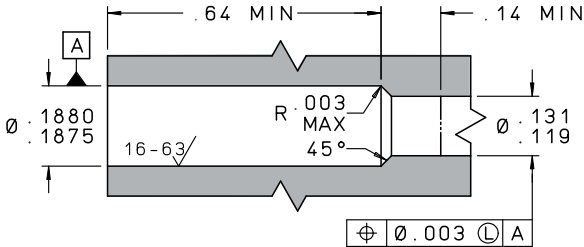

## INSTALLATION AND EXTRACTION

Tool Set Part Number ..... CUTA1870104C  
 Procedures ..... See **Pages N26 – N30**  
 Line Mount Configurations..... See **Pages L6 – L8**  
 Replacement Pin Part Number..... JETA1870004A

*For boss size see **page N24**. For oversize see **page N28**.*

## PERFORMANCE

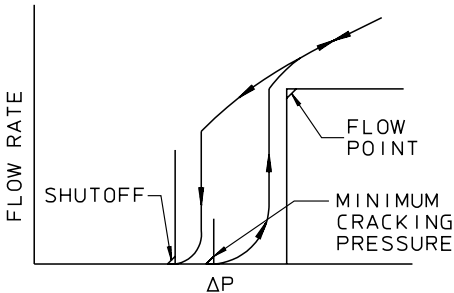

Tolerance on Cracking Pressure .....  $\pm 10\%$   
 Full Open Lohm Rate..... 400 Lohms (max.)  
 Lohm Rate at 125% of Actual Crack..... 1100 Lohms (max.)  
 Restriction at Min. Recommended Valve Lift... 1500 Lohms (max.)  
 Reseat Leakage (90% of Actual Crack.)..... 10 drops/min. (max.)  
 Shutoff Leakage (85% of Actual Crack.)..... 10 drops/hour (max.)  
 Nominal System Pressure..... up to 3000 psi  
 Nominal Weight ..... 1.5 grams

*Valve performance on MIL-PRF-83282 at 85°F. 1 drop = 50  $\mu$ L*

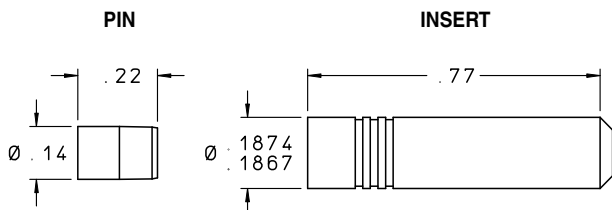

### MATERIALS

PART	MATERIAL	SPECIFICATION
Body	303 Cres	QQ-S-763C
Pin	17-4PH Cres	AMS 5643
Spring	17-7PH Cres	AMS 5678
Ball	440C Cres	AMS 5630
Screen	304L Cres	ASTM A 666
Braze	—	AMS 4774
Cage	303 Cres	QQ-S-763C
Spring Seat	303 Cres	QQ-S-763C
Ball Follower	303 Cres	QQ-S-763C

*Finish: All Cres Parts Passivated.*

*Pins are prewaxed. Do not degrease. Do not lubricate.*

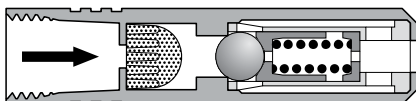

**PRFA1875020L • RELIEF FLOW FORWARD**

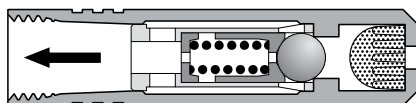

**PRRA1875020L • RELIEF FLOW REVERSE**

LEE PART NUMBER		CRACKING PRESSURE (psid)	SCREEN HOLE SIZE (Inches)
FORWARD	REVERSE		
PRFA1875020L	PRRA1875020L	20	0.008
PRFA1875040L	PRRA1875040L	40	0.008
PRFA1875060L	PRRA1875060L	60	0.008
PRFA1875080L	PRRA1875080L	80	0.008
PRFA1875100L	PRRA1875100L	100	0.008

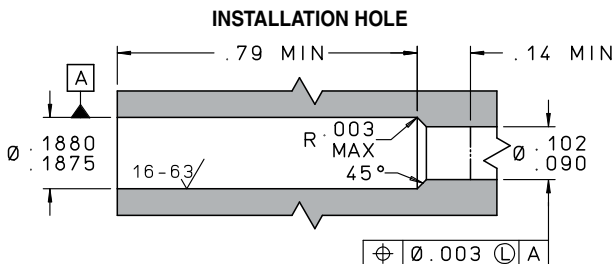

## INSTALLATION AND EXTRACTION

Tool Set Part Number ..... CUTA1870104C  
 Procedures ..... See **Pages N26 – N30**  
 Line Mount Configurations..... See **Pages L6 – L8**  
 Replacement Pin Part Number..... JETA1870004A

*For boss size see **page N24**. For oversize see **page N28**.*

## PERFORMANCE

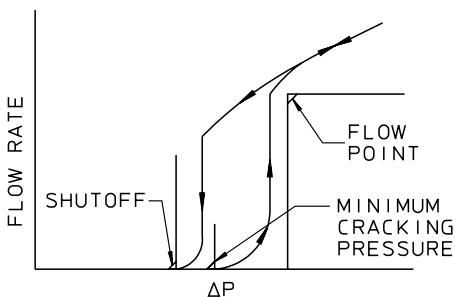

Tolerance on Cracking Pressure .....  $\pm 10\%$   
 Full Open Lohm Rate ..... 460 Lohms (max.)  
 Lohm Rate at 125% of Actual Crack. .... 1500 Lohms (max.)  
 Restriction at Min. Recommended Valve Lift.... 1500 Lohms (max.)  
 Reseat Leakage (90% of Actual Crack.) ..... 10 drops/min.(max.)  
 Shutoff Leakage (85% of Actual Crack.) ..... 10 drops/hour (max.)  
 Screen Hole Size ..... 0.008" Nominal  
 Nominal System Pressure..... up to 3000 psi  
 Nominal Weight ..... 1.7 grams  
*Valve performance on MIL-PRF-83282 at 85°F. 1 drop = 50  $\mu$ L*

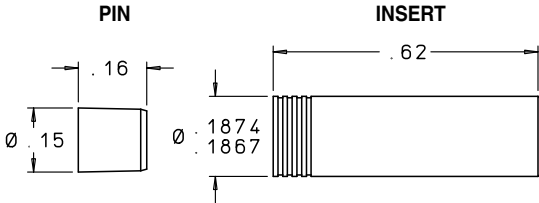

## MATERIALS

PART	MATERIAL	SPECIFICATION
Body	15-5PH Cres	AMS 5659
Poppet	303 Cres	QQ-S-763C
Spring	17-7PH Cres	AMS 5678
Optional Shims	300 Series Cres	ASTM A 666
Pin	17-4PH Cres	AMS 5643
Elastomeric Seat <i>Each valve contains one of the following elastomeric materials.</i>	Fluorocarbon	AMS-R-83485 or AMS-R-83248
	EPDM	AMS-R-83285

*Finish: All Cres Parts Passivated.*

*Pins are prewaxed. Do not degrease. Do not lubricate.*

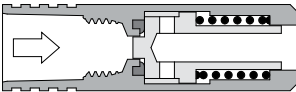

**RELIEF FLOW FORWARD**

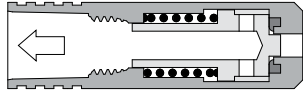

**RELIEF FLOW REVERSE**

## PERFORMANCE

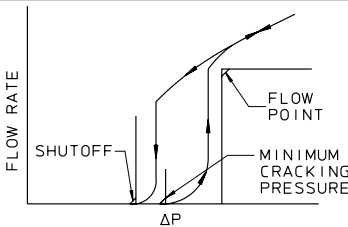

Leakage at Minimum Cracking Pressure:..... 0 drops in a 1 minute test

Leakage at Minimum Shutoff Pressure: ..... 0 drops in a 1 minute test

Nominal Weight:..... 1.5 grams

*Valve performance on Hydraulic Oil at ambient temperature.*

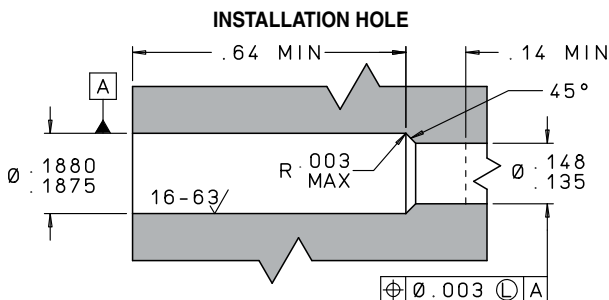

### INSTALLATION AND EXTRACTION

Tool Set Part Number ..... CUTA1870110C  
 Procedures ..... See **Pages N26 – N30**  
 Replacement Pin Part Number ..... CSFA1870003A  
*For boss size see **page N24**. For oversize see **page N28**.*

LEE PART NUMBER		SEAT MATERIAL	MIN. CRACKING PRESSURE (psid)	FLOW POINT		FULLY OPEN LOHM RATE	MIN. SHUT-OFF PRESSURE (psid)
FORWARD	REVERSE			LOHM RATE	AT (psid)		
PSFA1870020L	PSRA1870020L	Fluorocarbon	20	2500 max.	40	750 max.	16
PSFA1870040L	PSRA1870040L	Fluorocarbon	40	2500 max.	80	750 max.	32
PSFA1870060L	PSRA1870060L	Fluorocarbon	60	2500 max.	105	750 max.	48
PSFA1870080L	PSRA1870080L	Fluorocarbon	80	2500 max.	140	750 max.	64
PSFA1870100L	PSRA1870100L	Fluorocarbon	100	2500 max.	175	750 max.	80
PSFA1871020L	PSRA1871020L	EPDM	20	2500 max.	40	750 max.	16
PSFA1871040L	PSRA1871040L	EPDM	40	2500 max.	80	750 max.	32
PSFA1871060L	PSRA1871060L	EPDM	60	2500 max.	105	750 max.	48
PSFA1871080L	PSRA1871080L	EPDM	80	2500 max.	140	750 max.	64
PSFA1871100L	PSRA1871100L	EPDM	100	2500 max.	175	750 max.	80

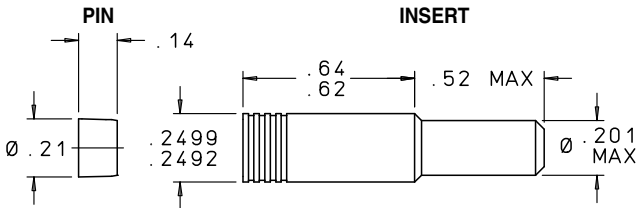

### MATERIALS

PART	MATERIAL	SPECIFICATION
Body Front	304 Cres	AMS 5639
Body Rear	304 Cres	AMS 5639
Pin	17-4PH Cres	AMS 5643
Poppet	15-5PH Cres	AMS 5659
Tube	304 Cres	AMS 5639
Spring Seat	304 Cres	AMS 5639
Spring	17-7PH Cres	AMS 5678
Screen	304L Cres	ASTM A 666
Braze	—	AMS 4774

*Finish: All Cres Parts Passivated.*

*Pins are prewaxed. Do not degrease. Do not lubricate.*

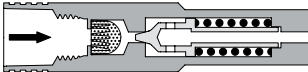

**RELIEF FLOW FORWARD**

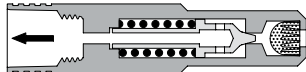

**RELIEF FLOW REVERSE**

LEE PART NUMBER		MINIMUM CRACKING PRESSURE (psid)	FLOW POINT			MINIMUM SHUTOFF PRESSURE (psid)
FORWARD	REVERSE		LOHM RATE	MIN. FLOW (gpm)	AT (psid)	
PRFA2505080L	PRRA2505080L	80	4500	0.08	300	72
PRFA2505500L	PRRA2505500L	500	4500	0.13	750	450
PRFA2505100D	PRRA2505100D	1000	4500	0.19	1500	900
PRFA2505120D	PRRA2505120D	1200	4500	0.20	1700	1080
PRFA2505140D	PRRA2505140D	1400	4500	0.21	1900	1260
PRFA2505220D	PRRA2505220D	2200	4500	0.25	2700	1980
PRFA2505250D	PRRA2505250D	2500	4500	0.27	3000	2250
PRFA2505300D	PRRA2505300D	3000	4500	0.29	3500	2700
PRFA2505320D	PRRA2505320D	3200	4500	0.29	3700	2880
PRFA2505340D	PRRA2505340D	3400	4500	0.30	3900	3060
PRFA2505350D	PRRA2505350D	3500	4500	0.31	4000	3150
PRFA2505360D	PRRA2505360D	3600	4500	0.31	4100	3240

## INSTALLATION HOLE

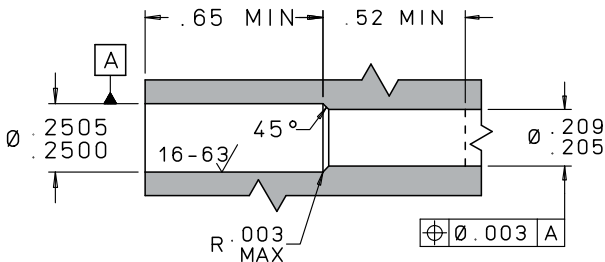

## INSTALLATION AND EXTRACTION

Tool Set Part Number ..... CUTA2500306C  
 Procedures ..... See **Pages N26 – N30**  
 Line Mount Configurations..... See **Page L7**  
 Replacement Pin Part Number..... CKFA250000SA

*For boss size see **page N24**. For oversize see **page N28**.*

**F**

## PERFORMANCE

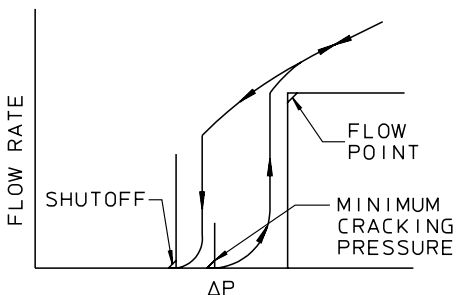

Leakage at Minimum Cracking Pressure: ..... 2 mL/minute (max.)

Leakage at Minimum Shutoff Pressure: ..... 2 mL/minute (max.)

Nominal System Pressure:..... Up to 3000 psi

System Peak Pressure:..... 4100 psi (max.)

Screen Hole Size:..... 0.008" Nominal

Screen Open Area: ..... 0.014 in<sup>2</sup> Nominal

*Valve performance on MIL-PRF-83282 or MIL-PRF-5606 at 85°F ±15°F*

PIN

INSERT

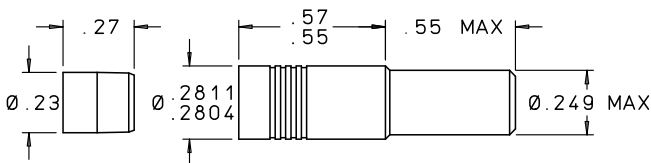

### MATERIALS

PART	MATERIAL	SPECIFICATION
Body	303 Cres	QQ-S-763C
Pin	303 Cres	QQ-S-763C
Tube	304 Cres	AMS 5639
Spring	17-7PH Cres	AMS 5678
Ball	440C Cres	AMS 5630
Ball Follower	303 Cres	QQ-S-763C
Spring Seat	303 Cres	QQ-S-763C

*Finish: All Cres Parts Passivated.*

*Pins are prewaxed. Do not degrease. Do not lubricate.*

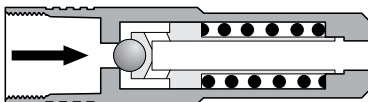

**PRFA2812080L • RELIEF FLOW FORWARD**

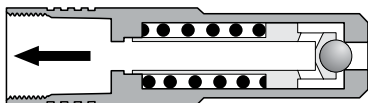

**PRRA2812080L • RELIEF FLOW REVERSE**

See [pages F22-F23](#) for performance data and part numbers.

## INSTALLATION HOLE

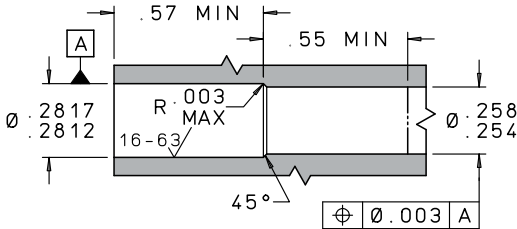

## INSTALLATION AND EXTRACTION

Tool Set Part Number ..... CUTA2810114C  
 Procedures ..... See **Pages N26 – N30**  
 Line Mount Configurations..... See **Pages L9 – L12**  
 Replacement Pin Part Number..... PRFA2810003A

*For boss size see **page N24**. For oversize see **page N28**.*

**F**

## PERFORMANCE

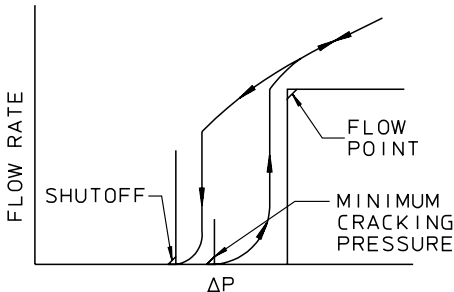

Leakage at Minimum Cracking Pressure ... 1 drop/minute (max.)  
 Leakage at Shutoff..... 20 drops/minute (max.)  
 Restriction at Minimum Recommended  
 Valve Lift..... 1500 Lohms (max.)  
 Nominal System Pressure..... up to 3000 psi  
 System Peak Pressure..... 5000 psi (max.)  
 Nominal Weight ..... 4.5 grams

*Valve performance on MIL-PRF-83282 at 85°F. 1 drop = 50  $\mu\text{L}$*

LEE PART NUMBER		MINIMUM CRACKING PRESSURE (psid)
FORWARD	REVERSE	
PRFA281*080L	PRRA281*080L	80
PRFA281*120L	PRRA281*120L	120
PRFA281*200L	PRRA281*200L	200
PRFA281*300L	PRRA281*300L	300
PRFA281*400L	PRRA281*400L	400
PRFA281*500L	PRRA281*500L	500
PRFA281*600L	PRRA281*600L	600
PRFA281*700L	PRRA281*700L	700
PRFA281*800L	PRRA281*800L	800
PRFA281*900L	PRRA281*900L	900
PRFA281*100D	PRRA281*100D	1000
PRFA281*110D	PRRA281*110D	1100
PRFA281*120D	PRRA281*120D	1200
PRFA281*140D	PRRA281*140D	1400
PRFA281*160D	PRRA281*160D	1600
PRFA281*180D	PRRA281*180D	1800
PRFA281*200D	PRRA281*200D	2000
PRFA281*220D	PRRA281*220D	2200
PRFA281*240D	PRRA281*240D	2400
PRFA281*250D	PRRA281*250D	2500
PRFA281*260D	PRRA281*260D	2600
PRFA281*280D	PRRA281*280D	2800
PRFA281*300D	PRRA281*300D	3000
PRFA281*310D	PRRA281*310D	3100
PRFA281*320D	PRRA281*320D	3200
PRFA281*330D	PRRA281*330D	3300
PRFA281*340D	PRRA281*340D	3400
PRFA281*350D	PRRA281*350D	3500
PRFA281*360D	PRRA281*360D	3600

\* Materials:

2 = Stainless Steel

\* Materials:

9 = NACE Compliant

FLOW POINT MIL-H-83282			MINIMUM SHUTOFF PRESSURE (psid)	MIN. RECOMMENDED VALVE LIFT	
MAX. LOHM RATE	MIN. GPM	AT (psid)		MAX. LOHMS	MIN. GPM
220	0.9	100	68	1500	0.2
220	1.1	150	100	1500	0.2
220	1.5	250	170	1500	0.3
220	1.8	375	255	1500	0.3
220	2.1	500	340	1500	0.4
220	2.4	625	425	1500	0.4
220	2.6	750	510	1500	0.4
220	2.8	875	595	1500	0.5
220	3.0	1000	680	1500	0.5
220	3.2	1125	765	1500	0.5
220	3.4	1250	850	1500	0.5
220	3.5	1375	935	1500	0.6
220	3.7	1500	1020	1500	0.6
220	4.0	1750	1190	1500	0.6
220	4.3	2000	1360	1500	0.7
220	4.5	2250	1530	1500	0.7
220	4.8	2500	1700	1500	0.8
220	5.0	2750	1870	1500	0.8
220	5.2	3000	2040	1500	0.8
220	5.4	3125	2125	1500	0.8
220	5.5	3250	2210	1500	0.9
220	5.7	3500	2380	1500	0.9
220	5.9	3750	2550	1500	0.9
280	4.7	3875	2635	1500	0.9
280	4.8	4000	2720	1500	0.9
280	4.9	4125	2805	1500	1.0
280	5.0	4250	2890	1500	1.0
280	5.0	4375	2975	1500	1.0
280	5.1	4500	3060	1500	1.0

**PIN**

**INSERT**

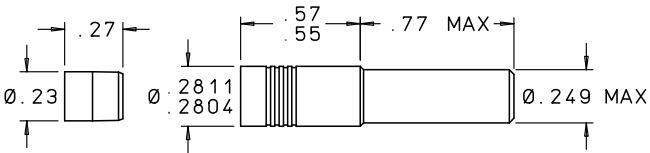

## MATERIALS

PART	MATERIAL	SPECIFICATION
Body	303 Cres	QQ-S-763C
Pin	303 Cres	QQ-S-763C
Tube	304 Cres	AMS 5639
Spring	17-7PH Cres	AMS 5678
Ball	440C Cres	AMS 5630
Screen	304L Cres	ASTM A 666
Braze	—	AMS 4774
Ball Follower	303 Cres	QQ-S-763C
Spring Seat	303 Cres	QQ-S-763C

*Finish: All Cres Parts Passivated.*

*Pins are prewaxed. Do not degrease. Do not lubricate.*

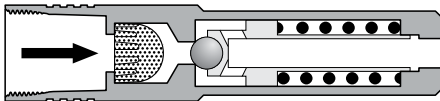

**PRFA2815080L • RELIEF FLOW FORWARD**

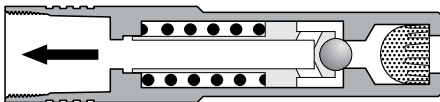

**PRRA2815080L • RELIEF FLOW REVERSE**

See [pages F26-F27](#) for performance data and part numbers.

## INSTALLATION HOLE

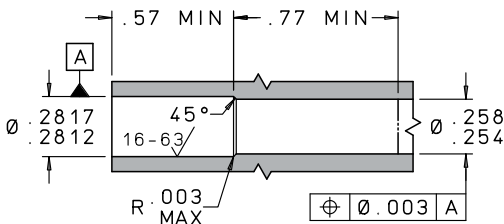

## INSTALLATION AND EXTRACTION

Tool Set Part Number ..... CUTA2810114C  
 Procedures ..... See [Pages N26 – N30](#)  
 Line Mount Configurations..... See [Pages L9 – L12](#)  
 Replacement Pin Part Number..... PRFA2810003A

For boss size see [page N24](#). For oversize see [page N28](#).

## PERFORMANCE

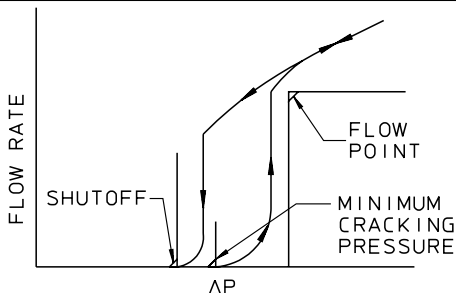

Leakage at Minimum Cracking Pressure ... 1 drop/minute (max.)  
 Leakage at Shutoff..... 20 drops/minute (max.)  
 Restriction at Minimum Recommended  
   Valve Lift ..... 1500 Lohms (max.)  
 Screen Hole Size..... 0.008" Nominal  
 Nominal System Pressure..... up to 3000 psi  
 System Peak Pressure..... 5000 psi (max.)  
 Nominal Weight ..... 6.0 grams

Valve performance on MIL-PRF-83282 at 85°F. 1 drop = 50  $\mu$ L

LEE PART NUMBER		MINIMUM CRACKING PRESSURE (psid)
FORWARD	REVERSE	
PRFA281*080L	PRRA281*080L	80
PRFA281*120L	PRRA281*120L	120
PRFA281*200L	PRRA281*200L	200
PRFA281*300L	PRRA281*300L	300
PRFA281*400L	PRRA281*400L	400
PRFA281*500L	PRRA281*500L	500
PRFA281*600L	PRRA281*600L	600
PRFA281*700L	PRRA281*700L	700
PRFA281*800L	PRRA281*800L	800
PRFA281*900L	PRRA281*900L	900
PRFA281*100D	PRRA281*100D	1000
PRFA281*110D	PRRA281*110D	1100
PRFA281*120D	PRRA281*120D	1200
PRFA281*140D	PRRA281*140D	1400
PRFA281*160D	PRRA281*160D	1600
PRFA281*180D	PRRA281*180D	1800
PRFA281*200D	PRRA281*200D	2000
PRFA281*220D	PRRA281*220D	2200
PRFA281*240D	PRRA281*240D	2400
PRFA281*250D	PRRA281*250D	2500
PRFA281*260D	PRRA281*260D	2600
PRFA281*280D	PRRA281*280D	2800
PRFA281*300D	PRRA281*300D	3000
PRFA281*310D	PRRA281*310D	3100
PRFA281*320D	PRRA281*320D	3200
PRFA281*330D	PRRA281*330D	3300
PRFA281*340D	PRRA281*340D	3400
PRFA281*350D	PRRA281*350D	3500
PRFA281*360D	PRRA281*360D	3600

\* Materials:

5 = Stainless Steel

\* Materials:

7 = NACE Compliant

FLOW POINT MIL-H-83282			MINIMUM SHUTOFF PRESSURE (psid)	MIN. RECOMMENDED VALVE LIFT	
MAX. LOHM RATE	MIN. GPM	AT (psid)		MAX. LOHMS	MIN. GPM
300	0.7	100	68	1500	0.2
300	0.8	150	100	1500	0.2
300	1.1	250	170	1500	0.3
300	1.3	375	255	1500	0.3
300	1.6	500	340	1500	0.4
300	1.7	625	425	1500	0.4
300	1.9	750	510	1500	0.4
300	2.1	875	595	1500	0.5
300	2.2	1000	680	1500	0.5
300	2.4	1125	765	1500	0.5
300	2.5	1250	850	1500	0.5
300	2.6	1375	935	1500	0.6
300	2.7	1500	1020	1500	0.6
300	2.9	1750	1190	1500	0.6
300	3.2	2000	1360	1500	0.7
300	3.4	2250	1530	1500	0.7
300	3.5	2500	1700	1500	0.8
300	3.7	2750	1870	1500	0.8
300	3.9	3000	2040	1500	0.8
300	4.0	3125	2125	1500	0.8
300	4.0	3250	2210	1500	0.9
300	4.2	3500	2380	1500	0.9
300	4.3	3750	2550	1500	0.9
350	3.8	3875	2635	1500	0.9
350	3.8	4000	2720	1500	0.9
350	3.9	4125	2805	1500	1.0
350	4.0	4250	2890	1500	1.0
350	4.0	4375	2975	1500	1.0
350	4.1	4500	3060	1500	1.0

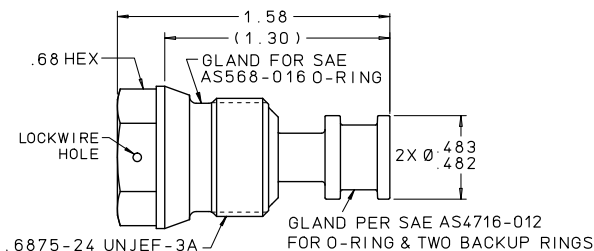

### MATERIALS

PART	MATERIAL	SPECIFICATION
Body	303 Cres	QQ-S-763C
Spring Seat	303 Cres	QQ-S-763C
Seat	303 Cres	QQ-S-763C
Retainer	303 Cres	QQ-S-763C
Ball Follower	303 Cres	QQ-S-763C
Spring	17-7PH Cres	AMS 5678
Tube	304 Cres	AMS 5639
Ball	440C Cres	AMS 5630
Screen*	304L Cres	ASTM A 666
Braze*	—	AMS 4774

\* For screened valves. *Finish: All Cres Parts Passivated.*

### PERFORMANCE

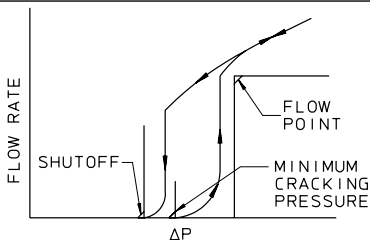

Leakage at Minimum Cracking Pressure ..... 1 mL/min (max.)

Leakage at Minimum Shutoff Pressure ..... 1 mL/min (max.)

Restriction at Minimum Recommended Valve Lift ..... 1500 Lohms

Nominal System Pressure ..... up to 3000 psi

System Proof Pressure ..... 4500 psi

Nominal Weight ..... 38 grams (unscreened) / 39 grams (screened)

Valve performance on MIL-PRF-83282 or MIL-PRF-5606 at 85° F +/- 15° F

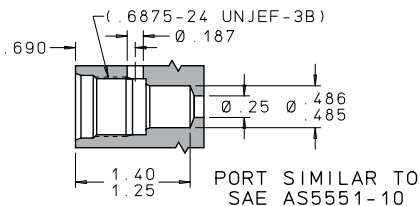

See Drawing for Complete Installation Hole Dimensions.

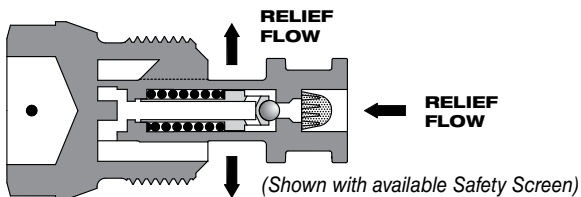

LEE PART NUMBER	MINIMUM CRACKING PRESSURE (psid)	FLOW POINT (MIL-PRF-83282)			MINIMUM SHUTOFF PRESSURE (psid)
		MAX. LOHM RATE	MIN. FLOW (GPM)	AT (psid)	
<b>687 Side Exit PRV</b>					
PRVA0687140 D	400	230	2.0	500	340
PRVA0687160 D	600	230	2.5	750	510
PRVA0687112 H	1200	230	3.6	1500	1020
PRVA0687116 H	1600	230	4.2	2000	1360
PRVA0687122 H	2200	230	5.0	2750	1870
PRVA0687126 H	2600	230	5.4	3250	2210
PRVA0687132 H	3200	280	4.8	4000	2720
PRVA0687136 H	3600	280	5.1	4500	3060
<b>Screened 687 Side Exit PRV</b>					
PRVA0687340 D	400	300	1.6	500	340
PRVA0687360 D	600	300	1.9	750	510
PRVA0687312 H	1200	300	2.7	1500	1020
PRVA0687316 H	1600	300	3.2	2000	1360
PRVA0687322 H	2200	300	3.7	2750	1870
PRVA0687326 H	2600	300	4.0	3250	2210
PRVA0687332 H	3200	350	3.8	4000	2720
PRVA0687336 H	3600	350	4.1	4500	3060

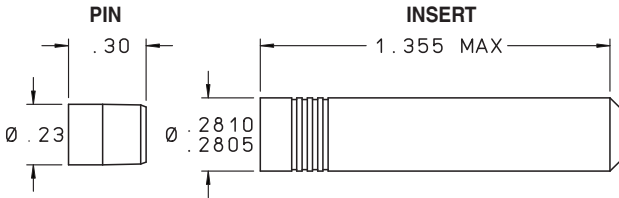

## MATERIALS

PART	MATERIAL	SPECIFICATION
Body	15-5PH Cres	AMS 5659
Pin	15-5PH Cres	AMS 5659
Seat	440C Cres	AMS 5630
Ball	Tungsten Carbide	—
Spring Seat	303 Cres	QQ-S-763C
Tube	17-4PH Cres	AMS 5643
Ball Follower	303 Cres	QQ-S-763C
Spring	17-7PH Cres	AMS 5678
Screen	304L Cres	ASTM A 666
Braze	—	AMS 4774

*Finish: All Cres Parts Passivated.*

*Pins are prewaxed. Do not degrease. Do not lubricate.*

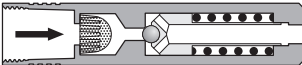

**PHFA2815320D**  
**RELIEF FLOW FORWARD**

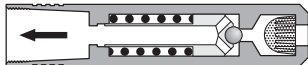

**PHRA2815320D**  
**RELIEF FLOW REVERSE**

LEE PART NUMBER		MINIMUM CRACKING PRESSURE (psid)	FLOW POINT			MINIMUM SHUTOFF PRESSURE (psid)
FORWARD	REVERSE		LOHM RATE	MIN. FLOW (gpm)	AT (psid)	
PHFA281*300D	PHRA281*300D	3000	1500	0.90	3600	2850
PHFA281*320D	PHRA281*320D	3200	1500	0.90	3850	3000
PHFA281*340D	PHRA281*340D	3400	1500	0.95	4050	3200
PHFA281*420D	PHRA281*420D	4200	1500	1.0	4750	3700
PHFA281*450D	PHRA281*450D	4500	1500	1.0	5100	4000
PHFA281*470D	PHRA281*470D	4700	1500	1.1	5300	4200
PHFA281*520D	PHRA281*520D	5200	1500	1.1	5800	4550
PHFA281*570D	PHRA281*570D	5700	1500	1.2	6350	5000
PHFA281*590D	PHRA281*590D	5900	1500	1.2	6600	5200

↑ \* Materials: 7 = NACE Compliant  
↑ \* Materials: 5 = Stainless Steel

## INSTALLATION HOLE

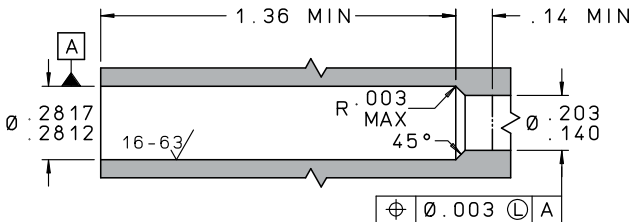

## INSTALLATION AND EXTRACTION

Tool Set Part Number ..... CUTA2810114C  
 Procedures ..... See **Pages N26 – N30**  
 Line Mount Configurations..... See **Pages L11 – L12**  
 Replacement Pin Part Number..... SHBA2810003A

*For boss size see **page N24**. For oversize see **page N28**.*

**F**

## PERFORMANCE

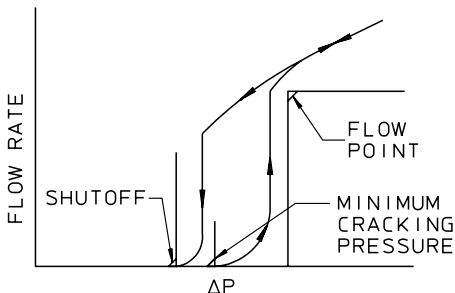

Leakage at Minimum Cracking Pressure ... 10 drops/minute (max.)  
 Leakage at Shutoff..... 10 drops/minute (max.)  
 Screen Hole Size..... 0.004" Nominal  
 Nominal System Pressure..... up to 5000 psi  
 System Peak Pressure..... 7500 psi (max.)  
 Nominal Weight ..... 6.0 grams

*Valve performance on MIL-PRF-83282 at 85°F. 1 drop = 50 μL*

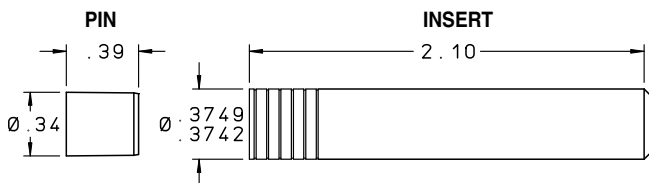

MATERIALS		
PART	MATERIAL	SPECIFICATION
Body	304 Cres	AMS 5639
Pin	17-4PH Cres	AMS 5643
Poppet	304 Cres	AMS 5639
Seat	440C Cres	AMS 5630
Spring	17-7PH Cres	AMS 5678
Ball	Tungsten Carbide	—
Retainer	15-5PH Cres	AMS 5659
Tube	13-8 MO Cres	AMS 5629
Orifice Plate	304 Cres	AMS 5639
Shim	17-7PH Cres	AMS 5529

Finish: All Cres Parts Passivated.

Pins are prewaxed. Do not degrease. Do not lubricate.

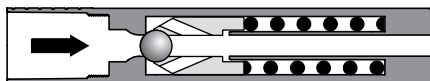

RELIEF FLOW FORWARD

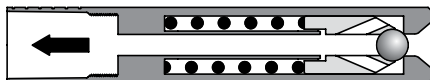

RELIEF FLOW REVERSE

LEE PART NUMBER		MINIMUM CRACKING PRESSURE (psid)	FLOW POINT			MINIMUM SHUTOFF PRESSURE (psid)
FORWARD	REVERSE		LOHM RATE	MIN. FLOW (gpm)	AT (psid)	
PHFA3751300D	PHRA3751300D	3000	400	3.7	3850	2850
PHFA3751320D	PHRA3751320D	3200	400	3.8	4050	3000
PHFA3751340D	PHRA3751340D	3400	400	3.9	4250	3200
PHFA3751420D	PHRA3751420D	4200	400	4.0	5250	4000
PHFA3751440D	PHRA3751440D	4400	400	4.1	5400	4200
PHFA3751520D	PHRA3751520D	5200	400	4.9	6550	5000
PHFA3751540D	PHRA3751540D	5400	400	5.0	6750	5200

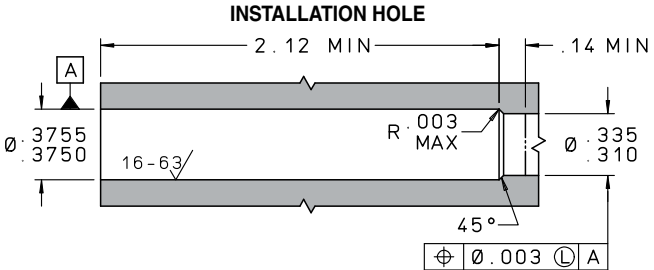

## INSTALLATION AND EXTRACTION

Tool Set Part Number ..... CUTA3750514C  
 Procedures ..... See **Pages N26 – N30**  
 Replacement Pin Part Number ..... PHRA3750003A  
*For boss size see **page N24**. For oversize see **page N28**.*

**F**

## PERFORMANCE

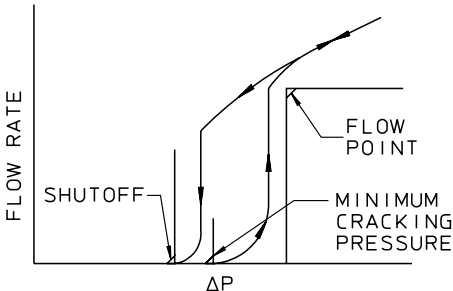

Leakage at Minimum Cracking Pressure: ..... 2 mL/min (max.)  
 Leakage at Minimum Shutoff Pressure: ..... 2 mL/min (max.)  
 Restriction at Minimum Recommended Valve Lift: ... 1500 Lohms  
 Nominal System Pressure: ..... up to 5000 psi  
 System Peak Pressure: ..... 6750 psi (max.)  
 Nominal Weight: ..... 20 grams

*Valve performance on MIL-PRF-83282 or MIL-PRF-5606 at 85°F ± 15°F*

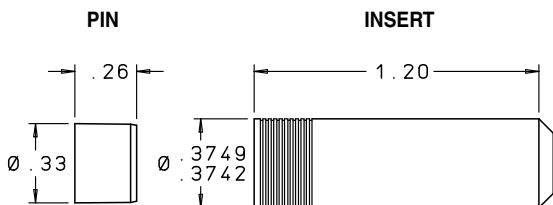

### MATERIALS

PART	MATERIAL	SPECIFICATION
Body	304 Cres	AMS 5639
Pin	17-4PH Cres	AMS 5643
Poppet	15-5PH Cres	AMS 5659
Spring Seat	304 Cres	AMS 5639
Spring	17-7PH Cres	AMS 5678
Seat	440C Cres	AMS 5630

*Finish: All Cres Parts Passivated.*

*Pins are prewaxed. Do not degrease. Do not lubricate.*

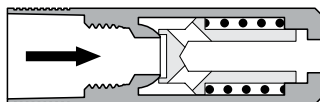

**PRFA3756050L • RELIEF FLOW FORWARD**

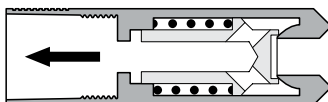

**PRRA3756050L • RELIEF FLOW REVERSE**

LEE PART NUMBER		MINIMUM CRACKING PRESSURE (psid)	FLOW POINT			MINIMUM SHUTOFF PRESSURE (psid)
FORWARD	REVERSE		LOHM RATE	MIN. FLOW (gpm)	AT (psid)	
PRFA3756050L	PRRA3756050L	50	100	1.7	63	45
PRFA3756080L	PRRA3756080L	80	100	2.1	100	72
PRFA3756120L	PRRA3756120L	120	100	2.6	150	108
PRFA3756200L	PRRA3756200L	200	100	3.4	250	180
PRFA3756300L	PRRA3756300L	300	100	4.2	375	270
PRFA3756400L	PRRA3756400L	400	100	4.8	500	360
PRFA3756500L	PRRA3756500L	500	100	5.4	625	450

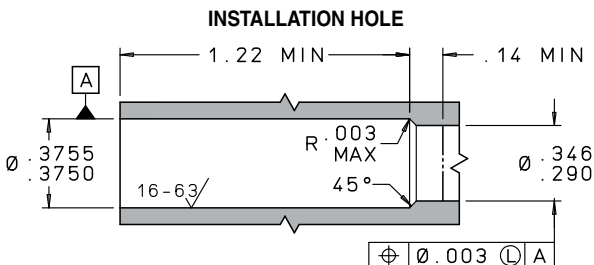

## INSTALLATION AND EXTRACTION

Tool Set Part Numbers: Forward..... CUTA3750106C  
 Reverse..... CUTA3750214C  
 Procedures ..... See **Pages N26 – N30**  
 Replacement Pin Part Number..... CKFA3750003A  
*For boss size see **page N24**. For oversize see **page N28**.*

**F**

## PERFORMANCE

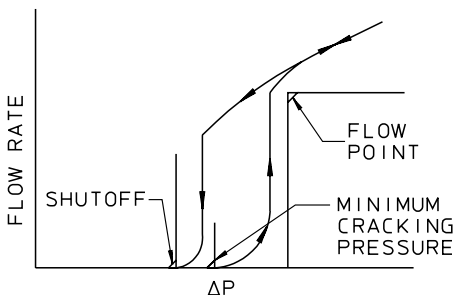

Leakage at Minimum Cracking Pressure ... 5 drops/minute (max.)  
 Leakage at Shutoff..... 20 drops/minute (max.)  
 Restriction at Minimum  
     Recommended Valve Lift..... 500 Lohms (max.)  
 Nominal System Pressure..... up to 3000 psi  
 Nominal Weight ..... 10.0 grams  
*Valve performance on MIL-PRF-83282 at 85°F. 1 drop = 50  $\mu$ L*

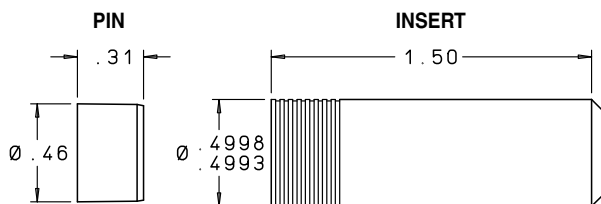

### MATERIALS

PART	MATERIAL	SPECIFICATION
Body	304 Cres	AMS 5639
Pin	15-5PH Cres	AMS 5659
Poppet	15-5PH Cres	AMS 5659
Spring Seat	303 Cres	QQ-S-763C
Spring	17-7PH Cres	AMS 5678
Seat	440C Cres	AMS 5630

*Finish: All Cres Parts Passivated.*

*Pins are prewaxed. Do not degrease. Do not lubricate.*

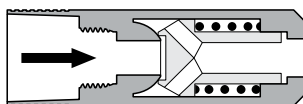

**PRFA5006050L • RELIEF FLOW FORWARD**

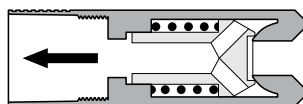

**PRRA5006050L • RELIEF FLOW REVERSE**

LEE PART NUMBER		MINIMUM CRACKING PRESSURE (psid)	FLOW POINT			MINIMUM SHUTOFF PRESSURE (psid)
FORWARD	REVERSE		LOHM RATE	MIN. FLOW (gpm)	AT (psid)	
PRFA5006050L	PRRA5006050L	50	50	3.4	63	45
PRFA5006080L	PRRA5006080L	80	50	4.2	100	72
PRFA5006120L	PRRA5006120L	120	50	5.2	150	108
PRFA5006200L	PRRA5006200L	200	50	6.8	250	180
PRFA5006300L	PRRA5006300L	300	50	8.4	375	270
PRFA5006400L	PRRA5006400L	400	50	9.6	500	360
PRFA5006500L	PRRA5006500L	500	50	10.8	625	450

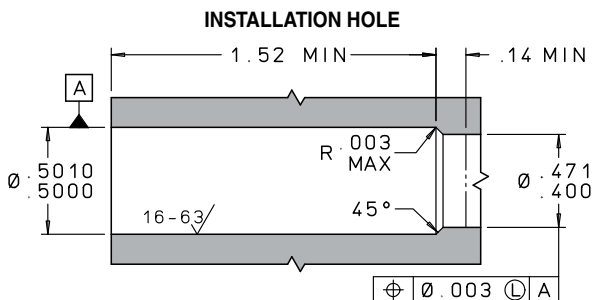

## INSTALLATION AND EXTRACTION

Tool Set Part Numbers: Forward ..... CUTA5000106C  
 Reverse ..... CUTA5000116C  
 Procedures ..... See [Pages N26 – N30](#)  
 Replacement Pin Part Number ..... CKFA5000003A  
 For boss size see [page N24](#). For oversize see [page N28](#).

F

## PERFORMANCE

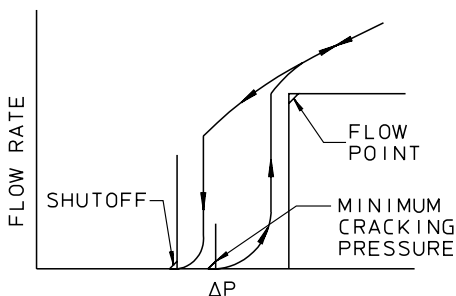

Leakage at Minimum Cracking Pressure ... 10 drops/minute (max.)  
 Leakage at Shutoff ..... 20 drops/minute (max.)  
 Restriction at Minimum  
     Recommended Valve Lift ..... 350 Lohms (max.)  
 Nominal System Pressure ..... up to 3000 psi  
 Nominal Weight ..... 20.0 grams

*Valve performance on MIL-PRF-83282 at 85°F. 1 drop = 50  $\mu$ L*

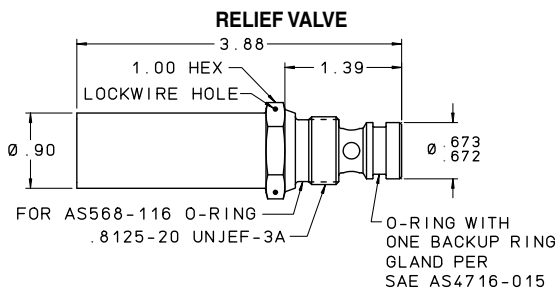

### MATERIALS

PART	MATERIAL	SPECIFICATION
Body	304 Cres	AMS 5639
Poppet Retainer	304 Cres	AMS 5639
Spring Seat	304 Cres	AMS 5639
Spring Seat Vent	316L Cres	(Sintered)
Spring Guide	304 Cres	AMS 5639
Seat	15-5PH Cres	AMS 5659
Piston	Nitronic 60	AMS 5848
Springs	17-7PH Cres	AMS 5678
Poppet	Polyimide	—
Piston Seals	Viton	AMS-R-83485
	PTFE	AS 8791

*Finish: All Cres Parts Passivated.*

LEE PART NUMBER	MIN. CRACKING PRESSURE (psid)	FLOW POINT			MIN. SHUTOFF PRESSURE (psid)
		LOHM RATE	MIN. FLOW (gpm)	AT (psid)	
PRVA0812010H	1000	75	11.3	1500	850
PRVA0812012H	1200	75	11.8	1650	1000
PRVA0812014H	1400	75	12.7	1900	1200
PRVA0812022H	2200	75	15.1	2750	2000
PRVA0812024H	2400	75	15.9	3000	2200
PRVA0812032H	3200	75	18.5	4050	3000
PRVA0812034H	3400	75	19.0	4250	3200
PRVA0812042H	4200	100	15.8	5250	4000
PRVA0812044H	4400	100	16.2	5500	4200
PRVA0812052H	5200	100	17.6	6500	5000
PRVA0812054H	5400	100	17.9	6750	5200

## INSTALLATION HOLE

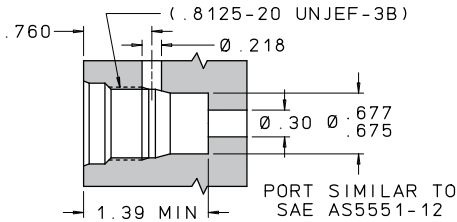

See Drawing for Complete Installation Hole Dimensions.

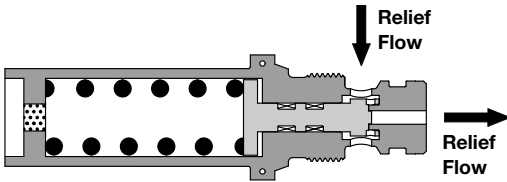

F

## PERFORMANCE

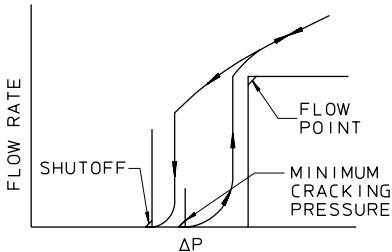

Leakage at Minimum Cracking Pressure: ..... 1 mL/min (max.)

Leakage at Minimum Shutoff Pressure: ..... 1 mL/min (max.)

External Leakage: ..... 0 mL

Restriction at Minimum Recommended Valve Lift: ..... 600 Lohms

Nominal System Pressure: ..... up to 5000 psi

System Peak Pressure: ..... 6750 psi (max.)

Non-Relief Direction Differential Pressure: ..... 500 psid (max.)

Nominal Weight: ..... 200 grams

Valve performance on MIL-PRF-83282 or MIL-PRF-5606 at 85°F ± 15°F

## PIN

## INSERT

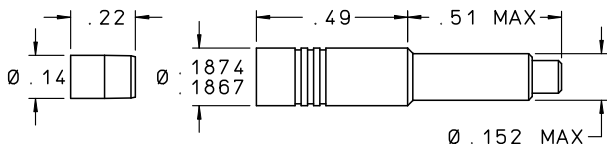

## MATERIALS

PART	MATERIAL	SPECIFICATION
Body	304 Cres	AMS 5639
Pin	17-4PH Cres	AMS 5643
Spring Seat	304 Cres	AMS 5639
Spring	17-7PH Cres	AMS 5678
Ball Follower	17-4PH Cres	AMS 5643
Ball	Ceramic	—
Seat	Ceramic	—
Orifice	17-4PH Cres	AMS 5643
Filter	316 Cres	15 $\mu$ m Nominal

Finish: All Cres Parts Passivated.

Pins are prewaxed. Do not degrease. Do not lubricate.

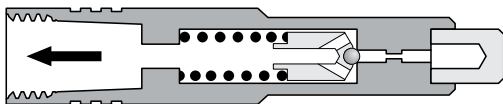

PRTA1871350D • RELIEF FLOW REVERSE

LEE PART NUMBER	MINIMUM CRACKING PRESSURE (psid)	FLOW POINT			MINIMUM SHUTOFF PRESSURE (psid)
		LOHM RATE	MIN. ml/min.	AT (psid)	
PRTA1871350D	3500	325 000	15	4050	3200
PRTA1871470D	4700	325 000	17	5300	4200

## INSTALLATION HOLE

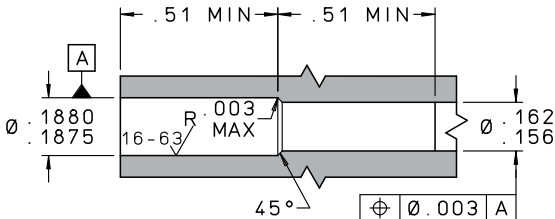

## INSTALLATION AND EXTRACTION

Tool Set Part Number .....	CUTA1870104C
Procedures .....	See <b>Pages N26 – N30</b>
Line Mount Configurations.....	See <b>Pages L6 – L8</b>
Replacement Pin Part Number.....	JEVA1870003B

For boss size see **page N24**. For oversize see **page N28**.

## PERFORMANCE

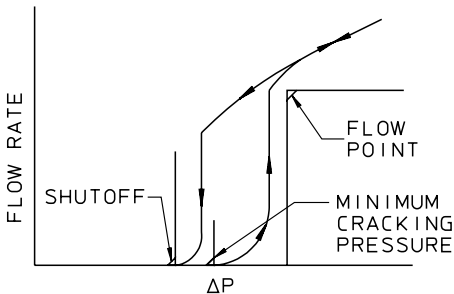

Leakage at Minimum Cracking Pressure ....	4 drops/minute (max.)
Leakage at Shutoff.....	40 drops/hour (max.) after a 2 minute wait
Integral Filtration .....	15 $\mu$ m Nominal
Nominal System Pressure.....	up to 4000 psi
System Peak Pressure.....	5400 psi (max.)
Nominal Weight .....	2.6 grams

Valve performance on MIL-PRF-83282 at 85°F. 1 drop = 50  $\mu$ L

PIN

INSERT

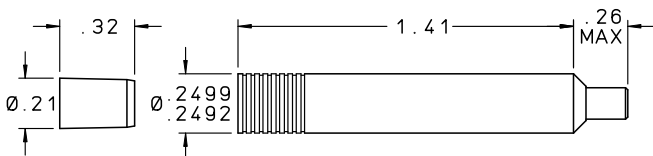

### MATERIALS

PART	MATERIAL	SPECIFICATION
Body	304 Cres	AMS 5639
Pin	17-4PH Cres	AMS 5678
Seat	440C Cres	AMS 5630
Ball	Tungsten Carbide	—
Spring Seat	303 Cres	QQ-S-763C
Tube	304 Cres	AMS 5639
Ball Follower	303 Cres	QQ-S-763C
Spring	17-7PH Cres	AMS 5678
Filter	316 Cres	—

*Finish: All Cres Parts Passivated.*

*Pins are prewaxed. Do not degrease. Do not lubricate.*

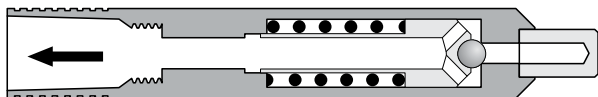

PHTA2501470D • RELIEF FLOW REVERSE

LEE PART NUMBER	MINIMUM CRACKING PRESSURE (psid)	FLOW POINT			MINIMUM SHUTOFF PRESSURE (psid)
		LOHM RATE	MIN. ml/min.	AT (psid)	
PHTA2501350D	3500	105 000	50	4050	3200
PHTA2501470D	4700	122 000	50	5300	4200
PHTA2501580D	5800	136 000	50	6650	5200

## INSTALLATION HOLE

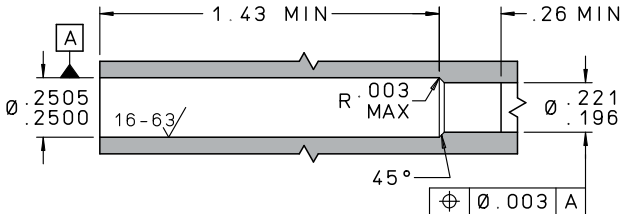

## INSTALLATION AND EXTRACTION

Tool Set Part Number ..... CUTA2500406C  
 Procedures ..... See **Pages N26 – N30**  
 Line Mount Configurations..... See **Pages L11 – L12**  
 Replacement Pin Part Number..... CHFA2500003A

*For boss size see **page N24**. For oversize see **page N28**.*

**F**

## PERFORMANCE

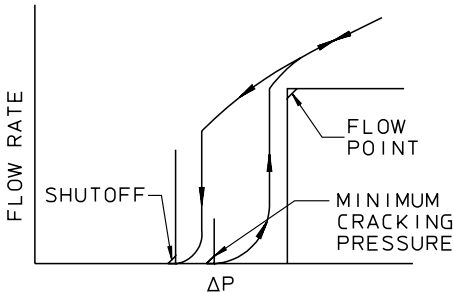

Leakage at Minimum Cracking Pressure ... 3 drops/minute (max.)  
 Leakage at Shutoff..... 3 drops/minute (max.)  
 after a 2 minute wait  
 Integral Filtration .....  $10\mu\text{m}$  Nominal  
 Nominal System Pressure..... up to 5000 psi  
 System Peak Pressure..... 7500 psi (max.)  
 Nominal Weight ..... 4.5 grams

*Valve performance on MIL-PRF-83282 at 85°F. 1 drop = 50  $\mu\text{L}$*

PIN

INSERT

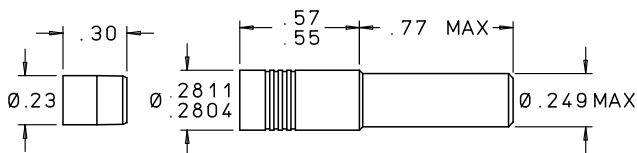

### MATERIALS

PART	MATERIAL	SPECIFICATION
Body	15-5PH Cres	AMS 5659
Pin	15-5PH Cres	AMS 5659
Poppet	440C Cres	AMS 5630
Seal	Polymer	—
Poppet Guide	303 Cres	QQ-S-763C
Retainers	303 Cres	QQ-S-763C
Spring Guide	303 Cres	QQ-S-763C
Spring Seat	303 Cres	QQ-S-763C
Spring	17-7PH Cres	AMS 5678
Screen	304L Cres	ASTM A 666
Braze	—	AMS 4774

*Finish: All Cres Parts Passivated.*

*Pins are prewaxed. Do not degrease. Do not lubricate.*

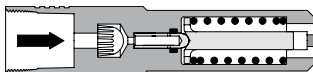

RELIEF FLOW FORWARD

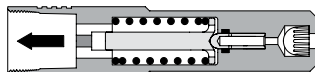

RELIEF FLOW REVERSE

LEE PART NUMBER		MIN. CRACKING PRESSURE (psid)	FLOW POINT			MIN. SHUT-OFF PRESSURE (psid)
FORWARD	REVERSE		LOHM RATE	MIN. FLOW (ml/min.)	AT (psid)	
PSFA2813800L	PSRA2813800L	800	100 000	25	930	660
PSFA2813130D	PSRA2813130D	1300	100 000	33	1500	1100
PSFA2813250D	PSRA2813250D	2500	100 000	45	3000	2100
PSFA2813350D	PSRA2813350D	3500	100 000	55	4050	3100
PSFA2813470D	PSRA2813470D	4700	100 000	63	5400	4100

## INSTALLATION HOLE

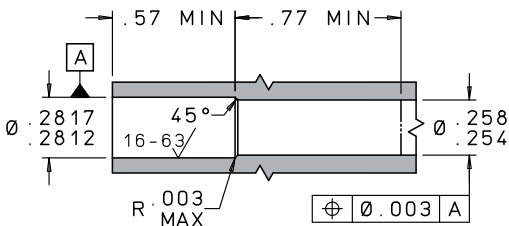

## INSTALLATION AND EXTRACTION

Tool Set Part Numbers:..... CUTA2810114C  
 Procedures ..... See **Pages N26 – N30**  
 Replacement Pin Part Number..... SHBA2810003A

*For boss size see **page N24**. For oversize see **page N28**.*



## PERFORMANCE

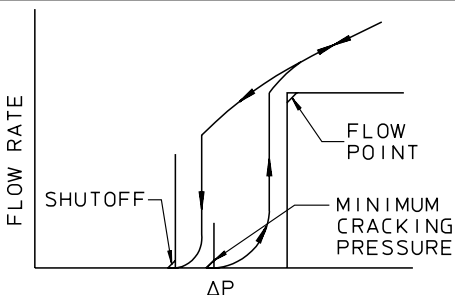

- Leakage at Minimum Cracking Pressure: ... Zero drops in a one minute test;  
1 drop/hour (max.)
- Leakage at Minimum Shutoff Pressure: .... Zero drops in a one minute test;  
1 drop/hour (max.)
- Nominal System Pressure: ..... 4000 psi (max.)
- System Peak Pressure:..... 5400 psi (max.)
- Screen Hole Size: ..... .004" nominal

*Valve performance on MIL-PRF-83282 or MIL-PRF-5606 at 85°F ± 15°*

# Lee Shuttle Valves

G





- ❑ **Miniature Insert Fits in the Head of an Actuator**
- ❑ **Eliminates Common Mode Failures**
- ❑ **Non-interflow Design**
- ❑ **No Elastomeric Seals Required**
- ❑ **Low Leakage or Zero Leakage**

## TABLE OF CONTENTS

<b>Spring Biased Shuttle Valves</b>	0.187", 0.281" & 0.500" Diameter Spring Biased Shuttle Valves for 4000 psi systems.....	6 – 13
<b>High Pressure Spring Biased Shuttle Valves</b>	0.187", 0.281", 0.375" & 0.500" Diameter Spring Biased Shuttle Valves for 5000 psi systems.....	14 – 21
<b>Detented Shuttle Valves</b>	0.281", 0.375" & 0.500" Diameter Detented Shuttle Valves in All-Metal or Zero Leak Versions .....	22 – 33
<b>Selective Shuttle Valves</b>	0.187", 0.250", 0.375" & 0.500" Diameter Non-Biased Shuttle Valves .....	34 – 41
<b>Inverse Shuttle Valves</b>	0.250" & 0.500" Diameter Inverse Shuttle Valves for up to 5000 psi systems ...	42 – 45

The Lee Shuttle Valve is offered in four configurations. One type is the spring biased shuttle valve with the emergency port normally closed. Another type is the detented shuttle valve where the poppet latches to close off either the emergency port or the normal port. Also there are selective shuttle valves with a non-biased, loose ball design. Finally there are inverse shuttle valves where the lower pressure inlet port is open to the common port instead of the higher pressure inlet port.

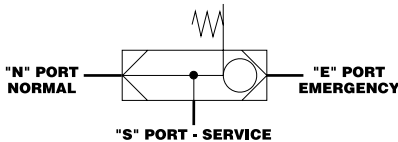

Lee Shuttle Valves are designed to isolate the normal from the emergency hydraulic system during normal operation. When pressure is lost in the normal system and emergency pressure is applied, the poppet shuttles across to block the normal port allowing flow to the cylinder. Lee Spring Biased and Detented Shuttle Valves are of the “non-interflow” type, which means the normal port closes before the emergency port opens. At no time are all 3 ports open simultaneously. The interflow leak is limited to less than 3 mL per cycle permitted by MIL-V-19068. The requirement for this valve is commonly found in aircraft landing gear hydraulic systems shown in a typical circuit on the opposite page.

## LANDING GEAR (Shown Retracted)

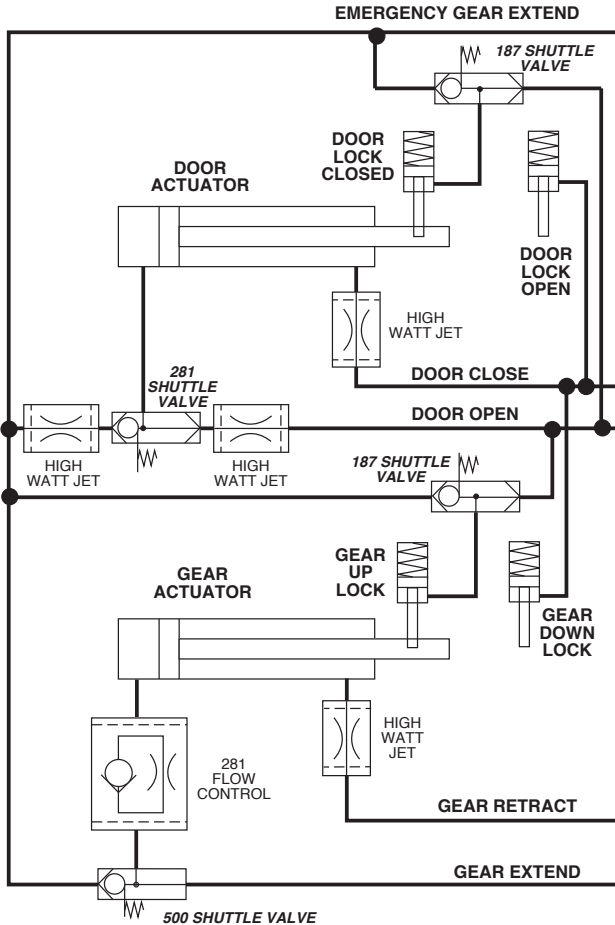

Lee Spring Biased Shuttle Valves can be used to reduce the flow required to extend a large unequal area actuator, where reduced actuation force may be permissible in one direction. When the retract line is pressurized the valve shuttles across to isolate the retract line from the extend line. When the extend line is pressurized the valve blocks the retract line allowing flow from the smaller area retract side of the piston to flow to the extend side. Only a small “make-up” flow is required from the main hydraulic system.

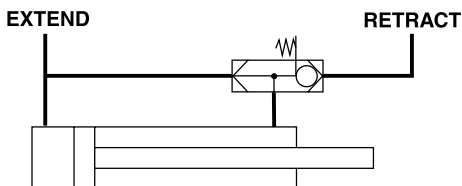

Lee Detented Shuttle Valves are intended for use in systems where bidirectional flow is required between the “S” and “E” ports, such as in most brake circuits. These applications require a detented/latching poppet design. A zero leak version of the detented shuttle is also available. This design is essential for systems using a gas emergency system to back up the primary hydraulic system.

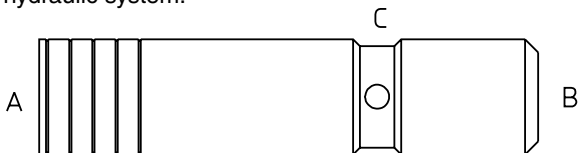

The Lee Inverse Shuttle Valve operates in a manner opposite to that of a Spring Biased Shuttle Valve. Rather than sensing and allowing the higher pressure side to flow, it selects the lower pressure and allows it to flow instead. For example, if the pressure at port **A** is greater than the pressure at port **B**, port **A** closes and forces

open port **B**, allowing flow between **B** and **C**. The opposite is true if the pressure at port **B** is greater than at **A**. It is also possible to flow out port **A** and **B** simultaneously when **C** is the inlet. This valve can be used in a variety of different applications such as sensing the lower pressure of two different lines or providing an anti-cavitation and anti-pressure intensification function when used in hydrostatic actuation systems.

Lee Shuttle Valves are miniature inserts that are so small they fit right in the head of an actuator, saving space and weight, as well as protecting them from external physical damage. With direct communication from the “S” port into the actuator, without external plumbing, common mode failures are virtually eliminated.

As with all Lee inserts, they require no O-rings or elastomeric seals. Since the shuttle valve is a three port insert, an additional seal beyond the normal locking end is required. The “nose seal” works in the same manner as a locking end except a tapered section of the insert body acts as the tapered pin. The nose seal rests on a 45° shoulder and is expanded as the body is pressed down into the installation hole.

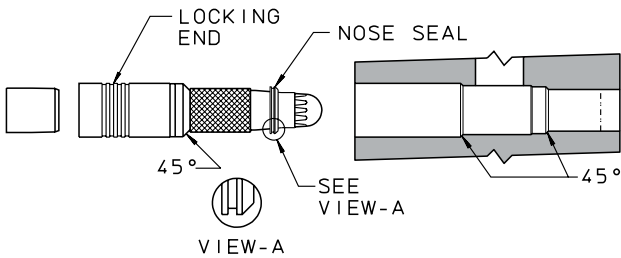

Some sizes of the spring biased shuttle valves are available with filter screens which prevent large contaminants generated in the actuator from getting into the valve or the hydraulic system.



PIN

INSERT

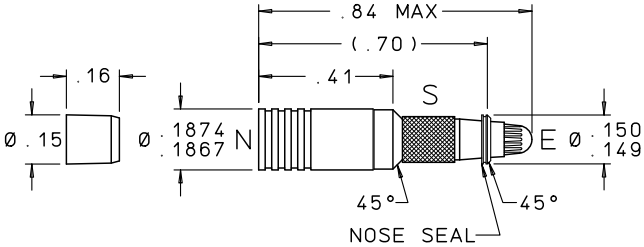

### MATERIALS

PART	MATERIAL	SPECIFICATION
Body – Rear	304L Cres	AMS 5647
Body – Front	15-5PH Cres	AMS 5659
Pin	17-4PH Cres	AMS 5643
Spring	17-7PH Cres	AMS 5678
Poppet	440C Cres	AMS 5630
Nose Seal	6061-T6 Al	AMS 4117
Barrel Screen	15-5PH Cres	AMS 5659
Screens	304L Cres	QQ-S-766
Base Washers	304L Cres	QQ-S-766
Braze	—	AMS 4774

*Finish: All Cres Parts Passivated.*

*All Aluminum Parts Alodined.*

*Pins are prewaxed. Do not degrease. Do not lubricate.*

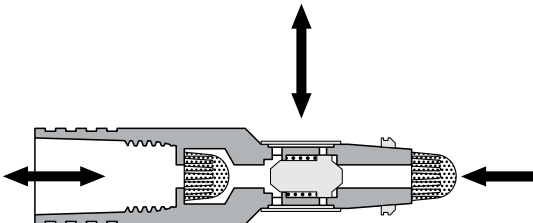

SVBA1870170D

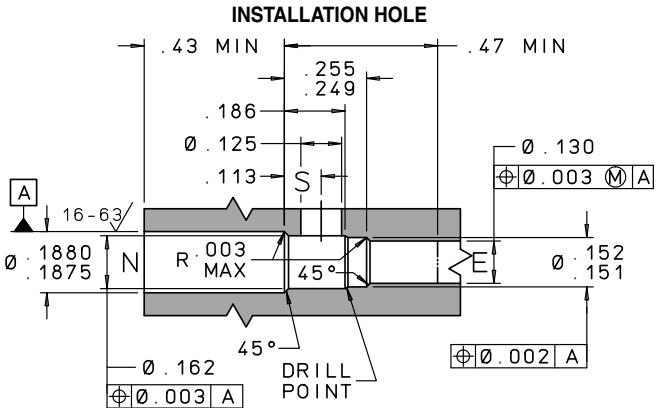

## INSTALLATION AND EXTRACTION

Tool Set Part Number ..... CUTA1870137C  
 Procedures ..... See **Pages N31 – N32**  
 Replacement Pin Part Number ..... CKFA1870005A  
 Replacement Nose Seal Part Number .... SVBA1870009B

*For boss size see **page N24**. For oversize see **page N28**.*

## PERFORMANCE

Flow Rate:  
 Normal (N to S or S to N) ..... 700 Lohms Max. Restriction  
 (.22 GPM min. at 50 psid)  
 Emergency (E to S) ..... 700 Lohms Max. Restriction  
 (.22 GPM min. at 50 psid)  
 Maximum Rated Flow ..... 1.3 GPM  
 Shuttling Pressure ..... 15 psid (Minimum) 40 psid (Maximum)  
 Leakage: (N to E or E to N) ..... 5 Drops/Hour (Maximum)  
 at 4000 psid after 2 Minute wait  
 Screen Hole Size ..... 0.008" Nom.  
 Nominal System Pressure ..... up to 4000 psi  
 Nominal Weight ..... 1.5 grams  
*Valve performance on MIL-PRF-83282 at 85°F. 1 drop = 50 µL*

PIN

INSERT

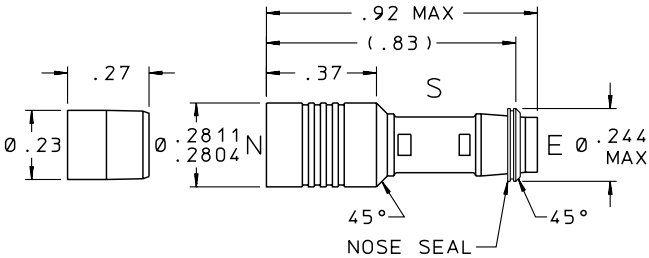

## MATERIALS

PART	MATERIAL	SPECIFICATION
Body – Rear	304L Cres	AMS 5647
Body – Front	15-5PH Cres	AMS 5659
Pin	303 Cres	QQ-S-763C
Spring	17-7PH Cres	AMS 5678
Poppet	440C Cres	AMS 5630
Nose Seal	6061-T6 Al	AMS 4117

*Finish: All Cres Parts Passivated.*

*All Aluminum Parts Alodined.*

*Pins are prewaxed. Do not degrease. Do not lubricate.*

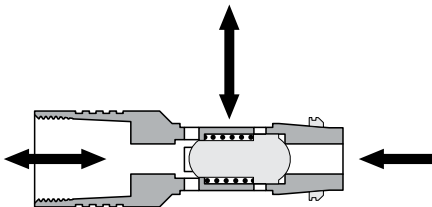

SVBA2810313D

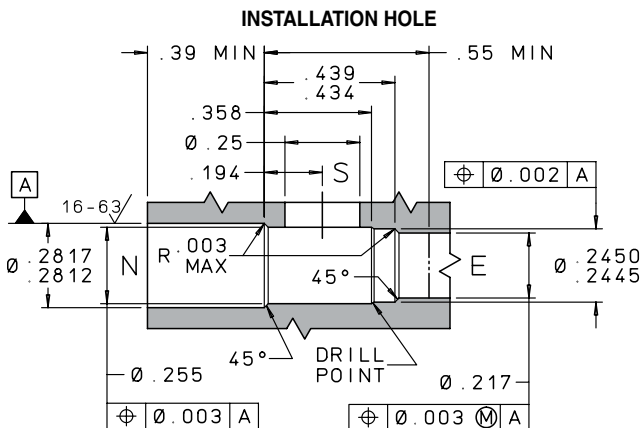

## INSTALLATION AND EXTRACTION

Tool Set Part Number ..... CUTA2810137C  
 Procedures ..... See **Pages N31 – N32**  
 Replacement Pin Part Number..... PRFA2810003A  
 Replacement Nose Seal Part Number .... SVBA2810009B

*For boss size see **page N24**. For oversize see **page N28**.*

## PERFORMANCE

### Flow Rate:

Normal (N to S or S to N) ..... 130 Lohms Max. Restriction  
 (1.2 GPM min. at 50 psid)

Emergency (E to S) ..... 130 Lohms Max. Restriction  
 (1.2 GPM min. at 50 psid)

Maximum Rated Flow ..... 7.2 GPM

Shuttling Pressure..... 15 psid (Minimum) 40 psid (Maximum)

Leakage: (N to E or E to N) ..... 5 Drops/Hour (Maximum)  
 at 4000 psid after 2 Minute wait

Nominal System Pressure ..... up to 4000 psi

Nominal Weight ..... 4.0 grams

*Valve performance on MIL-PRF-83282 at 85°F. 1 drop = 50  $\mu$ L*

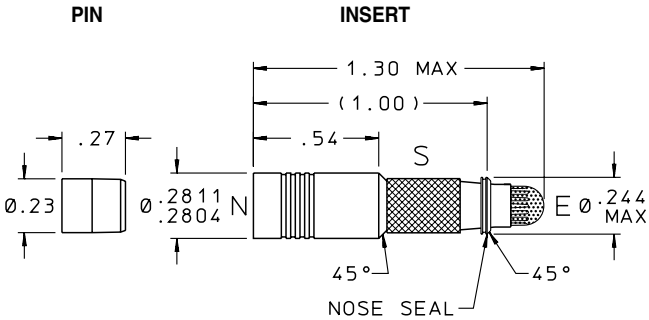

### MATERIALS

PART	MATERIAL	SPECIFICATION
Body – Rear	304L Cres	AMS 5647
Body – Front	15-5PH Cres	AMS 5659
Pin	303 Cres	QQ-S-763C
Spring	17-7PH Cres	AMS 5678
Poppet	440C Cres	AMS 5630
Nose Seal	6061-T6 Al	AMS 4117
Barrel Screen	15-5PH Cres	AMS 5659
Screens	304L Cres	QQ-S-766
Base Washers	304L Cres	QQ-S-766
Braze	—	AMS 4774

*Finish: All Cres Parts Passivated.*

*All Aluminum Parts Alodined.*

*Pins are prewaxed. Do not degrease. Do not lubricate.*

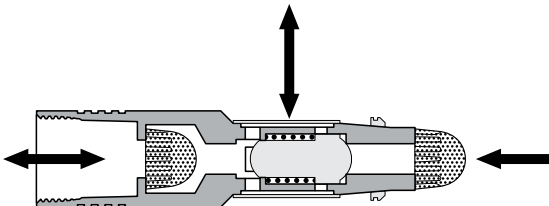

SVBA2810118D

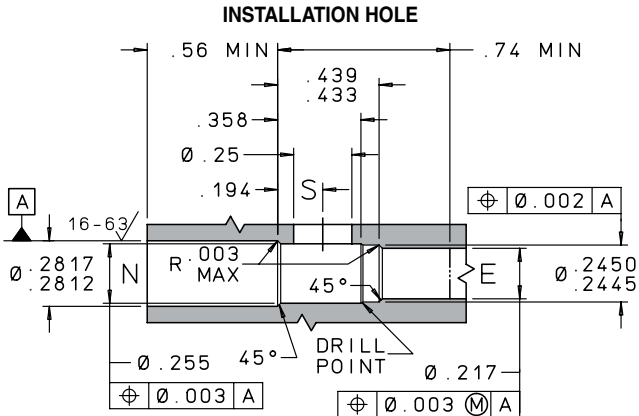

## INSTALLATION AND EXTRACTION

Tool Set Part Number ..... CUTA2810137C  
 Procedures ..... See **Pages N31 – N32**  
 Replacement Pin Part Number..... PRFA2810003A  
 Replacement Nose Seal Part Number .... SVBA2810009B

*For boss size see **page N24**. For oversize see **page N28**.*

## PERFORMANCE

### Flow Rate:

Normal (N to S or S to N) ..... 180 Lohms Max. Restriction  
 (0.85 GPM min. at 50 psid)  
 Emergency (E to S) ..... 180 Lohms Max. Restriction  
 (0.85 GPM min. at 50 psid)

Maximum Rated Flow ..... 6.0 GPM

Shuttling Pressure..... 15 psid (Minimum) 40 psid (Maximum)

Leakage: (N to E or E to N) ..... 5 Drops/Hour (Maximum)  
 at 4000 psid after 2 Minute wait

Screen Hole Size ..... 0.008"

Nominal System Pressure ..... up to 4000 psi

Nominal Weight ..... 5.0 grams

*Valve performance on MIL-PRF-83282 at 85°F. 1 drop = 50 µL*

## PIN

## INSERT

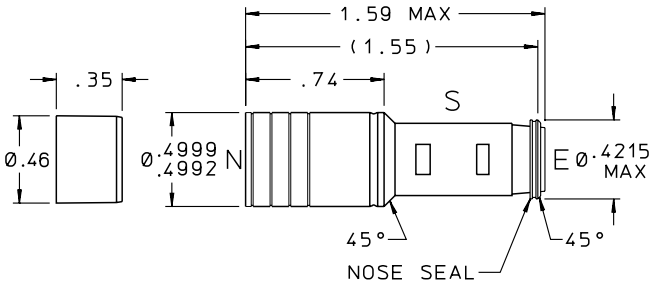

## MATERIALS

PART	MATERIAL	SPECIFICATION
Body – Rear	15-5PH Cres	AMS 5659
Body – Front	15-5PH Cres	AMS 5659
Pin	15-5PH Cres	AMS 5659
Spring	17-7PH Cres	AMS 5678
Poppet	440C Cres	AMS 5630
Nose Seal	6061-T6 Al	AMS 4117

Finish: All Cres Parts Passivated.

All Aluminum Parts Alodined.

Pins are prewaxed. Do not degrease. Do not lubricate.

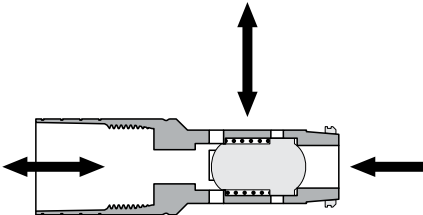

SVBA5000335L

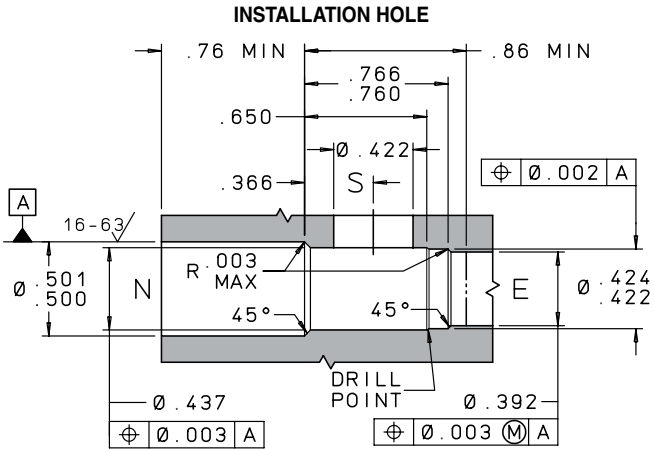

## INSTALLATION AND EXTRACTION

Tool Set Part Number ..... CUTA5000137C  
 Procedures ..... See [Pages N31 – N32](#)  
 Replacement Pin Part Number..... SVBA5000003A  
 Replacement Nose Seal Part Number .... SVBA5000009B

*For boss size see [page N24](#). For oversize see [page N28](#).*

## PERFORMANCE

### Flow Rate:

Normal (N to S or S to N) ..... 35 Lohms Max. Restriction  
 (4.4 GPM min. at 50 psid)  
 Emergency (E to S) ..... 35 Lohms Max. Restriction  
 (4.4 GPM min. at 50 psid)

Maximum Rated Flow ..... 20.4 GPM

Shuttling Pressure..... 15 psid (Minimum) 40 psid (Maximum)

Leakage: (N to E or E to N)..... 5 Drops/Hour (Maximum)  
 at 4000 psid) after 2 Minute wait

Nominal System Pressure ..... up to 4000 psi

Nominal Weight ..... 17 grams

*Valve performance on MIL-PRF-83282 at 85°F. 1 drop = 50 µL*

PIN

INSERT

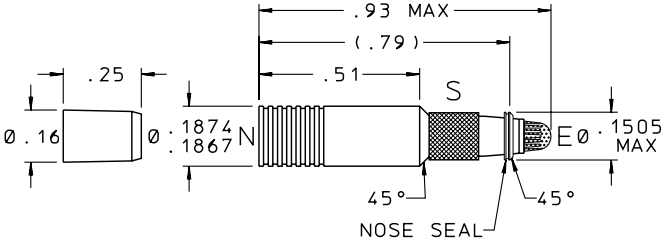

**MATERIALS**

PART	MATERIAL	SPECIFICATION
Body – Rear	304L Cres	AMS 5647
Body – Front	15-5PH Cres	AMS 5659
Pin	17-4PH Cres	AMS 5643
Spring	17-7PH Cres	AMS 5678
Poppet	440C Cres	AMS 5630
Nose Seal	6061-T6 Al	AMS 4117
Barrel Screen	15-5PH Cres	AMS 5659
Screens	304L Cres	QQ-S-766
Base Washers	304L Cres	QQ-S-766
Braze	—	AMS 4774

*Finish: All Cres Parts Passivated.*

*All Aluminum Parts Alodined.*

*Pins are prewaxed. Do not degrease. Do not lubricate.*

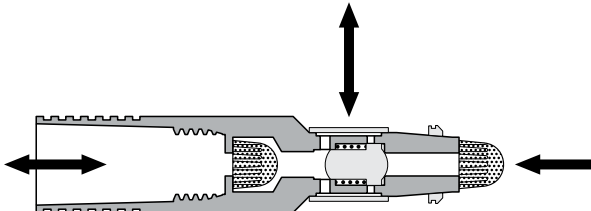

SHBA1870170D

## INSTALLATION HOLE

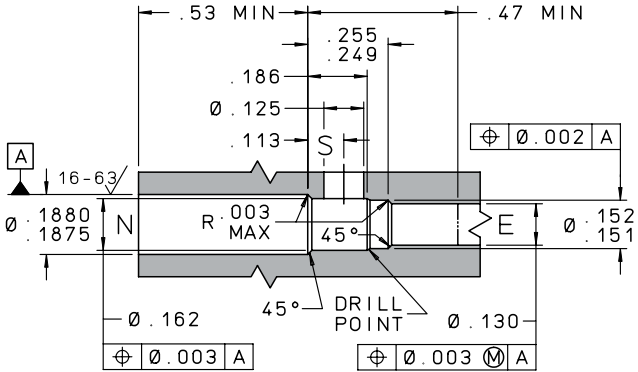

## INSTALLATION AND EXTRACTION

Tool Set Part Number ..... CUTA1870137C  
 Procedures ..... See **Pages N31 – N32**  
 Replacement Pin Part Number ..... JHHA1870003A  
 Replacement Nose Seal Part Number .... SVBA1870009B

*For boss size see **page N24**. For oversize see **page N28**.*

## PERFORMANCE

### Flow Rate:

Normal (N to S or S to N) ..... 700 Lohms Max. Restriction  
 (.22 GPM min. at 50 psid)

Emergency (E to S) ..... 700 Lohms Max. Restriction  
 (.22 GPM min. at 50 psid)

Maximum Rated Flow ..... 1.3 GPM

Shuttling Pressure ..... 15 psid (Minimum) 40 psid (Maximum)

Leakage: (N to E or E to N) ..... 5 Drops/Hour (Maximum)  
 at 5000 psid after 2 Minute wait

Screen Hole Size ..... 0.008" Nom.

Nominal System Pressure ..... up to 5000 psi

Nominal Weight ..... 1.5 grams

*Valve performance on MIL-PRF-83282 at 85°F. 1 drop = 50 µL*



PIN

INSERT

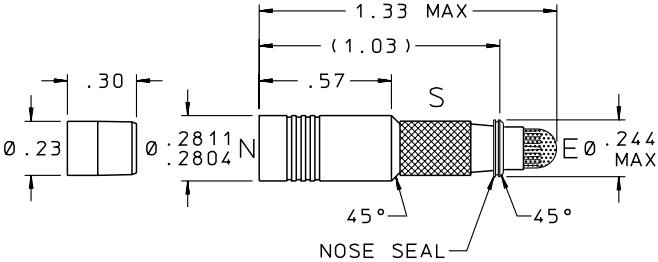

## MATERIALS

PART	MATERIAL	SPECIFICATION
Body – Rear	304L Cres	AMS 5647
Body – Front	15-5PH Cres	AMS 5659
Pin	15-5PH Cres	AMS 5659
Spring	17-7PH Cres	AMS 5678
Poppet	440C Cres	AMS 5630
Nose Seal	6061-T6 Al	AMS 4117
Barrel Screen	15-5PH Cres	AMS 5659
Screens	304L Cres	QQ-S-766
Base Washers	304L Cres	QQ-S-766
Braze	—	AMS 4774

*Finish: All Cres Parts Passivated.*

*All Aluminum Parts Alodined.*

*Pins are prewaxed. Do not degrease. Do not lubricate.*

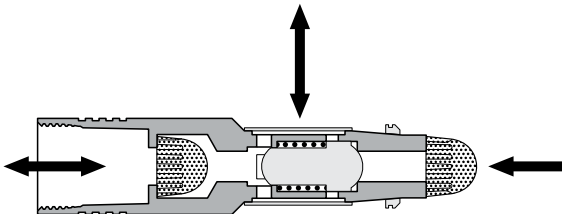

SHBA2810118D

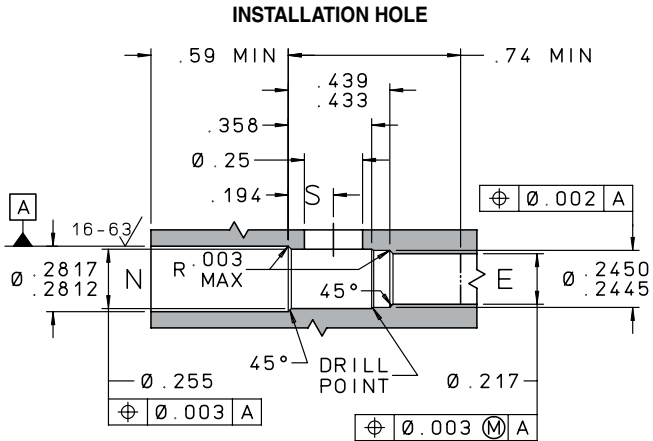

## INSTALLATION AND EXTRACTION

Tool Set Part Number ..... CUTA2810137C  
 Procedures ..... See **Pages N31 – N32**  
 Replacement Pin Part Number ..... SHBA2810003A  
 Replacement Nose Seal Part Number .... SVBA2810009B

*For boss size see **page N24**. For oversize see **page N28**.*

## PERFORMANCE

### Flow Rate:

Normal (N to S or S to N) ..... 180 Lohms Max. Restriction  
 (.85 GPM min. at 50 psid)

Emergency (E to S) ..... 180 Lohms Max. Restriction  
 (.85 GPM min. at 50 psid)

Maximum Rated Flow ..... 6.0 GPM

Shuttling Pressure ..... 15 psid (Minimum) 40 psid (Maximum)

Leakage: (N to E or E to N) ..... 5 Drops/Hour (Maximum)  
 at 5000 psid after 2 Minute wait

Screen Hole Size ..... 0.008"

Nominal System Pressure ..... up to 5000 psi

Nominal Weight ..... 5.0 grams

*Valve performance on MIL-PRF-83282 at 85°F. 1 drop = 50  $\mu$ L*

PIN

INSERT

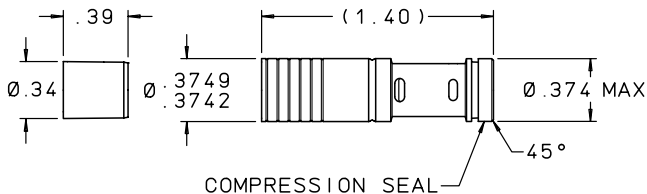

## MATERIALS

PART	MATERIAL	SPECIFICATION
Body	15-5PH Cres	AMS 5659
Poppet	440C Cres	AMS 5630
Spring	17-7PH Cres	AMS 5678
Compression Seal	Polyimide	—
Pin	17-4PH Cres	AMS 5643

Finish: All Cres Parts Passivated.

All Aluminum Parts Alodined.

Pins are prewaxed. Do not degrease. Do not lubricate.

SHBA3750375L

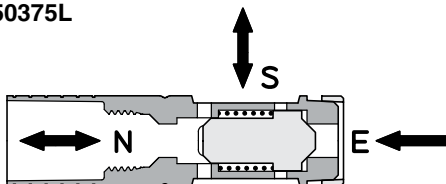

SHBA3755375L

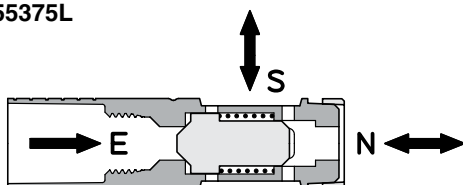

### INSTALLATION HOLE

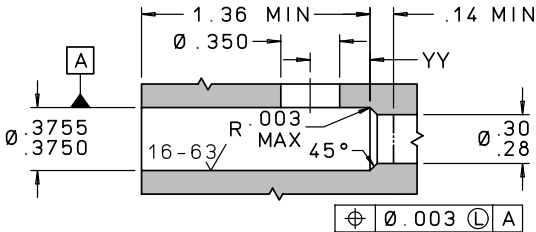

YY = .356 SHBA3750375L / .326 SHBA3755375L

### INSTALLATION AND EXTRACTION

Tool Set Part Number ..... CUTA3750406C  
 Procedures ..... See **Pages N31 – N32**  
 Replacement Pin Part Number ..... SHBA3750003A  
 Replacement Compression Seal  
 Part Number ..... SVDA3750009A  
 For boss size see **page N24**. For oversize see **page N28**.



### PERFORMANCE

Flow Rate:  
 Normal (N to S or S to N) ..... 2 GPM min. at 50 psid  
 (75 Lohms max. restriction)  
 Emergency (E to S) ..... 2 GPM min. at 50 psid  
 (75 Lohms max. restriction)  
 Shuttlng Pressure: ..... 15 psid (minimum)  
 40 psid (maximum)  
 Leakage:  
 (N to E or E to N at 5000 psid) ..... 5 drops/hour (maximum)  
 after 2 minute wait  
 Nominal System Pressure: ..... up to 5000 psi  
 Nominal Weight: ..... 12 grams  
 Valve performance on MIL-PRF-83282 at 85°F. 1 drop = 50µL

PIN

INSERT

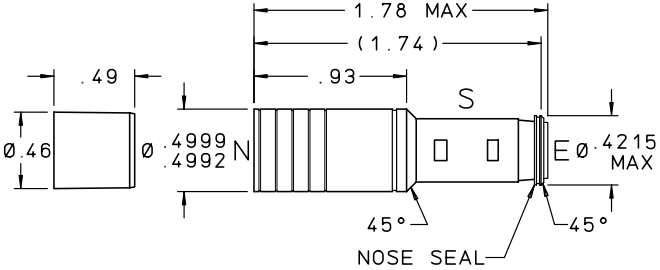

**MATERIALS**

PART	MATERIAL	SPECIFICATION
Body – Rear	304L Cres	AMS 5647
Body – Front	15-5PH Cres	AMS 5659
Pin	17-4PH Cres	AMS 5643
Spring	17-7PH Cres	AMS 5678
Poppet	440C Cres	AMS 5630
Nose Seal	6061-T6 Al	AMS 4117

*Finish: All Cres Parts Passivated.  
All Aluminum Parts Alodined.*

*Pins are prewaxed. Do not degrease. Do not lubricate.*

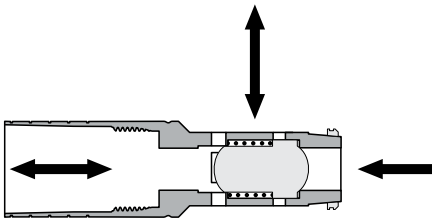

SHBA5000335L

## INSTALLATION HOLE

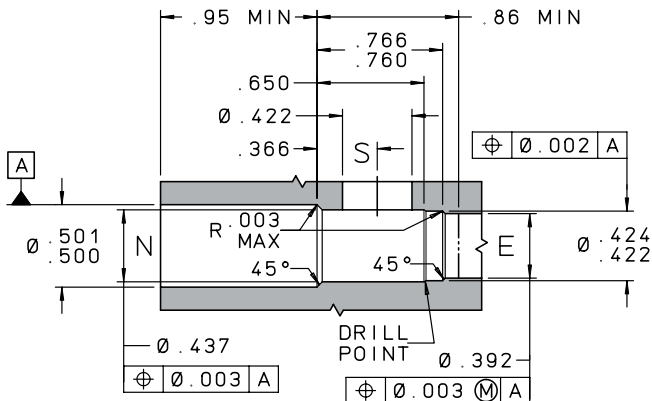

## INSTALLATION AND EXTRACTION

Tool Set Part Number ..... CUTA5000237C

Procedures ..... See [Pages N31 – N32](#)

Replacement Pin Part Number..... CHFA5000003A

Replacement Nose Seal Part Number .... SVBA5000009B

*For boss size see [page N24](#). For oversize see [page N28](#).*

## PERFORMANCE

### Flow Rate:

Normal (N to S or S to N)..... 35 Lohms Max. Restriction  
(4.4 GPM min. at 50 psid)

Emergency (E to S)..... 35 Lohms Max. Restriction  
(4.4 GPM min. at 50 psid)

Maximum Rated Flow .....20.4 GPM

Shuttling Pressure..... 15 psid (Minimum) 40 psid (Maximum)

Leakage: (N to E or E to N)..... 5 Drops/Hour (Maximum)  
at 5000 psid after 2 Minute wait

Nominal System Pressure ..... up to 5000 psi

Nominal Weight ..... 17 grams

*Valve performance on MIL-PRF-83282 at 85°F. 1 drop = 50  $\mu$ L*

PIN

INSERT

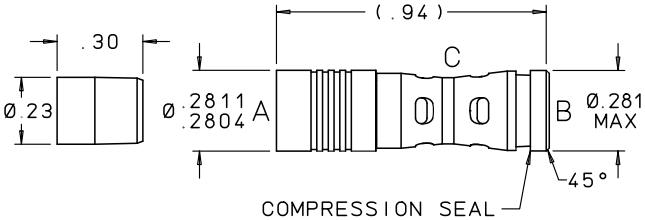

**MATERIALS**

PART	MATERIAL	SPECIFICATION
Body – Rear	15-5PH Cres	AMS 5659
Body – Front	13-8 MO	AMS 5629
Pin	15-5PH	AMS 5659
Spring	17-7PH Cres	AMS 5678
Poppet	440C Cres	AMS 5630
Compression Seal	Polyimide	—
Balls	440C Cres	AMS 5630

*Finish: All Cres Parts Passivated.*

*Pins are prewaxed. Do not degrease. Do not lubricate.*

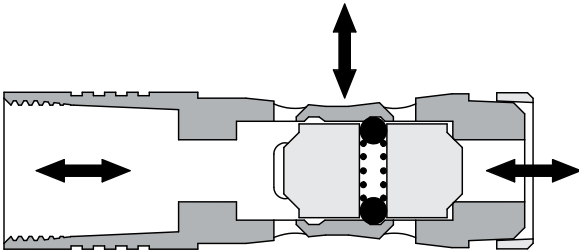

SVDA2812313D

## INSTALLATION HOLE

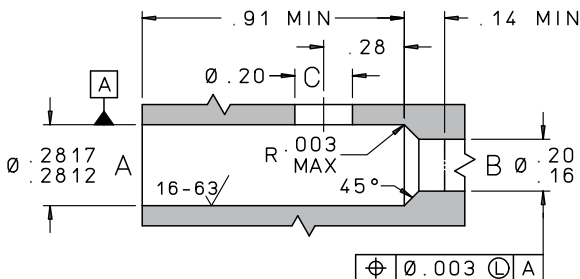

## INSTALLATION AND EXTRACTION

Tool Set Part Number ..... CUTA2810114C

Procedures ..... See [Pages N31 – N32](#)

Replacement Pin Part Number ..... SHBA2810003A

Replacement Compression Seal

Part Number ..... SVDA2810009A

*For boss size see [page N24](#). For oversize see [page N28](#).*

G

## PERFORMANCE

Flow Rate:

(A to C or B to C)..... 130 Lohms Max. Restriction  
(1.2 GPM min. at 50 psid)

Shuttling Pressure..... 25 psid (Minimum) 100 psid (Maximum)

Leakage: (A to B or B to A) ..... 1 Drop/Hour (Maximum)  
at 1000-4000 psid) after 2 Minute wait

Leakage: (A to B or B to A) ..... 1 Drop/Minute (Maximum)  
at 5 psid) after 2 Minute wait

Nominal System Pressure ..... up to 4000 psi

Nominal Weight ..... 4.0 grams

*Valve performance on MIL-PRF-83282 at 85°F. 1 drop = 50  $\mu$ L*

PIN

INSERT

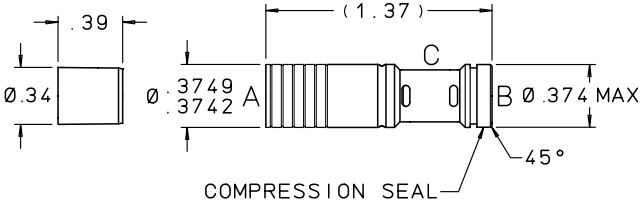

**MATERIALS**

PART	MATERIAL	SPECIFICATION
Body	15-5PH Cres	AMS 5659
Poppet	440C Cres	AMS 5630
Spring	17-7PH Cres	AMS 5678
Balls	440C Cres	AMS 5630
Compression Seal	Polyimide	-
Pin	17-4PH Cres	AMS 5643

*Finish: All Cres Parts Passivated.*

*All Aluminum Parts Alodined.*

*Pins are prewaxed. Do not degrease. Do not lubricate.*

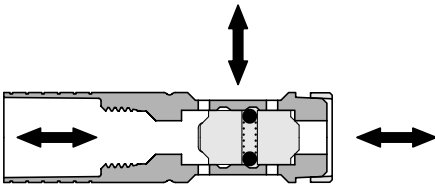

**SVDA3752370L**

### INSTALLATION HOLE

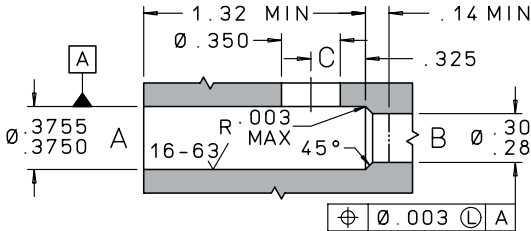

### INSTALLATION AND EXTRACTION

Tool Set Part Number ..... CUTA3750406C  
 Procedures ..... See **Pages N31 – N32**  
 Replacement Pin Part Number ..... SHBA3750003A  
 Replacement Compression Seal  
 Part Number ..... SVDA3750009A  
*For boss size see **page N24**. For oversize see **page N28**.*



### PERFORMANCE

**Flow Rate:**  
 (A to C or B to C) ..... 2.2 GPM min. at 50 psid  
 (70 Lohms max. restriction)  
**Shuttling Pressure:**.....25 psid (minimum) 100 psid (maximum)  
**Leakage: (A to B or B to A)**  
**Metal Seat:**  
 at 5 psid ..... 1 drop/minute (maximum)  
 after 2 minute wait  
 at 1000 - 5000 psid ..... 1 drop/hour (maximum)  
 after 2 minute wait  
**Nominal System Pressure:** ..... up to 5000 psi  
**Nominal Weight:**..... 12 grams  
*Valve performance on MIL-PRF-83282 at 85°F. 1 drop = 50µL*

PIN

INSERT

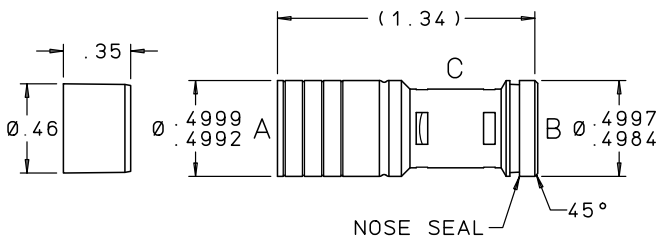

### MATERIALS

PART	MATERIAL	SPECIFICATION
Body – Rear	15-5PH Cres	AMS 5659
Body – Front	15-5PH Cres	AMS 5659
Pin	15-5PH Cres	AMS 5659
Spring	17-7PH Cres	AMS 5678
Poppet	440C Cres	AMS 5630
Compression Seal	Polyamide-Imide	ASTM-D-5204
Balls	440C Cres	AMS 5630

*Finish: All Cres Parts Passivated.*

*Pins are prewaxed. Do not degrease. Do not lubricate.*

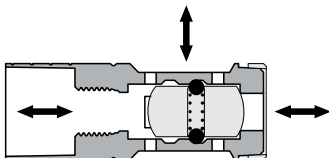

SVDA5002330L

## INSTALLATION HOLE

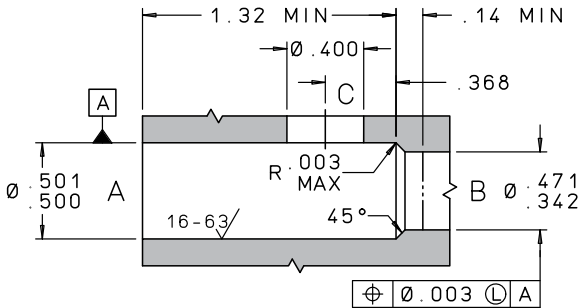

## INSTALLATION AND EXTRACTION

Tool Set Part Number ..... CUTA5000337C  
 Procedures ..... See **Pages N31 – N32**  
 Replacement Pin Part Number..... SVBA5000003A  
 Replacement Compression  
 Seal Part Number..... SVDA5000009A  
*For boss size see **page N24**. For oversize see **page N28**.*



## PERFORMANCE

Flow Rate:  
 (A to C or B to C) ..... 30 Lohms Max. Restriction  
 (5.1 GPM min. at 50 psid)  
 Shuttlng Pressure..... 25 psid (Minimum) 100 psid (Maximum)  
 Leakage: (A to B or B to A) ..... 1 Drop/Hour (Maximum)  
 at 1000-5000 psid) after 2 Minute wait  
 Leakage: (A to B or B to A) ..... 1 Drop/Minute (Maximum)  
 at 5 psid) after 2 Minute wait  
 Nominal System Pressure..... up to 5000 psi  
 Nominal Weight ..... 17 grams

*Valve performance on MIL-PRF-83282 at 85°F. 1 drop = 50 µL*

PIN

INSERT

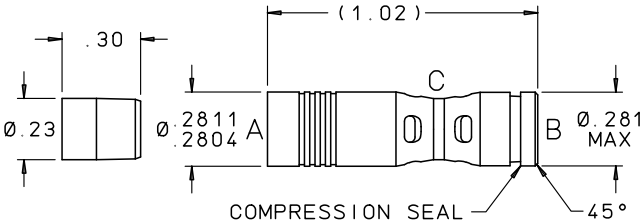

**MATERIALS**

PART	MATERIAL	SPECIFICATION
Body – Rear	15-5PH Cres	AMS 5659
Body – Front	15-5PH Cres	AMS 5659
Body – Center	13-8 MO	AMS 5629
Pin	15-5PH Cres	AMS 5659
Spring	17-7PH Cres	AMS 5678
Seat Retainers	15-5PH Cres	AMS 5659
Seats	Polyimide	—
Poppet	440C Cres	AMS 5630
Compression Seal	Polyimide	—
Balls	440C Cres	AMS 5630

*Finish: All Cres Parts Passivated.*

*Pins are prewaxed. Do not degrease. Do not lubricate.*

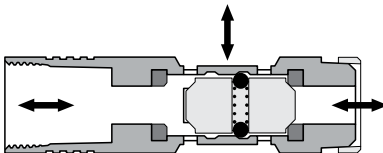

**SVDA2811313D**

## INSTALLATION HOLE

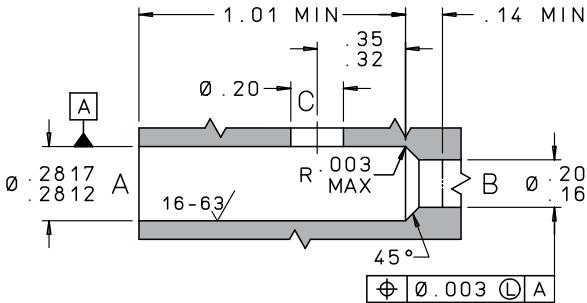

## INSTALLATION AND EXTRACTION

Tool Set Part Number ..... CUTA2810114C  
 Procedures ..... See **Pages N31 – N32**  
 Replacement Pin Part Number..... SHBA2810003A  
 Replacement Compression  
 Seal Part Number..... SVDA2810009A

*For boss size see **page N24**. For oversize see **page N28**.*



## PERFORMANCE

Flow Rate:  
 (A to C or B to C) ..... 130 Lohms Max. Restriction  
 (1.2 GPM min. at 50 psid)  
 Shuttling Pressure.....25 psid (Minimum) 100 psid (Maximum)  
 Leakage: (A to B or B to A ..... Zero Bubbles/Min. of N<sub>2</sub>  
 at 500-4000 psid) ..... after 2 Minute wait  
 Nominal System Pressure..... up to 4000 psi  
 Nominal Weight ..... 4.0 grams

*Valve performance on MIL-PRF-83282 at 85°F. 1 drop = 50 µL*

PIN

INSERT

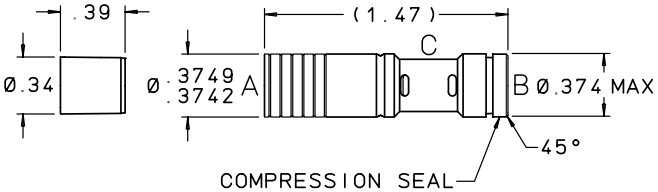

**MATERIALS**

PART	MATERIAL	SPECIFICATION
Body	15-5PH Cres	AMS 5659
Poppet	440C Cres	AMS 5630
Spring	17-7PH Cres	AMS 5678
Balls	440C Cres	AMS 5630
Compression Seal	Polyimide	-
Pin	17-4PH Cres	AMS 5643
Seats	Polyimide	-
Seat Retainers	15-5PH Cres	AMS 5659

*Finish: All Cres Parts Passivated.*

*All Aluminum Parts Alodined.*

*Pins are prewaxed. Do not degrease. Do not lubricate.*

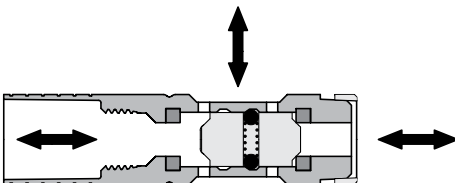

**SVDA3751370L**

### INSTALLATION HOLE

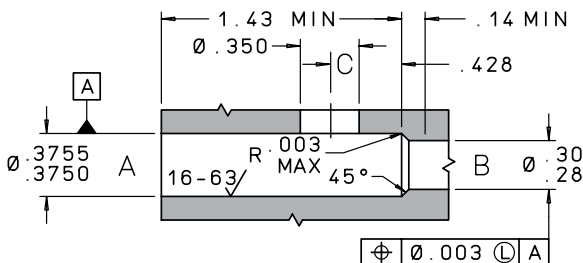

### INSTALLATION AND EXTRACTION

Tool Set Part Number ..... CUTA3750406C  
 Procedures ..... See **Pages N31 – N32**  
 Replacement Pin Part Number ..... SHBA3750003A  
 Replacement Compression Seal  
 Part Number ..... SVDA3750009A  
*For boss size see **page N24**. For oversize see **page N28**.*



### PERFORMANCE

Flow Rate:  
 (A to C or B to C) ..... 2.2 GPM min. at 50 psid  
 (70 Lohms max. restriction)

Shuttling Pressure:.....25 psid (minimum) 100 psid (maximum)

Leakage: (A to B or B to A)  
 Polymeric Seat:  
 at 500 - 5000 psid ..... Zero bubbles/minute of N<sub>2</sub>  
 after 2 minute wait

Nominal System Pressure: ..... up to 5000 psi

Nominal Weight:..... 13 grams

*Valve performance on MIL-PRF-83282 at 85°F. 1 drop = 50µL*

**PIN**

**INSERT**

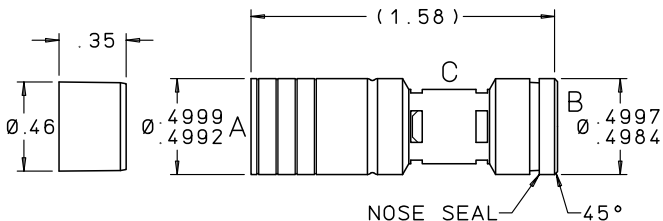

## MATERIALS

PART	MATERIAL	SPECIFICATION
Body – Rear	15-5PH Cres	AMS 5659
Body – Front	15-5PH Cres	AMS 5659
Body – Center	15-5PH Cres	AMS 5659
Pin	15-5PH Cres	AMS 5659
Spring	17-7PH Cres	AMS 5678
Seat Retainers	15-5PH Cres	AMS 5659
Seats	Polyimide	—
Poppet	440C Cres	AMS 5630
Compression Seal	Polyamide-Imide	ASTM D 5204
Balls	440C Cres	AMS 5630

*Finish: All Cres Parts Passivated.*

*Pins are prewaxed. Do not degrease. Do not lubricate.*

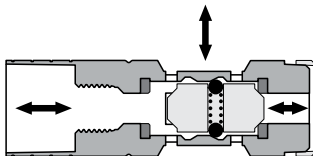

**SVDA5001335L**

## INSTALLATION HOLE

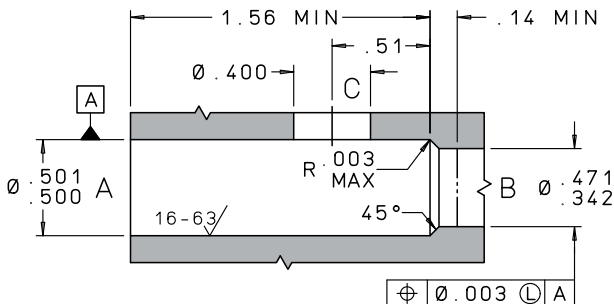

## INSTALLATION AND EXTRACTION

Tool Set Part Number .....CUTA5000337C  
 Procedures ..... See **Pages N31 – N32**  
 Replacement Pin Part Number.....SVBA5000003A  
 Replacement Compression  
 Seal Part Number..... SVDA5000009A  
*For boss size see **page N24**. For oversize see **page N28**.*

## PERFORMANCE

Flow Rate:  
 (A to C or B to C)..... 35 Lohms Max. Restriction  
 (4.4 GPM min. at 50 psid)  
 Shuttling Pressure.....25 psid (Minimum) 100 psid (Maximum)  
 Leakage: (A to B or B to A ..... Zero Bubbles/Min. of N<sub>2</sub>  
 at 500-5000 psid) ..... after 2 Minute wait  
 Nominal System Pressure ..... up to 5000 psi  
 Nominal Weight ..... 17 grams  
*Valve performance on MIL-PRF-83282 at 85°F. 1 drop = 50 µL*

PIN

INSERT

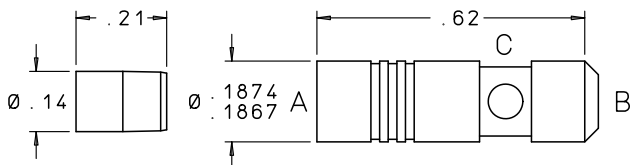

G

## MATERIALS

PART	MATERIAL	SPECIFICATION
Body – Rear	303 Cres	QQ-S-763
Body – Front	303 Cres	QQ-S-763
Pin	17-4PH Cres	AMS 5643
Ball	440C Cres	AMS 5630

*Finish: All Cres Parts Passivated.  
Pins are prewaxed. Do not degrease. Do not lubricate.*

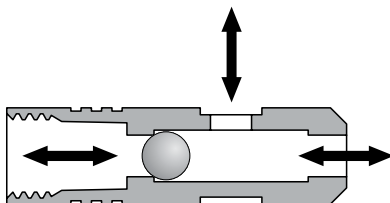

SVSA1870135D

## INSTALLATION HOLE

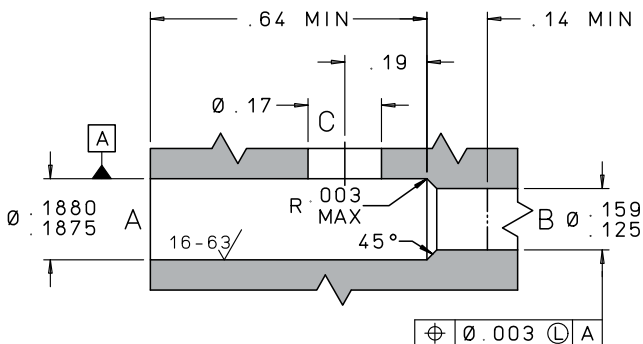

## INSTALLATION AND EXTRACTION

Tool Set Part Number ..... CUTA1870104C  
 Procedures ..... See **Pages N31 – N32**  
 Replacement Pin Part Number..... JETA1870004A

*For boss size see **page N24**. For oversize see **page N28**.*



## PERFORMANCE

### Flow Rate:

(A to C or B to C)..... 350 Lohms Max. Restriction  
 (0.4 GPM min. at 50 psid)

Shuttling Pressure..... 1 psid (Maximum)

Leakage: (A to B or B to A ..... 1 ml/Minute (Maximum)  
 at 3000 psid) after 2 Minute wait

Nominal System Pressure ..... up to 3000 psi

Nominal Weight ..... 1.5 grams

*Valve performance on MIL-PRF-83282 at 85°F. 1 drop = 50  $\mu\text{L}$*

PIN

INSERT

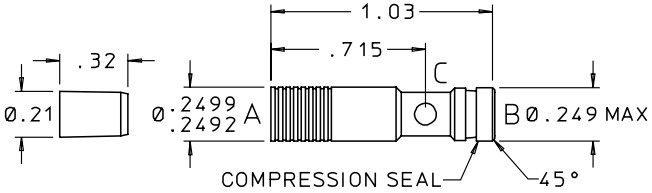

### MATERIALS

PART	MATERIAL	SPECIFICATION
Body – Rear	304 Cres	AMS 5639
Body – Front	304 Cres	AMS 5639
Pin	17-4PH Cres	AMS 5643
Ball	440C Cres	AMS 5630
Compression Seal	Polyamide-Imide	ASTM D 5204

*Finish: All Cres Parts Passivated.*

*Pins are prewaxed. Do not degrease. Do not lubricate.*

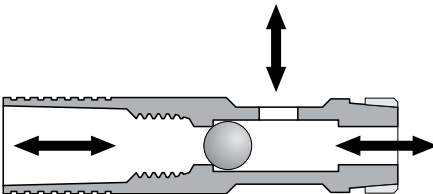

SVSA2500320D



PIN

INSERT

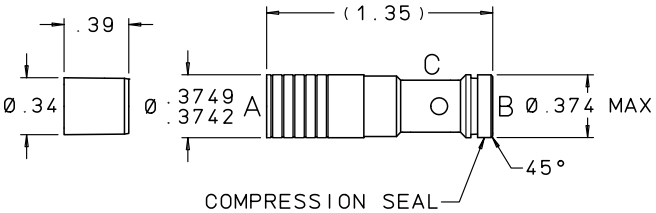

G

MATERIALS		
PART	MATERIAL	SPECIFICATION
Body	15-5PH Cres	AMS 5659
Ball	440C Cres	AMS 5630
Compression Seal	Polyimide	-
Polyimide Pin	17-4PH Cres	AMS 5643

Finish: All Cres Parts Passivate/AMS 2700.  
 Pins are prewaxed. Do not degrease. Do not lubricate.

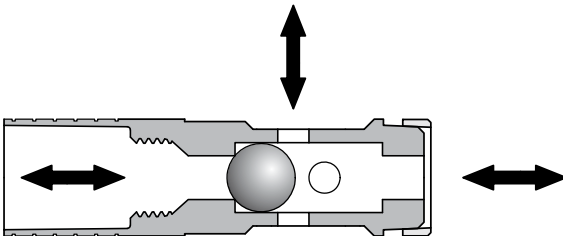

SVSA3750370L

### INSTALLATION HOLE

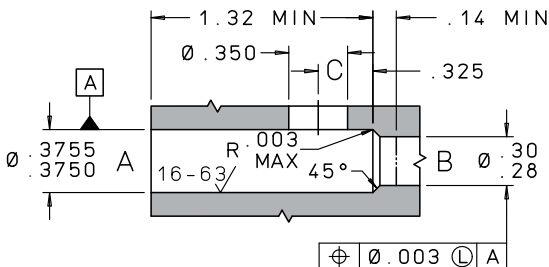

### INSTALLATION AND EXTRACTION

Tool Set Part Number ..... CUTA3750406C  
 Procedures ..... See **Pages N31 – N32**  
 Replacement Pin Part Number ..... SHBA3750003A  
 Replacement Compression Seal  
 Part Number ..... SVDA3750009A  
*For boss size see **page N24**. For oversize see **page N28**.*



### PERFORMANCE

Flow Rate:  
 (A to C or B to C) ..... 70 Lohms Maximum Restriction  
 Shuttlng Pressure ..... 1 psid (Maximum)  
 Leakage: (A to B or B to A ..... 1ml/Minute (Maximum)  
 at 5000 psid) ..... after 2 Minute wait  
 Nominal System Pressure ..... up to 5000 psi  
 Nominal Weight ..... 12 grams

*Valve performance on MIL-PRF-83282 at 85°F. 1 drop = 50  $\mu$ L*

PIN

INSERT

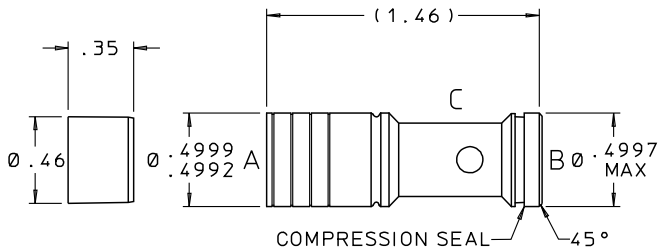

MATERIALS		
PART	MATERIAL	SPECIFICATION
Body – Rear	15-5PH Cres	AMS 5659
Body – Front	15-5PH Cres	AMS 5659
Pin	15-5PH Cres	AMS 5659
Ball	440C Cres	AMS 5630
Compression Seal	Polyamide-Imide	ASTM D 5204

*Finish: All Cres Parts Passivated.*

*Pins are prewaxed. Do not degrease. Do not lubricate.*

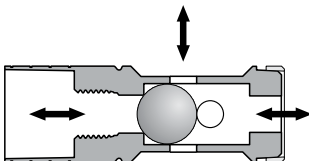

SVSA5000330L



PIN

INSERT

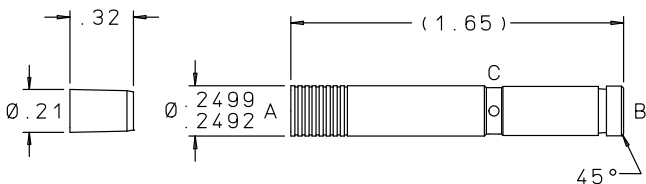

### MATERIALS

PART	MATERIAL	SPECIFICATION
Body Rear	304 Cres	AMS 5639
Body Center	15-5PH Cres	AMS 5659
Body Front	304 Cres	AMS 5639
Poppets	15-5PH Cres	AMS 5659
Pin	17-4 PH	AMS 5643
Compression Seal	Polyimide	—

*Finish: All Cres Parts Passivated.*

*All Aluminum Parts Alodined.*

*Pins are prewaxed. Do not degrease. Do not lubricate.*

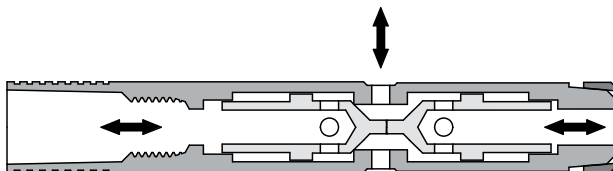

SVIA2500326D

## INSTALLATION HOLE

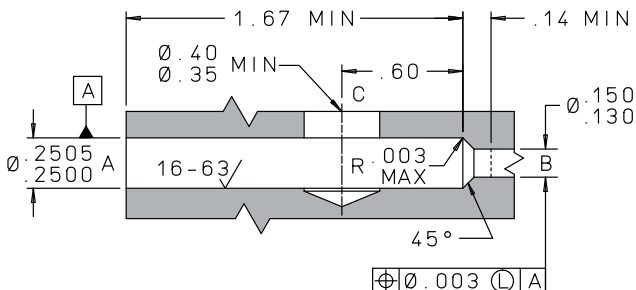

## INSTALLATION AND EXTRACTION

Tool Set Part Number ..... CUTX0503050B  
 Procedures ..... See **Pages N31 – N32**  
 Replacement Pin Part Number ..... CHFA2500003A  
 Replacement Compression Seal  
 Part Number ..... CPRA2500109A  
*For boss size see **page N24**. For oversize see **page N28**.*

## PERFORMANCE

Unbalanced Flow: (290 Lohms maximum)  
 Port A to Port C (Port B Closed).... 0.31 GPM min. at  
 25 psid ( $P_B \geq 1.25 \times P_A$ )  
 Port B to Port C (Port A Closed).... 0.31 GPM min. at  
 25 psid ( $P_A \geq 1.25 \times P_B$ )  
 Anti-Cavitation Flow: (260 Lohms maximum)  
 Port C to Port A..... 0.35 GPM min. at 25 psid  
 Port C to Port B..... 0.35 GPM min. at 25 psid  
 Maximum Leakage:  
 Port A to Ports C & B (Ports C & B at atmosphere)  
 ..... 5 drops/minute at 50 psid  
 Port B to Ports C & A (Ports C & A at atmosphere)  
 ..... 5 drops/minute at 50 psid  
 Nominal System Pressure ..... up to 5000 psi  
 Nominal Weight..... 8 grams

*Valve performance on MIL-PRF-83282 at 85 °F 1 drop = 50 uL*

PIN

INSERT

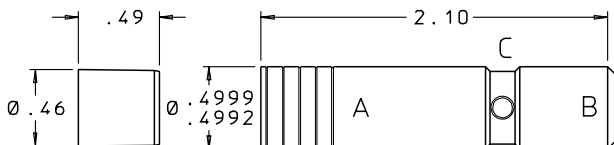

## MATERIALS

PART	MATERIAL	SPECIFICATION
Body	304 Cres	AMS 5639
Pin	15-5PH Cres	AMS 5659
Springs	17-7PH Cres	AMS 5678
Spring Seats	304 Cres	AMS 5639
Poppets	15-5PH Cres	AMS 5659

*Finish: All Cres Parts Passivated.*

*Pins are prewaxed. Do not degrease. Do not lubricate.*

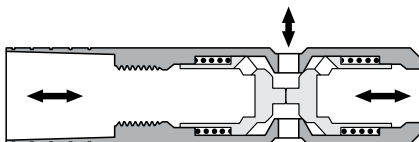

SVIA5000350L

LEE PART NUMBER	FLOW A → C, B → C (at 300 psid)		FLOW C → A, C → B (at 50 psid)	
	LOHMS (Ref.)	GPM ±20%	LOHMS (Ref.)	GPM (Min.)
SVIA5000350L	50	7.5	35	4.4
SVIA5000375L	75	5.0	35	4.4
SVIA5000310D	100	3.8	35	4.4

## INSTALLATION HOLE

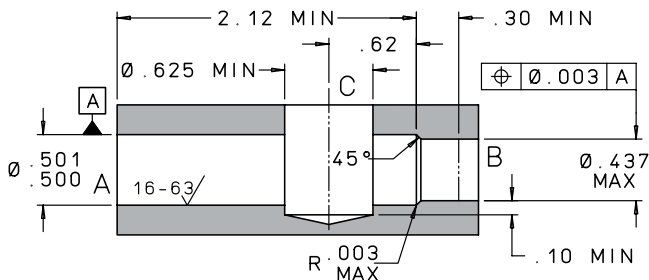

## INSTALLATION AND EXTRACTION

Tool Set Part Number ..... CUTA5000206C  
 Procedures ..... See [Pages N31 – N32](#)  
 Replacement Pin Part Number..... CHFA5000003A

*For boss size see [page N24](#). For oversize see [page N28](#).*

## PERFORMANCE

Shuttling Pressure:

A closed (Flow B → C) .....  $P_A - 6 \geq P_B$   
 B closed (Flow A → C).....  $P_B \geq P_A$

Leakage: (A to C or B to C)..... 10 drops/Minute (Maximum)  
 at 25 psid) ..... after 2 Minute wait

Nominal System Pressure .....up to 5000 psi

Nominal Weight .....32 grams

*Valve performance on MIL-PRF-83282 at 85°F. 1 drop = 50  $\mu$ L*

# Combination & Shut-Off Valves



H

## **PRI / CHEK VALVE**

- Combines function of Lee Chek and Lee PRI in a single compact package
- Wide range of relief flow cracking pressures

## **BYPASS VALVE**

- Hydraulically-actuated pilot-to-close design
- Maximum restriction of 70 Lohms when open

## **FLOW FUSE**

- Stops flow at a specified flow rate
- Multiple configurations to meet a variety of applications

## TABLE OF CONTENTS

<b>PRI/Chek Valves</b>	Pressure relief in one direction, free flow in the other .....2, 4 – 11
<b>Bypass Valves</b>	Normally open with hydraulic pilot-to-close .....3, 12 – 13
<b>Flow Fuses</b>	Custom designed normally open check valve .....3, 14 – 15

### PRI/CHEK VALVES

Lee PRI/Chek Valves combine the function of a reverse flow pressure relief valve in parallel with the function of a check valve with free flow in the forward direction into one easy to install insert. The relief valve function features a rugged Tungsten Carbide ball and a 440C seat for durability and long life. The remaining components are constructed entirely of stainless steel. The valves are available in a range of relief flow cracking pressures for system pressures up to 5,000 psi.

The 281 PRI/Chek Valves are available with or without integral safety screens. The unscreened version has a maximum restriction of 300 Lohms in the free flow direction and is available in 9 different standard relief flow cracking pressures up to 3600 psid. The screened version has a maximum restriction of 550 Lohms in the free flow direction and is available in 15 different standard relief flow cracking pressures up to 5900 psid. The 375 PRI/Chek Valve has a maximum restriction of 220 Lohms in the free flow direction and is available in 7 different standard relief flow cracking pressures up to 5400 psid.

## **BYPASS VALVES**

Lee Bypass Valves are normally open, with a hydraulically-actuated pilot-to-close feature. They are designed to shunt flow across an actuator piston when the system pressure is either shut off or lost. The valve is available in a .375" diameter insert for system pressures up to 4,000 psi. This miniature valve has a maximum restriction of 70 Lohms when fully open and weighs only 16 grams. The metal components are constructed entirely of stainless steel for durability and long life. Similar to Lee Shuttle Valves, Lee Bypass valves include a polyimide compression seal to ensure there is no external leakage across the three port design when properly installed.

## **FLOW FUSES**

Lee Flow Fuses are individually designed to meet custom requirements. The valve design functions as a normally-open check valve. As the flow rate increases beyond a specified value across the valve, a poppet shuts against the valve seat and stops the flow. Custom flow fuses are available in .187, .281, .483, .798 and 1 inch diameters with shut-off flow rates tailored to meet application needs.

# 4

# 281 PRI / Chek Valve

PIN

INSERT

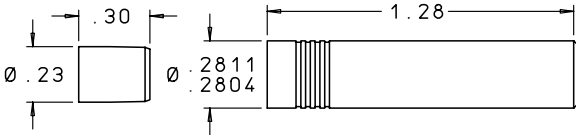

## MATERIALS

PART	MATERIAL	SPECIFICATION
Shuttle Plate	303 CRES	QQ-S-763C
Seat	440C CRES	AMS 5630
Spring Seat	303 CRES	QQ-S-763C
Springs	17-7PH CRES	AMS 5678
Body	15-5PH CRES	AMS 5659
Ball Follower	303 CRES	QQ-S-763C
Tube	17-4PH CRES or 304 CRES	AMS 5643, AMS 5639
Ball	Tungsten Carbide	—
Pin	15-5PH CRES	AMS 5659
Screens	15-5PH CRES	AMS 5659

*Finish: All Cres Parts Passivated.*

*Pins are prewaxed. Do not degrease. Do not lubricate.*

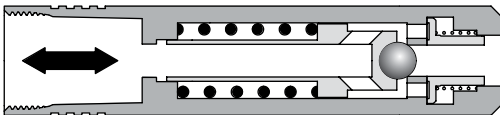
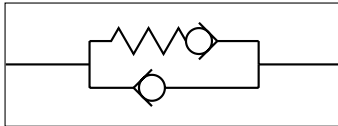

Relief Flow Direction

Free Flow Direction

## INSTALLATION HOLE

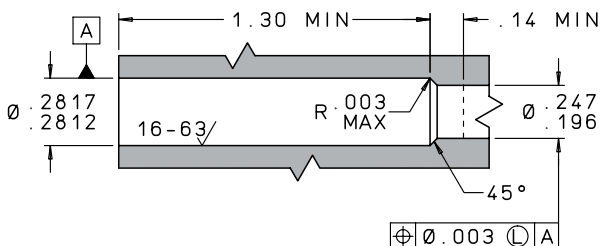

## INSTALLATION AND EXTRACTION

Tool Sets Part Numbers: ..... CUTA2810114C  
 Procedures ..... See **Pages N26 – N30**  
 Replacement Pin Part Number ..... SHBA2810003A

*For boss size see **page N24**. For oversize see **page N28**.*

## PERFORMANCE

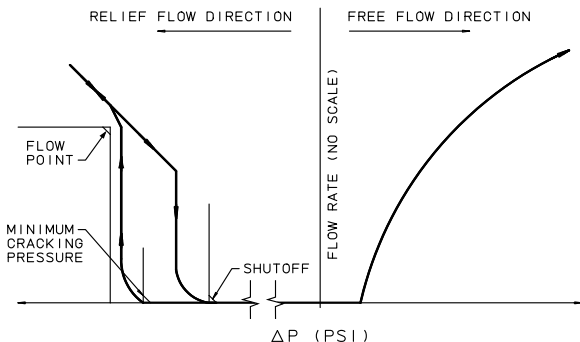
**Relief Flow Direction:**

Leakage at Minimum Cracking Pressure: 10 drops/minute max.

Leakage at Minimum Shutoff Pressure: 10 drops/minute max.

Nominal System Pressure: up to 5000 psi

System Peak Pressure: 6750 psi maximum

Nominal Weight: 8.0 grams unscreened / 9.0 grams screened

Screen Hole Size: 0.008" Nominal

*Valve performance on MIL-PRF-83282 or MIL-PRF-5606 at 85°F±15°F.*

# 6

# 281 Screened PRI/Chek

PIN

INSERT

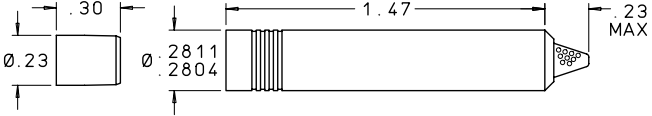

## MATERIALS

PART	MATERIAL	SPECIFICATION
Shuttle Plate	303 CRES	QQ-S-763C
Seat	440C CRES	AMS 5630
Spring Seat	303 CRES	QQ-S-763C
Springs	17-7PH CRES	AMS 5678
Body	15-5PH CRES	AMS 5659
Ball Follower	303 CRES	QQ-S-763C
Tube	17-4PH CRES or 304 CRES	AMS 5643, AMS 5639
Ball	Tungsten Carbide	—
Pin	15-5PH CRES	AMS 5659
Screens	15-5PH CRES	AMS 5659

*Finish: All Cres Parts Passivated.*

*Pins are prewaxed. Do not degrease. Do not lubricate.*

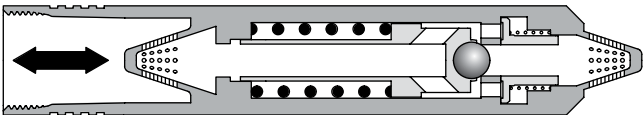
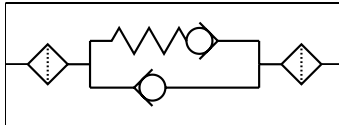

Relief Flow Direction

Free Flow Direction

## INSTALLATION HOLE

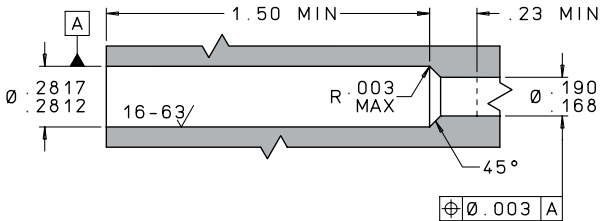

## INSTALLATION AND EXTRACTION

Tool Sets Part Numbers ..... CUTA2810114C  
 Procedures ..... See [Pages N26 – N30](#)  
 Replacement Pin Part Number..... SHBA2810003A

For boss size see [page N24](#). For oversize see [page N28](#).

## PERFORMANCE

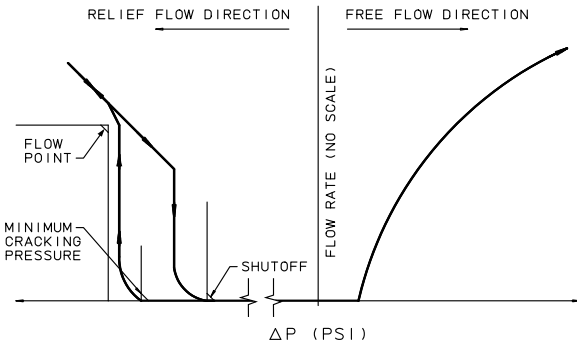

### Relief Flow Direction:

Leakage at Minimum Cracking Pressure: 10 drops/minute max.

Leakage at Minimum Shutoff Pressure: 10 drops/minute max.

Nominal System Pressure: up to 5000 psi

System Peak Pressure: 6750 psi maximum

Nominal Weight: 8.0 grams unscreened / 9.0 grams screened

Screen Hole Size: 0.008" Nominal

Valve performance on MIL-PRF-83282 or MIL-PRF-5606 at  $85^\circ F \pm 15^\circ F$ .

LEE PART NUMBER	RELIEF FLOW DIRECTION				
	MINIMUM CRACKING PRESSURE (psid)	FLOW POINT			
		MAX. LOHM RATE	MIN. FLOW (gpm)	AT (psid)	
<b>UNSCREENED .281 PRI/CHEK VALVE</b>					
PFRA2810500L	500	220	2.4	625	
PFRA2810100D	1000	220	3.4	1250	
PFRA2810120D	1200	220	3.7	1500	
PFRA2810200D	2000	220	4.8	2500	
PFRA2810220D	2200	220	5.0	2750	
PFRA2810240D	2400	220	5.2	3000	
PFRA2810300D	3000	220	5.9	3750	
PFRA2810320D	3200	280	4.8	4000	
PFRA2810360D	3600	280	5.1	4500	
<b>SCREENED .281 PRI/CHEK VALVE</b>					
PFRA2815500L	500	350	1.5	625	
PFRA2815100D	1000	350	2.2	1250	
PFRA2815120D	1200	350	2.4	1500	
PFRA2815200D	2000	350	3.1	2500	
PFRA2815220D	2200	350	3.2	2750	
PFRA2815240D	2400	350	3.4	3000	
PFRA2815300D	3000	1500	0.9	3600	
PFRA2815320D	3200	1500	0.9	3850	
PFRA2815340D	3400	1500	0.95	4050	
PFRA2815420D	4200	1500	1.0	4750	
PFRA2815450D	4500	1500	1.0	5100	
PFRA2815470D	4700	1500	1.1	5300	
PFRA2815520D	5200	1500	1.1	5800	
PFRA2815570D	5700	1500	1.2	6350	
PFRA2815590D	5900	1500	1.2	6600	

RELIEF FLOW DIRECTION		FREE FLOW DIRECTION	
	MINIMUM SHUTOFF PRESSURE (psid)	CRACKING PRESSURE (psid)	LOHM RATE AT 25 PSID AND GREATER
	425	5 ± 3	300 max
	850	5 ± 3	300 max
	1025	5 ± 3	300 max
	1700	5 ± 3	300 max
	1850	5 ± 3	300 max
	2050	5 ± 3	300 max
	2550	5 ± 3	300 max
	2700	5 ± 3	300 max
	3050	5 ± 3	300 max
	425	5 ± 3	550 max
	850	5 ± 3	550 max
	1025	5 ± 3	550 max
	1700	5 ± 3	550 max
	1850	5 ± 3	550 max
	2050	5 ± 3	550 max
	2850	5 ± 3	550 max
	3000	5 ± 3	550 max
	3200	5 ± 3	550 max
	3700	5 ± 3	550 max
	4000	5 ± 3	550 max
	4200	5 ± 3	550 max
	4550	5 ± 3	550 max
	5000	5 ± 3	550 max
	5200	5 ± 3	550 max

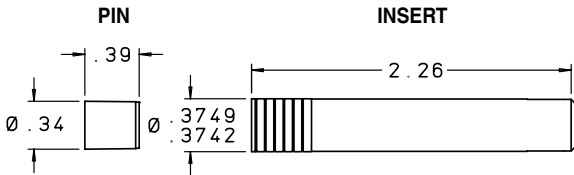

### MATERIALS

PART	MATERIAL	SPECIFICATION
Shuttle Plate	304 CRES	AMS 5639
Seat	440C CRES	AMS 5630
Spring Seat	15-5PH CRES	AMS 5659
Springs	17-7PH CRES	AMS 5678
Retainer	15-5PH CRES	AMS 5659
Shim	17-7PH CRES	AMS 5529
Body	304 CRES	AMS 5639
Ball Follower	304 CRES	AMS 5639
Tube	13-8 MO CRES	AMS 5629
Ball	Tungsten Carbide	—
Orifice Plate	304 CRES	AMS 5639
Pin	17-4PH CRES	AMS 5643

Finish: All Cres Parts Passivated.

Pins are prewaxed. Do not degrease. Do not lubricate.

LEE PART NUMBER	RELIEF FLOW DIRECTION				FREE FLOW DIRECTION		
	MIN. CRACK- ING PRES- SURE (psid)	FLOW POINT			MIN. SHUT- OFF PRES- SURE (psid)	CRACK- ING PRES- SURE (psid)	LOHM RATE AT 25 PSID AND GREATER
		LOHM RATE	MIN. FLOW (gpm)	AT (psid)			
PFRA3750300D	3000	400	3.7	3850	2850	5 ± 3	220 max
PFRA3750320D	3200	400	3.8	4050	3000	5 ± 3	220 max
PFRA3750340D	3400	400	3.9	4250	3200	5 ± 3	220 max
PFRA3750420D	4200	400	4.0	5250	4000	5 ± 3	220 max
PFRA3750440D	4400	400	4.1	5400	4200	5 ± 3	220 max
PFRA3750520D	5200	400	4.9	6550	5000	5 ± 3	220 max
PFRA3750540D	5400	400	5.0	6750	5200	5 ± 3	220 max

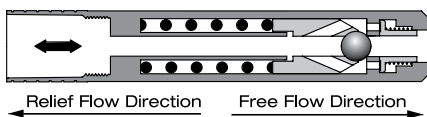
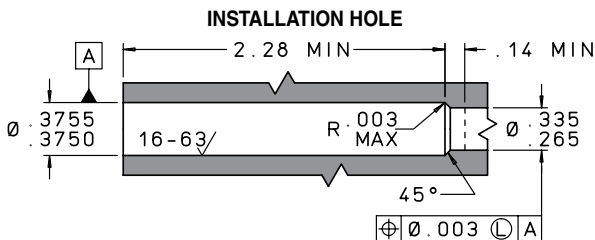

## INSTALLATION AND EXTRACTION

Tool Sets Part Numbers ..... See CUTA3750514C  
 Procedures ..... See [Pages N26 – N30](#)  
 Replacement Pin Part Number..... See PHRA3750003A  
*For boss size see [page N24](#). For oversize see [page N28](#).*

## PERFORMANCE

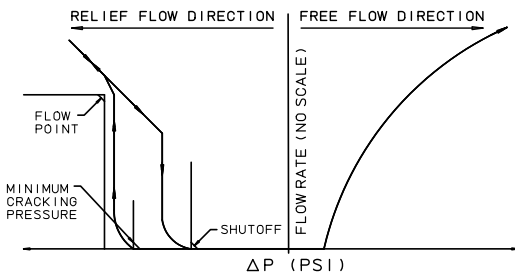

### Relief Flow Direction:

Leakage at Minimum Cracking Pressure: ..... 2 mL/min max.  
 Leakage at Minimum Shutoff Pressure: ..... 2 mL/min max.  
 Restriction at Min. Recommended Valve Lift: ... 1500 Lohms  
 Nominal System Pressure ..... up to 5000 psi  
 System Peak Pressure: ..... 6750 psi max.  
 Nominal Weight..... 24 grams  
*Valve performance on MIL-PRF-83282 or MIL-PRF-5606 at 85°F±15°F.*

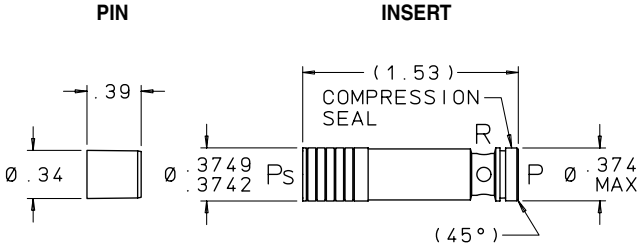

## MATERIALS

PART	MATERIAL	SPECIFICATION
Body	304 Cres	AMS 5639
Retainer	15-5PH Cres	AMS 5659
Poppet Seal	GFP with Hastelloy Spring	—
Poppet	15-5PH Cres	AMS 5659
Spring	17-7PH Cres	AMS 5678
Compression Seal	Polyimide	—
Pin	17-4PH Cres	AMS 5643

*Finish: All Cres Parts Passivated.*

*Pins are prewaxed. Do not degrease. Do not lubricate.*

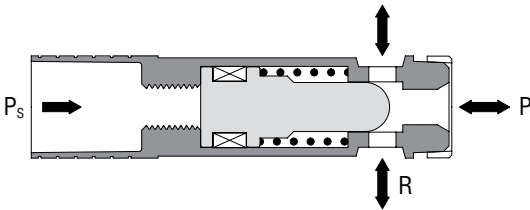

**BPOA3750104H**

## INSTALLATION AND EXTRACTION

- Tool Set Part Number: ..... CUTX0509150B  
 Replacement Pin Part Number: ..... PHRA3750003A  
 Replacement Compression Seal Part Number: ..... SVDA3750009A  
 Procedures:..... See **Pages N31 – N32**  
 For Boss Size: ..... See **Page N24**  
 For Oversize: ..... See **Page N28**

# 375 Bypass Valve

# 13

## INSTALLATION HOLE

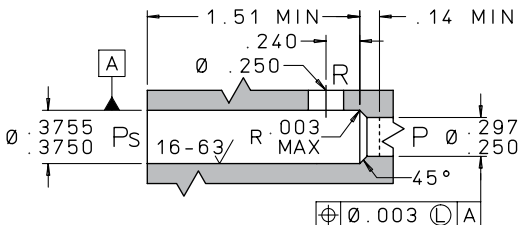

## PERFORMANCE

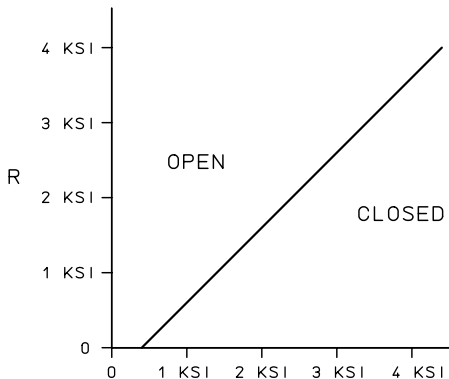

$P$  = System Pressure

$P_s$  &  $P$

$R$  = Return Pressure

$P_s$  = Pilot Port Pressure

Normally Open:

Fully Open Lohm Rate ( $P_s \leq 50$  psid): 70 Lohms maximum

Piloted Closed:

Fully Closed When  $P_s - R \geq 400$  psi ( $P_s = P$ )

Combined Leakage from  $P_s$  and  $P$  to  $R$ : 1 drop/minute maximum

Nominal System Pressure: up to 4000 psi

Nominal Weight: 16 grams

Valve performance on MIL-PRF-83282 at  $85^\circ\text{F} \pm 15^\circ\text{F}$ . 1 drop = 50  $\mu\text{L}$

# H

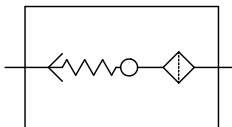

Lee Flow Fuses are individually designed to meet the customer's specific requirements. A flow fuse functions as a normally-open check valve. As the flow rate increases beyond a specified value across the valve, a ball or poppet shuts against the valve seat and stops the flow. When in the open position, the size of the valve is typically chosen to have a minimum pressure loss at the system's normal flow rate. The shut-off flow rate is tailored to meet the application's extreme flow requirement.

Flow fuses are found throughout critical hydraulic systems. In the event of a system breach, the fuse will sense an increase in flow rate and shut-off, preserving hydraulic power and functions upstream of the fuse. A flow fuse can also function as a vent valve to purge trapped air or vapor out of fluidic system, such as a fuel system during engine start-up.

## H

Materials used are typically stainless steel, but can be tailored to specific requirements suitable for system pressures up to 15,000 psi. Insert style flow fuses are available in .187, .281 and .375 inch diameters with the fused flow direction available in forward and reverse. Cartridge style flow fuses are available in .295, .483, .798 and .989 inch diameters. A Zero Leak version using an elastomeric seat is also available.

### INSERT STYLE

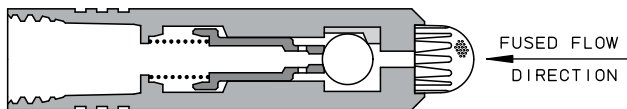

APPROXIMATE SIZE (inches)	MINIMUM AVAILABLE OPEN LOHM RATE	TYPICAL MAX. LEAKAGE
Ø .187 x 0.8	1500 Lohms	1 drop/minute
Ø .281 x 1.2	400 Lohms	1 drop/minute
Ø .375 x 1.5	175 Lohms	5 drops / minute

## CARTRIDGE STYLE

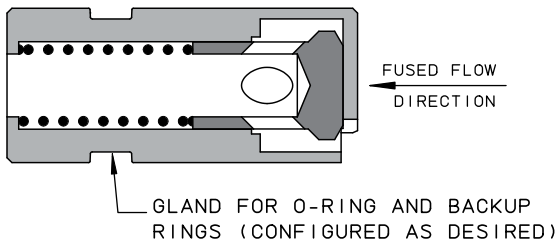

APPROXIMATE SIZE (inches)	MINIMUM AVAILABLE OPEN LOHMS RATE	TYPICAL MAX. LEAKAGE
Ø .295 x 0.7	100 Lohms	1 mL/minute
Ø .483 x 1.2	20 Lohms	1 mL/minute
Ø .798 x 1.6	10 Lohms	2 mL/minute
Ø .989 x 2.0	7 Lohms	2 mL/minute

H

## ZERO LEAK

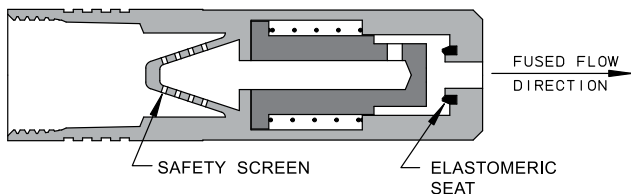

APPROXIMATE SIZE (inches)	MINIMUM AVAILABLE OPEN LOHMS RATE	TYPICAL MAX. LEAKAGE
Ø.281 x 1.0	600 Lohms	0 drops/minute

# Lee Safety Screens





- Simple, Economical Construction
- 6 Methods of Retention for Design Flexibility
- All Stainless Steel Construction
- Hole Sizes from .0008" to .062"



- Rugged, High Strength, One-Piece Design
- No Burst or Collapse up to 7500 psid Fully Clogged
- Machined and Drilled from Solid Bar Stock
- High Contamination Carrying Capacity for Maximum Protection
- Low Lohm, High Flow Capability
- Over 400 Standard Versions for Design Flexibility
- Hole Sizes from .002" to .020"

**TABLE OF CONTENTS****Introduction**

Relative Rating System for Safety Screens (ROB Numbers) .....	3 – 7
Filters vs Safety Screens .....	8
Clogging .....	9
Location .....	10
Pressure Ratings .....	10 – 11
Hole Sizes .....	12
Standard Lee Hole Sizes .....	13
Open Area .....	13
Cold Start .....	14
Construction Methods .....	15 – 17
Installation Techniques .....	18 – 21

**Etched Safety Screens**

Flange Mounted - FSJ .....	24 – 41
Boss Mounted - FSB .....	46 – 54
Insert Retained - FSC .....	58 – 65
L-4 - FSL .....	66 – 69
Spring Retained - FSS .....	70 – 73

**Catch-All™ Safety Screens** ..... 42 – 45**Boss Mount Strainers** ..... 55 – 57**HI-BAR® Safety Screens**

Flange Mounted - FSHF .....	74 – 85
Boss Mounted - FSHB .....	86 – 107
Boss Access - BAS .....	108 – 113
Ring Locked and Straight Thread Adapters – FSI .....	114 – 138

**Special Products** ..... 139

## A RELATIVE RATING SYSTEM FOR SAFETY SCREENS

*Reprinted in part from 2 articles published in Machine Design, submitted by R. Kolp, Vice President, Research and Development, The Lee Company.*

### THE PROBLEM

The need to protect orifices, relief valves, and other sensitive hydraulic components from contamination is widely recognized, but contaminant size has a lot to do with the type of protection needed. Critical components are often relatively immune to low levels of small-size contaminants, but a single large particle can cause sudden failure - possibly with catastrophic effects. While filters maintain fluid cleanliness during operation, large particles, which are built into the system or introduced later, require a different approach. Here, safety screens provide an added level of protection.

Unfortunately, there are no standard methods to compare the performance of one safety screen to another. This is in contrast to the well-established design and selection methods available for rating filter performance, including beta ratings and bubble point testing. As a result, hydraulic system designers often must resort to costly testing programs or haphazard trial and error methods to select the proper screen.

### THE SOLUTION

To bridge this technology gap, a "resistance to blockage" factor has been developed to explain screen design. This factor relates, without complex analysis or elaborate testing, the roles that the size and number of holes in a screen play in overall performance.

For example, deciding whether a screen with 2000 holes, 0.008" in diameter will last longer than one with 1000, 0.015" holes can cause a lot of headaches. To answer such questions, the Resistance to Blockage (ROB) factor was developed.

The blockage factor is calculated from a volume of fluid with known contamination required to block a screen. Because most safety screens have holes  $\geq 0.004''$  (100  $\mu$ ), contamination specifications such as NAS 1638 and ISO 4406 are of no use (the largest particles they deal with are 100  $\mu$ ). Thus MIL-STD 1246, which deals with large particle contamination, was chosen as the baseline for comparison. Using MIL-STD 1246 Class 200 fluid, the blockage factor is defined.

$$ROB = \frac{N}{63.25 n}$$

where  $n = 10^{(4.9029 - 0.926 \log^2 d)}$

and  $d$  = hole size,  $\mu$ , and  $N$  = number of holes in a screen.

A master screen with  $ROB = 1$  is defined as having 1000 holes all 100  $\mu$  in size. Taking a ratio of any other screen to the master gives a comparison of the Resistance to Blockage.

Because a ratio is involved, a lot of errors cancel. Factors such as the flow rate and mode of clogging may be unknown, but both screens are affected in the same relative manner. For example, if comparing two screens and the fluid is cleaner than Class 200, both will last longer than with Class 200 fluid, but they will still clog at the same ratio. About the only data needed are the size and number of holes.

In all systems, the more known about the fluid environment, the more accurate a design can be. However, lacking detailed knowledge of a system, the  $ROB$  factor is a lot better than guessing because it offers a ranking system independent of many system variables.

ROB numbers provide a reliable means of comparing one screen design to others. The following table gives a single orifice ROB number based simply on the diameter of the hole. When multiplied by the number of holes in a screen, the screen ROB number is obtained.

$$\text{Screen ROB \#} = \text{Single orifice ROB \#} \times \# \text{ of holes.}$$

The screen ROB number is an indication of the relative resistance to blockage of the screen, independent of the type of contamination or the flow rate. A higher number indicates a more blockage resistant screen.

Using the preceding example, it can be seen how easily the ROB number table (page 6) or graph (page 7) allows comparison of various screens.

Example: Which screen will be more resistant to blockage? A screen with 2000, 0.008" diameter holes or a screen with 1000, 0.015" diameter holes?

Solution: From the table look up an 0.008" diameter hole. Its ROB number is 0.0169. Multiplying by 2000 yields the screen ROB number of 34.

Referring to the table again, for a 0.015" diameter hole the single orifice ROB number is found to be 0.291. Again multiplying by the number of holes (1000) gives the screen ROB number of 291. Therefore, in this case, the screen with fewer, larger diameter holes has a higher resistance to blockage.

Alternatively, the Safety Screen Numbers graph on page 7 may be used. Simply locate the intersection of the number of holes and hole size to determine the ROB number.

**TABLE OF SINGLE ORIFICE RO<sub>B</sub> NUMBERS  
FOR SAFETY SCREEN ANALYSIS**

Hole Size		Single Orifice RO <sub>B</sub> Number
Inch	Micron	
0.002	51	0.0000979
0.003	76	0.000376
0.004	102	0.00106
0.005	127	0.00248
0.006	152	0.00511
0.007	178	0.00963
0.008	203	0.0169
0.009	229	0.0281
0.010	254	0.0448
0.011	279	0.0687
0.012	305	0.1023
0.013	330	0.1482
0.014	356	0.210
0.015	381	0.291
0.016	406	0.397
0.020	508	1.19

See Engineering Section, **pages O56 – O57** for complete RO<sub>B</sub> Number Table.

## SAFETY SCREEN $RO_B$ NUMBERS

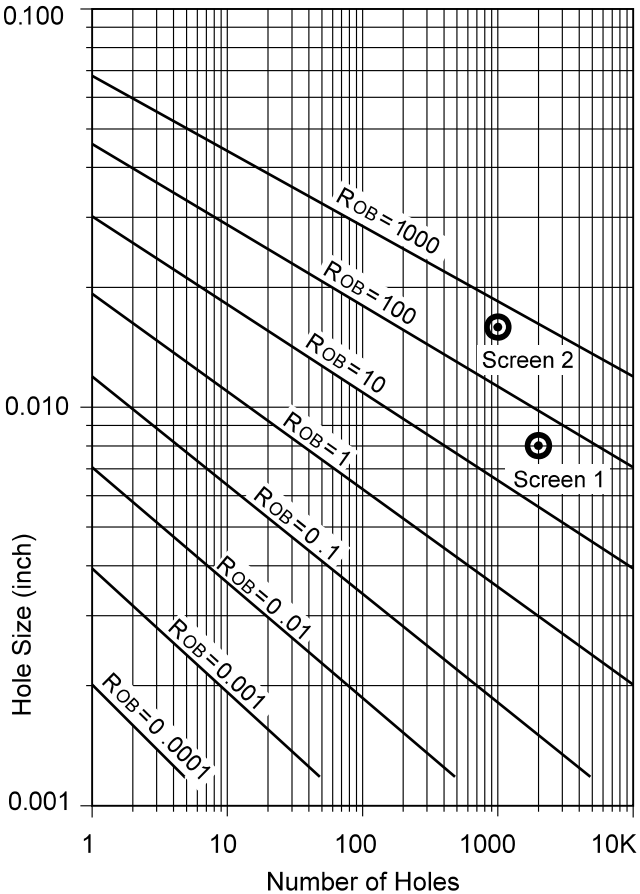

## FILTERS vs. SAFETY SCREENS

All hydraulic systems contain some contamination, and large particles are possibly present at start-up or will be introduced during its lifetime. The particles can be machining chips, Teflon® tape, weld flash, O-ring chips, wear particles, and debris from failing components. These particles enter the system through various means, including:

- Built into new or recently overhauled components.
- During introduction of make-up fluid.
- Making or breaking line connections.
- Component failure.

Often, large particle contamination is the result of something as innocuous as a mechanic snagging a piece of paper towel inside a pipe while cleaning the system.

Filters come in a wide variety of types, sizes, and capacities, and they address a wide ranging size of particle contamination. Typically, filters collect particles less than 100  $\mu$  in size. Most often, a single filter is used, but some systems have several located throughout the circuit. In most cases, the fluid contaminants being filtered have circulated through the various hydraulic components.

Unfortunately, in aircraft, machine tools, and other large systems, sensitive components such as check valves, restrictors, and relief valves are often located far from the system filter. Thus, they have little protection from large contaminants. Further, the components are often in hard to reach locations, and failure results in extensive and costly downtime. Large particles can cause component failure by blocking a flow restrictor or holding open a check valve. Safety screens, either integral to the individual component or located immediately upstream, provide an added margin of safety.

**CLOGGING**

As a safety screen accumulates particles, the pressure drop will slowly increase until the screen is almost fully clogged. Then the pressure drop increases dramatically. For example, consider a clean safety screen in a 3000 psi hydraulic system. At its normal flow rate the screen pressure drop is 6 psi. That same screen will see a pressure drop of only 150 psi when 80% clogged. However, at 95% clogged, the differential pressure jumps to 2500 psi. This phenomenon is represented by the following formula:

$$\Delta P = \frac{\Delta P_0}{(1 - \% \text{ clogged})^2}$$

Where  $\Delta P_0$  is the pressure drop across the screen when it is clean

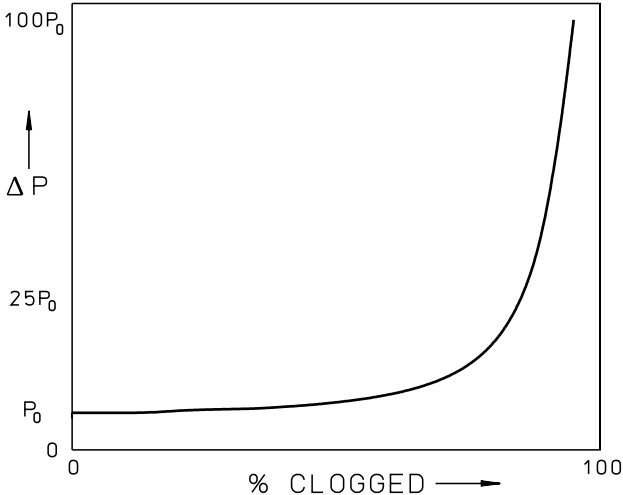

This rapid build up of pressure can be withstood by Lee HI-BAR® Screens which should be specified whenever clogging can induce a high differential pressure.

## LOCATION

The location of a safety screen within a system is a very important design consideration. The safety screen should be located as close as possible to the critical component it is to protect. This will allow all of the flow entering this component, and only that flow, to be filtered by the safety screen. Safety screens are limited in their filtering capacity and therefore, every effort must be made by the designer to ensure that only the flow entering the critical component will pass through the safety screen. If the flow through a critical component is bidirectional then a safety screen should be located at each inlet. This design practice is followed with all Lee restrictors and valves where safety screen protection is required.

Common Nomenclature:

1st Tier Screen	Main System Filter
2nd Tier Screen	Located in critical flow parts i.e., actuator inlet screens
3rd Tier Screen	Located directly on critical components

## PRESSURE RATINGS

The burst or collapse pressure rating of a safety screen is a critical but sometimes overlooked safety screen design consideration. The Lee Company defines burst as a rupture in the outward direction, while collapse is deformation in the inward direction. If a safety screen becomes partially or fully clogged, and it is not strong enough to withstand the differential pressure, the results of this failure could become catastrophic. When a safety screen ruptures, a sudden, heavy concentration of dirt flushes downstream, possibly with fragments of the screen itself, most likely disabling sensitive

downstream components. This is a “hard” failure as opposed to a “soft” failure in which the flow through a Lee HI-BAR® safety screen is gradually reduced (possibly leading to zero flow). A contamination induced malfunction caused by a ruptured safety screen is also unpredictable and can occur without warning since safety screens are not equipped with  $\Delta P$  indicators or bypass relief valves.

However infrequent, safety screen failure does happen and therefore The Lee Company recommends at minimum, that the burst or collapse pressure rating of a second tier safety screen equal full system pressure. Selecting a safety screen with a burst and collapse pressure greater than system pressure is conservative design practice. The military specification MIL-H-5440H, “Hydraulic Systems, Aircraft, Design and Installation Requirements For” makes the following recommendation for second tier screens (Paragraph 3.11.13.1): “It is recommended that second tier screens, as defined by AIR4057 should, when fully clogged, withstand a proof pressure test without collapse, rupture, or permanent deformation.” Many of today’s military and commercial aircraft manufacturers are even specifying second tier safety screen burst and collapse pressure requirements equal to the proof pressure of the system. The Lee Company’s HI-BAR® safety screen product line is designed to meet these requirements with the rated burst and collapse pressures up to 7500 psid in both flow directions!

Third tier screens (mounted directly on components) typically have lower burst and collapse ratings.

## HOLE SIZES

The safety screen hole size should be based on the minimum passage size, such as a valve opening or clearance, or orifice diameter. Typically, the safety screen hole size is chosen to equal 30 to 70 percent of the minimum passage size. For example, a 0.012" diameter orifice might be protected with a safety screen having 0.004" or 0.008" holes, used downstream of a system filter with a 15  $\mu\text{m}$  rating. It is good design practice to make certain that the smallest passageways of critical components are always maximized. The Lee Company offers a full range of restrictors and valves with optimized clearances that are presented in the Lee Technical Hydraulic Handbook. Lee multi-orifice restrictors, such as the Lee Visco Jet<sup>®</sup>, provide a high level of restriction to fluid flow using a tortuous flow path and large minimum passage sizes. Lee Visco Jet<sup>®</sup> minimum passage sizes range from 0.005" to 0.062" as compared to 0.0015" to 0.026", respectively, for the equivalent single orifice restriction, greatly reducing contamination sensitivity.

The hole size of the safety screen should also be chosen to be larger than any upstream filter, to prevent clogging by fine particles normally removed by these filters. There may often be three or more levels of filtration or "tiers" that fluid must flow through before reaching a critical component. For example, in a typical hydraulic system, the system fluid will first flow through a main system filter (first tier) then branch off to a control valve which has an inlet safety screen (second tier). The holes sizes of each subsequent tier should be coarser than the previous one to prevent the accumulation of contamination at any one level.

## STANDARD LEE HOLE SIZES

The Lee Company offers a wide range of hole sizes in a variety of standard safety screens including:

- Lee Etched Screens: 0.003", 0.004", 0.006", 0.008", 0.010", 0.015" and 0.020"
- Lee HI-BAR® Screens: 0.002", 0.003", 0.004", 0.006", 0.008", 0.010", 0.015" and 0.020"
- Lee Boss Mount Strainers: 0.038" and 0.062"
- Lee Catch-All Safety Screens: 0.0008" (20 micron)

Hole Sizes as small as 0.001" and as large as 0.060" are also possible for special HI-BAR Screen applications.

## OPEN AREA

The term "open area" is a useful measure of contamination holding capacity. When comparing screens of similar hole sizes, open area gives a quick indication of the dirt holding capacity of one design versus another. It is simply the product of the number of holes times the area of a nominal hole. The ratio of open area to total area is called "percent open area." A high percent open area indicates a potentially weaker screen design that is less able to withstand high differential pressures.

When a Safety Screen is used to protect an orifice, the open area of the screen is compared to the open area of the orifice. By taking a simple ratio of the screen open area to the orifice area one can gauge the potential pressure drop across the screen relative to the orifice.

Open area should only be used when comparing screens of similar hole size and shape. To compare screens with different hole sizes, ROB numbers should be used. For example: If two screens have the same open area, one screen with 0.004" holes and the other with 0.008" holes, the screen with the larger holes will have 3.9 times the resistance to blockage as the smaller hole screen!

## COLD START

The flow capacity of a Safety Screen during cold-start must also be considered. A cold-start refers to the unusually high pressure drop that occurs through all components including safety screens when a system is first started up and the fluid is cold and viscous. The system designer should realize that due to the effects of viscosity, a Safety Screen during cold-start may have a pressure drop many times greater than operation at normal temperatures. Therefore, a maximum allowable pressure drop across the Safety Screen at the rated flow for this condition must be specified.

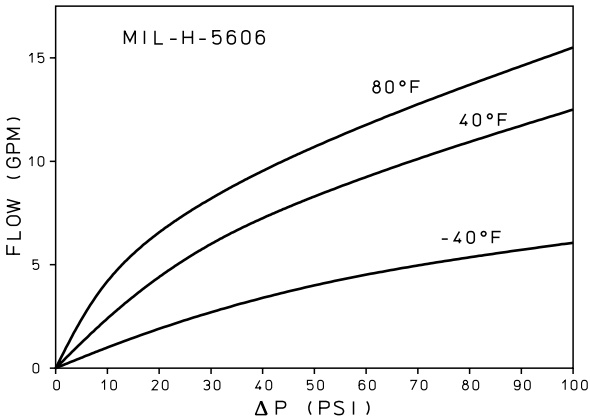

Typical performance of a 20 Lohm Safety Screen.

**CONSTRUCTION METHODS FOR ETCHED SCREENS, CATCH-ALL SCREENS, AND BOSS MOUNT STRAINERS**

Lee Etched Safety Screens are constructed from photochemically etched stainless steel stock that is formed and brazed to a base washer (flange) or insert locking end.

Etched Safety Screens can be formed in two ways; “radial pleated” and “circular pleated.” Radial pleated screens are found on the etched flange and boss mount safety screens, and screened inserts. Circular pleated screens are a patented method of increasing screen open area for a given size and are used on the etched flange, boss mount, TWIS and L-4 safety screens.

All standard Lee Etched Screens are made from 304L or 17-7PH stainless steel stock. Discs with the etched hole pattern are formed into cups with convoluted sides, to provide the optimum amount of protection with the least possible volume. With strict attention to cleanliness throughout the process, these cups are then brazed without flux to a base washer in a reducing atmosphere of dry hydrogen. Rigorous process control and regular microstructural examinations ensure the integrity of Lee Etched Safety Screens. The silver or gold braze material used conforms with the SAE Aerospace Material Specification 4774 or 4786. Its major characteristics are as follows:

<b>SILVER BRAZE / AMS 4774</b>	
<b>COMPOSITION</b>	<b>NOMINAL VALUES</b>
Silver	63.0%
Copper	28.5%
Tin	6.0%
Nickel	2.5%
<b>RECOMMENDATIONS</b>	<b>MAXIMUM TEMPERATURE</b>
Short Term Service	700°F (371°C)
Long Term Service	400°F (204°C)

## **CONSTRUCTION METHODS FOR ETCHED SCREENS, CATCH-ALL SCREENS, AND BOSS MOUNT STRAINERS, cont.**

<b>GOLD BRAZE / AMS 4786</b>	
<b>COMPOSITION</b>	<b>NOMINAL VALUES</b>
Gold	70%
Palladium	8%
Nickel	22%

Lee Boss Mount Strainers and Lee Catch-All Safety Screens use construction methods that are similar to etched screens. While the Boss Mount Strainers use the same 304L CRES and silver braze per AMS 4774, the Catch-All Screens use 316 CRES and silver braze per AMS 4765.

<b>SILVER BRAZE / AMS 4765</b>	
<b>COMPOSITION</b>	<b>NOMINAL VALUES</b>
Silver	56%
Copper	42%
Nickel	2%

## **CONSTRUCTION METHODS FOR DRILLED SCREENS**

Lee Drilled Safety Screens are machined from solid bar stock, typically 15-5 precipitation hardening stainless steel for its high strength capabilities. HI-BAR® Screens are also available in other standard materials including brass, MP35N, PEEK, and Titanium. Alternate materials such as 300 series stainless steels, aluminum, and nickel based alloys may be used for special applications. Individually drilled and deburred by proprietary manufacturing processes, these Safety Screens feature an extremely robust, one-piece design without joints or seams.

<b>TYPICAL MATERIALS</b>		
<b>MATERIAL</b>	<b>HEAT TREAT</b>	<b>MAXIMUM SERVICE TEMP.</b>
15-5PH Cres	H1025	900°F (482°C)
303 Cres	N/A	400°F (204°C)
2024 Alum	T651	300°F (149°C)

## **PRECISION CLEANING OF LEE SAFETY SCREENS**

Contamination control is a necessity in today's high performance fluid systems. As safety screens are meant to improve system performance by providing additional protection beyond the system filter, special precautions need to be taken to ensure that the screens themselves are not a source of built-in contamination. While The Lee Company has always manufactured our components in a clean work environment, we have added an additional safeguard by implementing Lee Process Specification H1025 (PS H1025), *Precision Cleaning and Packaging of Lee Safety Screens*. This specification outlines the procedures and controls for a final cleaning step just prior to packaging. It also specifies standard and cleanroom packaging requirements for Lee Safety Screens, and is available upon request.

**FLANGE MOUNTED**

This is perhaps the most common installation technique as it is simple and economical.

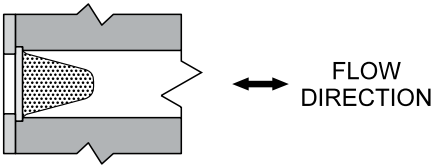
**BOSS MOUNTED**

A common installation technique that permits removal. Some form of anti-rotation locking is recommended.

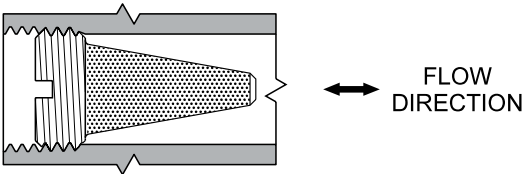

## INSERT RETAINED

Utilizing the proven *Lee Insert Principle*, this technique is ideal for simple installation directly into a fluid passageway.

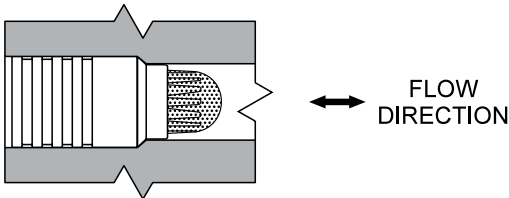

## L-4

Featuring three locking fingers that are expanded outward locking the screen in a fluid passageway, the L-4 technique permits easy removal for inspection or cleaning. Ideal for bidirectional flow.

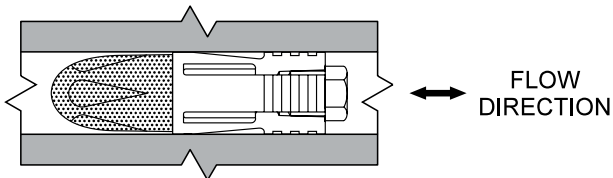

**SPRING RETAINED**

An inexpensive mounting technique suitable for uni-directional flow. The spring O.D. is slightly larger than the I.D. of the mounting hole. A special tool is used to twist the spring into the hole.

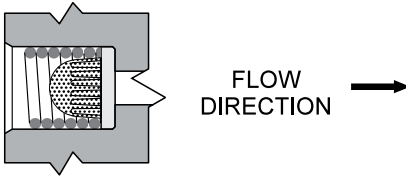
**TWIS<sup>®</sup>**

Easily removable, the "TWIS" style of installation is readily twisted in or out of the bore for inspection or cleaning. Unidirectional flow.

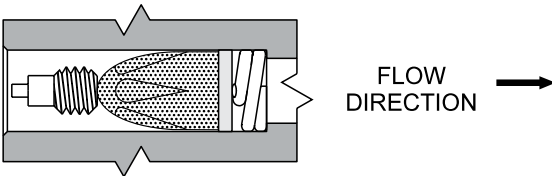

## BOSS ACCESS

A convenient mounting technique that permits easy removal for cleaning or inspection.

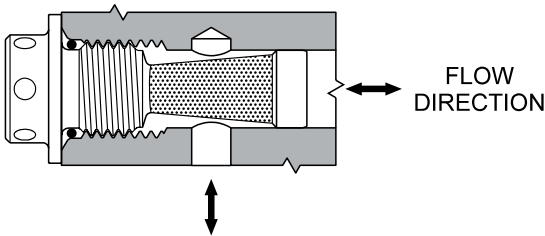

## HI-BAR® SCREENS IN ADAPTERS

Often used as inlet screens to actuators, optimizing space and weight. Available in AS-straight thread and Ring Locked style adapters complete from The Lee Company.

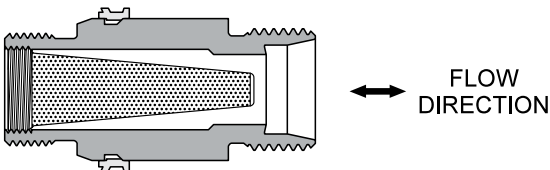



## **ETCHED SAFETY SCREENS**

**Flange Mounted**

**Boss Mounted**

**Insert Retained**

**L-4**

**Spring Retained**

**TWIS**

## **CATCH-ALL™ SAFETY SCREENS**

## **BOSS MOUNT STRAINERS**

FSJA GROUP



## **FLANGE MOUNTED SAFETY SCREENS**

- ❑ **Simple, economical flange mounted design**
- ❑ **98 standard versions for design flexibility**
- ❑ **Maximum open screen area**
- ❑ **All stainless steel construction**
- ❑ **Hole sizes from 0.0008" to 0.020"**

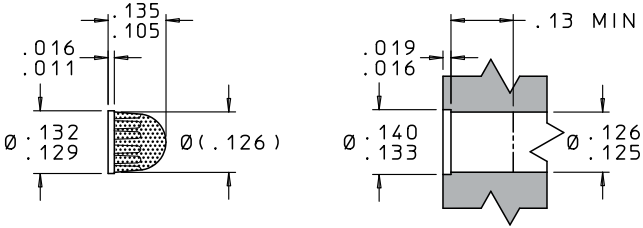

### PERFORMANCE

LEE PART NUMBER	LOHM RATE (nom.)	BURST PRESSURE psid (min.)	COLLAPSE PRESSURE psid (min.)	Rob NUMBER
FSJA1300030A	250	1500	450	0.7
FSJA1300040A	250	1800	750	1.6
FSJA1300060A	250	2400	1100	3.6
FSJA1300080A	250	3000	3000	4.2
FSJA1300100A	250	3000	2500	11
FSJA1300150A	250	3000	2200	44
FSJA1300200A	250	3000	2200	89

### SPECIFICATIONS (nom.)

LEE PART NUMBER	HOLE SIZE in	HOLE SIZE $\mu\text{m}$	OPEN AREA in <sup>2</sup>	TOTAL AREA in <sup>2</sup>	NUMBER OF HOLES
FSJA1300030A	0.003	75	0.014	0.062	1980
FSJA1300040A	0.004	100	0.019	0.062	1500
FSJA1300060A	0.006	150	0.020	0.062	700
FSJA1300080A	0.008	200	0.014	0.062	250
FSJA1300100A	0.010	250	0.019	0.062	240
FSJA1300150A	0.015	380	0.026	0.062	150
FSJA1300200A	0.020	500	0.024	0.062	80

### MATERIALS

PART	MATERIAL	SPECIFICATION
Screen	304L CRES	ASTM A 666
Base Washer	304L CRES	ASTM A 666
Braze	Silver Alloy	AMS 4774

Finish: All Cres Parts Passivated.

# 130 Flange Mount: 17-7PH Safety Screen 27

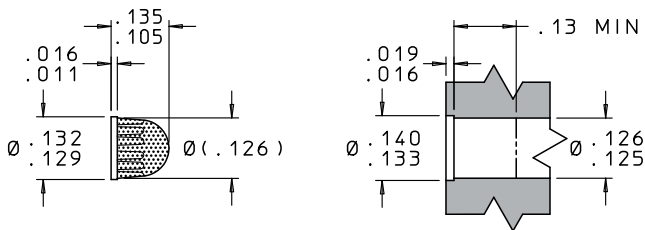

PERFORMANCE				
LEE PART NUMBER	LOHM RATE (nom.)	BURST PRESSURE psid (min.)	COLLAPSE PRESSURE psid (min.)	Rob NUMBER
FSJA1300047A	250	3750	1350	1.6
FSJA1300067A	250	4600	3500	3.6
FSJA1300087A	250	7100	3500	4.2
FSJA1300107A	250	5500	3200	11
FSJA1300157A	250	7000	4550	44
FSJA1300207A	250	5000	3200	89

SPECIFICATIONS (nom.)					
LEE PART NUMBER	HOLE SIZE in	HOLE SIZE $\mu\text{m}$	OPEN AREA in <sup>2</sup>	TOTAL AREA in <sup>2</sup>	NUMBER OF HOLES
FSJA1300047A	0.004	100	0.019	0.062	1500
FSJA1300067A	0.006	150	0.020	0.062	700
FSJA1300087A	0.008	200	0.014	0.062	250
FSJA1300107A	0.010	250	0.019	0.062	240
FSJA1300157A	0.015	380	0.026	0.062	150
FSJA1300207A	0.020	500	0.024	0.062	80

MATERIALS		
PART	MATERIAL	SPECIFICATION
Screen	17-7PH CRES	AMS 5529
Base Washer	17-7PH CRES	AMS 5529 or AMS 5644
Braze	Gold Alloy	AMS 4786

Finish: All Cres Parts Passivated.

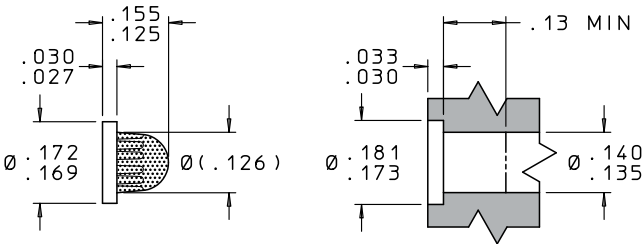

### PERFORMANCE

LEE PART NUMBER	LOHM RATE (nom.)	BURST PRESSURE psid (min.)	COLLAPSE PRESSURE psid (min.)	Rob NUMBER
FSJA1700030A	250	1500	450	0.7
FSJA1700040A	250	1800	750	1.6
FSJA1700060A	250	2400	1100	3.6
FSJA1700080A	250	3000	3000	4.2
FSJA1700100A	250	3000	2500	11
FSJA1700150A	250	3000	2200	44
FSJA1700200A	250	3000	2200	89

### SPECIFICATIONS (nom.)

LEE PART NUMBER	HOLE SIZE in	HOLE SIZE $\mu\text{m}$	OPEN AREA in <sup>2</sup>	TOTAL AREA in <sup>2</sup>	NUMBER OF HOLES
FSJA1700030A	0.003	75	0.014	0.062	1980
FSJA1700040A	0.004	100	0.019	0.062	1500
FSJA1700060A	0.006	150	0.020	0.062	700
FSJA1700080A	0.008	200	0.014	0.062	250
FSJA1700100A	0.010	250	0.019	0.062	240
FSJA1700150A	0.015	380	0.026	0.062	150
FSJA1700200A	0.020	500	0.024	0.062	80

### MATERIALS

PART	MATERIAL	SPECIFICATION
Screen	304L CRES	ASTM A 666
Base Washer	304L CRES	ASTM A 666
Braze	Silver Alloy	AMS 4774

Finish: All Cres Parts Passivated.

# 170 Flange Mount: 17-7PH Safety Screen 29

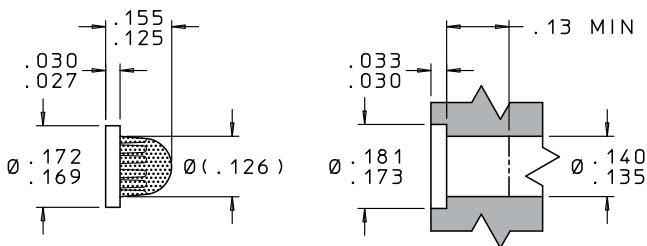

PERFORMANCE				
LEE PART NUMBER	LOHM RATE (nom.)	BURST PRESSURE psid (min.)	COLLAPSE PRESSURE psid (min.)	Rob NUMBER
FSJA1700047A	250	3750	1350	1.6
FSJA1700067A	250	4600	3500	3.6
FSJA1700087A	250	7100	3500	4.2
FSJA1700107A	250	5500	3200	11
FSJA1700157A	250	7000	4550	44
FSJA1700207A	250	5000	3200	89

SPECIFICATIONS (nom.)					
LEE PART NUMBER	HOLE SIZE in	HOLE SIZE $\mu\text{m}$	OPEN AREA in <sup>2</sup>	TOTAL AREA in <sup>2</sup>	NUMBER OF HOLES
FSJA1700047A	0.004	100	0.019	0.062	1500
FSJA1700067A	0.006	150	0.020	0.062	700
FSJA1700087A	0.008	200	0.014	0.062	250
FSJA1700107A	0.010	250	0.019	0.062	240
FSJA1700157A	0.015	380	0.026	0.062	150
FSJA1700207A	0.020	500	0.024	0.062	80

MATERIALS		
PART	MATERIAL	SPECIFICATION
Screen	17-7PH CRES	AMS 5529
Base Washer	17-7PH CRES	AMS 5529 or AMS 5644
Braze	Gold Alloy	AMS 4786

Finish: All Cres Parts Passivated.

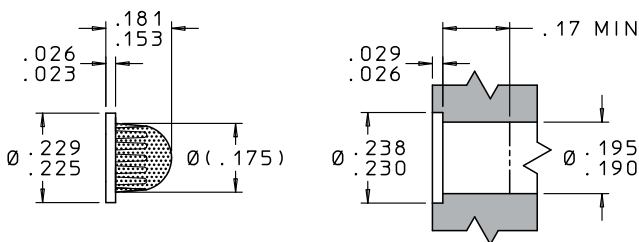
**PERFORMANCE**

LEE PART NUMBER	LOHM RATE (nom.)	BURST PRESSURE psid (min.)	COLLAPSE PRESSURE psid (min.)	Rob NUMBER
FSJA2300030A	95	900	250	1.2
FSJA2300040A	95	900	250	2.5
FSJA2300060A	95	1100	375	5.8
FSJA2300080A	95	1900	1200	8.1
FSJA2300100A	95	1900	1200	17
FSJA2300150A	95	1500	1000	70
FSJA2300200A	95	1500	1000	141

**SPECIFICATIONS (nom.)**

LEE PART NUMBER	HOLE SIZE in	HOLE SIZE $\mu\text{m}$	OPEN AREA in <sup>2</sup>	TOTAL AREA in <sup>2</sup>	NUMBER OF HOLES
FSJA2300030A	0.003	75	0.022	0.098	3100
FSJA2300040A	0.004	100	0.029	0.098	2330
FSJA2300060A	0.006	150	0.032	0.098	1130
FSJA2300080A	0.008	200	0.024	0.098	480
FSJA2300100A	0.010	250	0.030	0.098	390
FSJA2300150A	0.015	380	0.042	0.098	240
FSJA2300200A	0.020	500	0.037	0.098	120

**MATERIALS**

PART	MATERIAL	SPECIFICATION
Screen	304L CRES	ASTM A 666
Base Washer	304L CRES	ASTM A 666
Braze	Silver Alloy	AMS 4774

Finish: All Cres Parts Passivated.

# 230 Flange Mount: 17-7PH Safety Screen

# 31

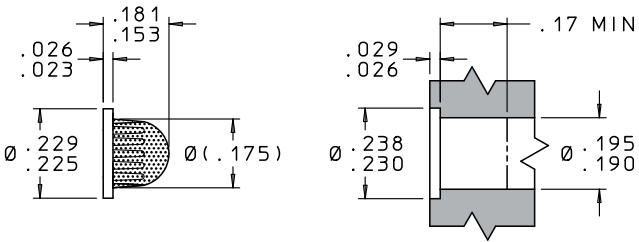

PERFORMANCE				
LEE PART NUMBER	LOHM RATE (nom.)	BURST PRESSURE psid (min.)	COLLAPSE PRESSURE psid (min.)	Rob NUMBER
FSJA2300047A	95	2050	850	2.5
FSJA2300067A	95	3600	1600	5.8
FSJA2300087A	95	3850	1700	8.1
FSJA2300107A	95	3700	1700	17
FSJA2300157A	95	3300	1700	70
FSJA2300207A	95	3000	1700	141

SPECIFICATIONS (nom.)					
LEE PART NUMBER	HOLE SIZE in	HOLE SIZE $\mu\text{m}$	OPEN AREA in <sup>2</sup>	TOTAL AREA in <sup>2</sup>	NUMBER OF HOLES
FSJA2300047A	0.004	100	0.029	0.098	2330
FSJA2300067A	0.006	150	0.032	0.098	1130
FSJA2300087A	0.008	200	0.024	0.098	480
FSJA2300107A	0.010	250	0.030	0.098	390
FSJA2300157A	0.015	380	0.042	0.098	240
FSJA2300207A	0.020	500	0.037	0.098	120

MATERIALS		
PART	MATERIAL	SPECIFICATION
Screen	17-7PH CRES	AMS 5529
Base Washer	17-7PH CRES	AMS 5529 or AMS 5644
Braze	Gold Alloy	AMS 4786

Finish: All Cres Parts Passivated.

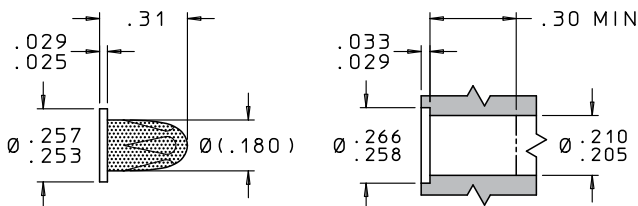

## PERFORMANCE

LEE PART NUMBER	LOHM RATE (nom.)	BURST PRESSURE psid (min.)	COLLAPSE PRESSURE psid (min.)	Rob NUMBER
FSJA2550030A	85	800	150	2.7
FSJA2550040A	85	800	200	5.4
FSJA2550060A	85	1800	550	11
FSJA2550080A	85	1200	450	21
FSJA2550100A	85	1200	450	39
FSJA2550150A	85	1200	400	131
FSJA2550200A	85	1200	300	317

## SPECIFICATIONS (nom.)

LEE PART NUMBER	HOLE SIZE in	HOLE SIZE $\mu\text{m}$	OPEN AREA in <sup>2</sup>	TOTAL AREA in <sup>2</sup>	NUMBER OF HOLES
FSJA2550030A	0.003	75	0.05	0.22	7050
FSJA2550040A	0.004	100	0.06	0.22	5100
FSJA2550060A	0.006	150	0.06	0.22	2250
FSJA2550080A	0.008	200	0.06	0.22	1250
FSJA2550100A	0.010	250	0.07	0.22	870
FSJA2550150A	0.015	380	0.08	0.22	450
FSJA2550200A	0.020	500	0.08	0.22	270

## MATERIALS

PART	MATERIAL	SPECIFICATION
Screen	304L CRES	ASTM A 666
Base Washer	304L CRES	ASTM A 666
Braze	Silver Alloy	AMS 4774

Finish: All Cres Parts Passivated.

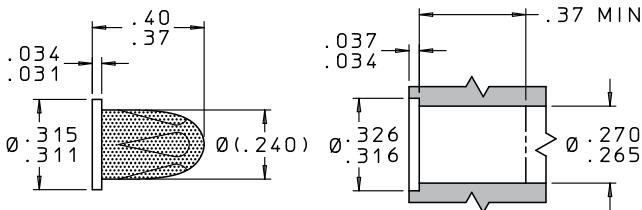

PERFORMANCE				
LEE PART NUMBER	LOHM RATE (nom.)	BURST PRESSURE psid (min.)	COLLAPSE PRESSURE psid (min.)	RoB NUMBER
FSJA3120030A	40	450	100	4.3
FSJA3120040A	40	450	150	9.5
FSJA3120060A	40	550	150	20
FSJA3120080A	40	900	200	34
FSJA3120100A	40	900	200	65
FSJA3120150A	40	900	175	247
FSJA3120200A	40	900	175	533

SPECIFICATIONS (nom.)					
LEE PART NUMBER	HOLE SIZE in	HOLE SIZE $\mu\text{m}$	OPEN AREA in <sup>2</sup>	TOTAL AREA in <sup>2</sup>	NUMBER OF HOLES
FSJA3120030A	0.003	75	0.08	0.37	11 300
FSJA3120040A	0.004	100	0.11	0.37	9 000
FSJA3120060A	0.006	150	0.11	0.37	4 000
FSJA3120080A	0.008	200	0.10	0.37	2 000
FSJA3120100A	0.010	250	0.11	0.37	1 460
FSJA3120150A	0.015	380	0.15	0.37	850
FSJA3120200A	0.020	500	0.14	0.37	450

MATERIALS		
PART	MATERIAL	SPECIFICATION
Screen	304L CRES	ASTM A 666
Base Washer	304L CRES	ASTM A 666
Braze	Silver Alloy	AMS 4774

Finish: All Cres Parts Passivated.

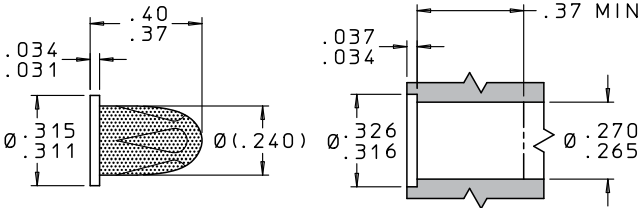

PERFORMANCE				
LEE PART NUMBER	LOHM RATE (nom.)	BURST PRESSURE psid (min.)	COLLAPSE PRESSURE psid (min.)	Rob NUMBER
FSJA3120047A	40	1250	250	9.5
FSJA3120067A	40	2600	550	20
FSJA3120087A	40	3150	800	34
FSJA3120107A	40	2900	600	65
FSJA3120157A	40	2750	800	247
FSJA3120207A	40	2200	550	533

SPECIFICATIONS (nom.)					
LEE PART NUMBER	HOLE SIZE in	HOLE SIZE $\mu\text{m}$	OPEN AREA in <sup>2</sup>	TOTAL AREA in <sup>2</sup>	NUMBER OF HOLES
FSJA3120047A	0.004	100	0.11	0.37	9000
FSJA3120067A	0.006	150	0.11	0.37	4000
FSJA3120087A	0.008	200	0.10	0.37	2000
FSJA3120107A	0.010	250	0.11	0.37	1460
FSJA3120157A	0.015	380	0.15	0.37	850
FSJA3120207A	0.020	500	0.14	0.37	450

MATERIALS		
PART	MATERIAL	SPECIFICATION
Screen	17-7PH CRES	AMS 5529
Base Washer	17-7PH CRES	AMS 5529 or AMS 5644
Braze	Gold Alloy	AMS 4786

Finish: All Cres Parts Passivated.

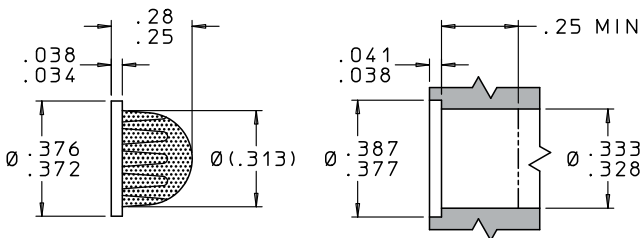

PERFORMANCE				
LEE PART NUMBER	LOHM RATE (nom.)	BURST PRESSURE psid (min.)	COLLAPSE PRESSURE psid (min.)	Rob NUMBER
FSJA3750030A	20	400	100	3.7
FSJA3750040A	20	400	100	8.0
FSJA3750060A	20	800	275	18
FSJA3750080A	20	1000	500	30
FSJA3750100A	20	1000	500	53
FSJA3750150A	20	800	275	180
FSJA3750200A	20	800	275	432

SPECIFICATIONS (nom.)					
LEE PART NUMBER	HOLE SIZE in	HOLE SIZE $\mu\text{m}$	OPEN AREA in <sup>2</sup>	TOTAL AREA in <sup>2</sup>	NUMBER OF HOLES
FSJA3750030A	0.003	75	0.07	0.30	9900
FSJA3750040A	0.004	100	0.09	0.30	7500
FSJA3750060A	0.006	150	0.10	0.30	3500
FSJA3750080A	0.008	200	0.09	0.30	1800
FSJA3750100A	0.010	250	0.09	0.30	1180
FSJA3750150A	0.015	380	0.11	0.30	620
FSJA3750200A	0.020	500	0.11	0.30	360

MATERIALS		
PART	MATERIAL	SPECIFICATION
Screen	304L CRES	ASTM A 666
Base Washer	304L CRES	ASTM A 666
Braze	Silver Alloy	AMS 4774

Finish: All Cres Parts Passivated.

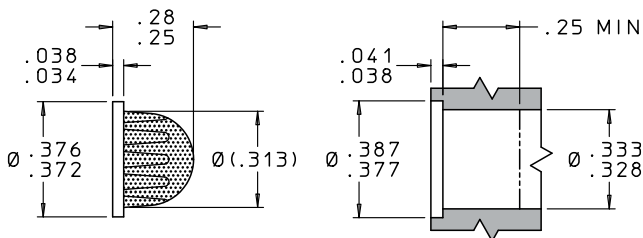

PERFORMANCE				
LEE PART NUMBER	LOHM RATE (nom.)	BURST PRESSURE psid (min.)	COLLAPSE PRESSURE psid (min.)	Rob NUMBER
FSJA3750047A	20	1150	250	8
FSJA3750067A	20	2050	850	18
FSJA3750087A	20	2300	950	30
FSJA3750107A	20	2100	900	53
FSJA3750157A	20	2050	950	180
FSJA3750207A	20	1600	850	432

SPECIFICATIONS (nom.)					
LEE PART NUMBER	HOLE SIZE in	HOLE SIZE $\mu\text{m}$	OPEN AREA in <sup>2</sup>	TOTAL AREA in <sup>2</sup>	NUMBER OF HOLES
FSJA3750047A	0.004	100	0.09	0.30	7500
FSJA3750067A	0.006	150	0.10	0.30	3500
FSJA3750087A	0.008	200	0.09	0.30	1800
FSJA3750107A	0.010	250	0.09	0.30	1180
FSJA3750157A	0.015	380	0.11	0.30	620
FSJA3750207A	0.020	500	0.11	0.30	360

MATERIALS		
PART	MATERIAL	SPECIFICATION
Screen	17-7PH CRES	AMS 5529
Base Washer	17-7PH CRES	AMS 5529 or AMS 5644
Braze	Gold Alloy	AMS 4786

Finish: All Cres Parts Passivated.

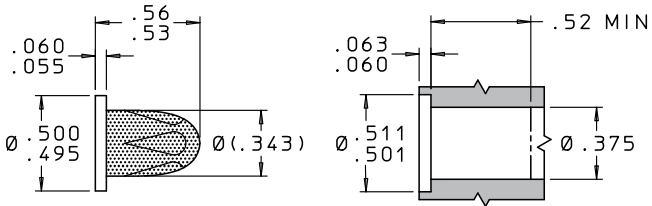

PERFORMANCE				
LEE PART NUMBER	LOHM RATE (nom.)	BURST PRESSURE psid (min.)	COLLAPSE PRESSURE psid (min.)	RoB NUMBER
FSJA5000030A	18	450	50	9.6
FSJA5000040A	18	700	65	19
FSJA5000060A	18	1300	200	45
FSJA5000080A	18	1500	300	64
FSJA5000100A	18	1500	300	138
FSJA5000150A	18	1500	300	527
FSJA5000200A	18	1500	300	1123

SPECIFICATIONS (nom.)					
LEE PART NUMBER	HOLE SIZE in	HOLE SIZE $\mu\text{m}$	OPEN AREA in <sup>2</sup>	TOTAL AREA in <sup>2</sup>	NUMBER OF HOLES
FSJA5000030A	0.003	75	0.18	0.78	25 450
FSJA5000040A	0.004	100	0.23	0.78	18 300
FSJA5000060A	0.006	150	0.25	0.78	8 840
FSJA5000080A	0.008	200	0.19	0.78	3 800
FSJA5000100A	0.010	250	0.24	0.78	3 080
FSJA5000150A	0.015	380	0.32	0.78	1 810
FSJA5000200A	0.020	500	0.30	0.78	940

MATERIALS		
PART	MATERIAL	SPECIFICATION
Screen	304L CRES	ASTM A 666
Base Washer	304L CRES	ASTM A 666
Braze	Silver Alloy	AMS 4774

Finish: All Cres Parts Passivated.

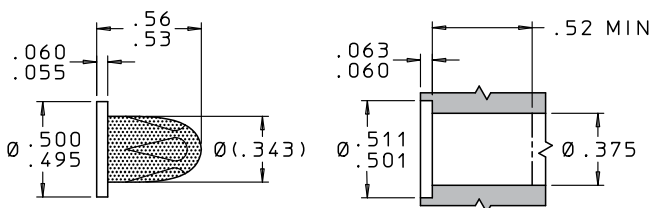

### PERFORMANCE

LEE PART NUMBER	LOHM RATE (nom.)	BURST PRESSURE psid (min.)	COLLAPSE PRESSURE psid (min.)	Rob NUMBER
FSJA5000047A	18	1450	100	19
FSJA5000067A	18	2650	300	45
FSJA5000087A	18	3150	350	64
FSJA5000107A	18	1900	350	138
FSJA5000157A	18	2950	400	527
FSJA5000207A	18	1700	350	1123

### SPECIFICATIONS (nom.)

LEE PART NUMBER	HOLE SIZE in	HOLE SIZE $\mu\text{m}$	OPEN AREA in <sup>2</sup>	TOTAL AREA in <sup>2</sup>	NUMBER OF HOLES
FSJA5000047A	0.004	100	0.23	0.78	18 300
FSJA5000067A	0.006	150	0.25	0.78	8 840
FSJA5000087A	0.008	200	0.19	0.78	3 800
FSJA5000107A	0.010	250	0.24	0.78	3 080
FSJA5000157A	0.015	380	0.32	0.78	1 810
FSJA5000207A	0.020	500	0.30	0.78	940

### MATERIALS

PART	MATERIAL	SPECIFICATION
Screen	17-7PH CRES	AMS 5529
Base Washer	17-7PH CRES	AMS 5529 or AMS 5644
Braze	Gold Alloy	AMS 4786

Finish: All Cres Parts Passivated.

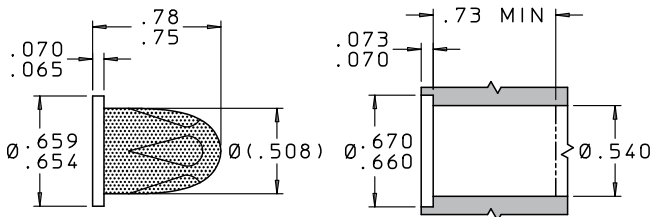

PERFORMANCE				
LEE PART NUMBER	LOHM RATE (nom.)	BURST PRESSURE psid (min.)	COLLAPSE PRESSURE psid (min.)	RoB NUMBER
FSJA6560030A	8.0	250	50	20
FSJA6560040A	8.0	300	50	43
FSJA6560060A	8.0	1000	100	97
FSJA6560080A	8.0	1100	125	138
FSJA6560100A	8.0	1100	100	301
FSJA6560150A	8.0	1100	100	1164
FSJA6560200A	8.0	1000	100	2447

SPECIFICATIONS (nom.)					
LEE PART NUMBER	HOLE SIZE in	HOLE SIZE $\mu\text{m}$	OPEN AREA in <sup>2</sup>	TOTAL AREA in <sup>2</sup>	NUMBER OF HOLES
FSJA6560030A	0.003	75	0.38	1.7	53 750
FSJA6560040A	0.004	100	0.51	1.7	39 630
FSJA6560060A	0.006	150	0.54	1.7	13 700
FSJA6560080A	0.008	200	0.41	1.7	8 600
FSJA6560100A	0.010	250	0.53	1.7	6 710
FSJA6560150A	0.015	380	0.71	1.7	4 000
FSJA6560200A	0.020	500	0.65	1.7	2 060

MATERIALS		
PART	MATERIAL	SPECIFICATION
Screen	304L CRES	ASTM A 666
Base Washer	304L CRES	ASTM A 666
Braze	Silver Alloy	AMS 4774

Finish: All Cres Parts Passivated.

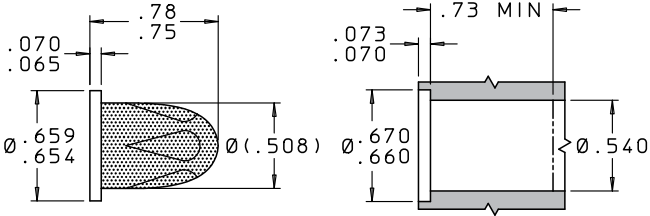

## PERFORMANCE

LEE PART NUMBER	LOHM RATE (nom.)	BURST PRESSURE psid (min.)	COLLAPSE PRESSURE psid (min.)	Rob NUMBER
FSJA6560047A	8.0	1250	100	43
FSJA6560067A	8.0	1750	165	97
FSJA6560087A	8.0	2250	450	138
FSJA6560107A	8.0	1300	250	301
FSJA6560157A	8.0	1750	350	1164
FSJA6560207A	8.0	1200	250	2447

## SPECIFICATIONS (nom.)

LEE PART NUMBER	HOLE SIZE in	HOLE SIZE $\mu\text{m}$	OPEN AREA in <sup>2</sup>	TOTAL AREA in <sup>2</sup>	NUMBER OF HOLES
FSJA6560047A	0.004	100	0.51	1.7	39 630
FSJA6560067A	0.006	150	0.54	1.7	13 700
FSJA6560087A	0.008	200	0.41	1.7	8 600
FSJA6560107A	0.010	250	0.53	1.7	6 710
FSJA6560157A	0.015	380	0.71	1.7	4 000
FSJA6560207A	0.020	500	0.65	1.7	2 060

## MATERIALS

PART	MATERIAL	SPECIFICATION
Screen	17-7PH CRES	AMS 5529
Base Washer	17-7PH CRES	AMS 5529 or AMS 5644
Braze	Gold Alloy	AMS 4786

Finish: All Cres Parts Passivated.

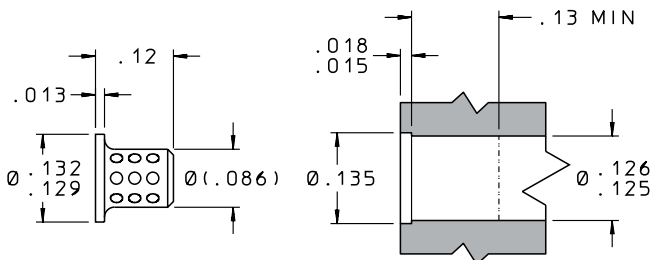

## PERFORMANCE

LEE PART NUMBER	LOHM RATE (nom.)	BURST PRESSURE psid (min.)	COLLAPSE PRESSURE psid (min.)	Rob NUMBER
FSJA1301150A	250	3000	3000	7.9
FSJA1301200A	250	3000	3000	32

## SPECIFICATIONS (nom.)

LEE PART NUMBER	HOLE SIZE in	HOLE SIZE $\mu\text{m}$	OPEN AREA in <sup>2</sup>	TOTAL AREA in <sup>2</sup>	NUMBER OF HOLES
FSJA1301150A	0.015	380	0.005	0.026	27
FSJA1301200A	0.020	510	0.009	0.026	27

## MATERIALS

PART	MATERIAL	SPECIFICATION	FINISH
Screen	303 CRES	QQ-S-763C	Passivated

## 130 FLANGE MOUNT

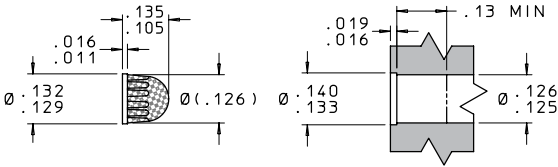

### PERFORMANCE

LEE PART NUMBER	LOHM RATE (nom.)	BURST PRES-SURE psid (min.)	COLLAPSE PRES-SURE psid (min.)	ROB NUMBER
FSFA1300200A	450	2000	1100	0.04

### SPECIFICATIONS (nom.)

LEE PART NUMBER	HOLE SIZE in	HOLE SIZE $\mu\text{m}$	OPEN AREA in <sup>2</sup>	TOTAL AREA in <sup>2</sup>	NUMBER OF HOLES
FSFA1300200A	0.0008	20	0.005	0.062	5000

## 170 FLANGE MOUNT

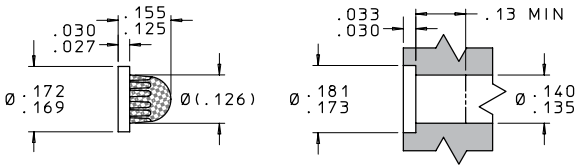

### PERFORMANCE

LEE PART NUMBER	LOHM RATE (nom.)	BURST PRES-SURE psid (min.)	COLLAPSE PRES-SURE psid (min.)	ROB NUMBER
FSFA1700200A	450	2000	1100	0.04

### SPECIFICATIONS (nom.)

LEE PART NUMBER	HOLE SIZE in	HOLE SIZE $\mu\text{m}$	OPEN AREA in <sup>2</sup>	TOTAL AREA in <sup>2</sup>	NUMBER OF HOLES
FSFA1700200A	0.0008	20	0.005	0.062	5000

### MATERIALS

PART	MATERIAL	SPECIFICATION
Screen	316L CRES	ASTM A 478-97
Base Washer	316L CRES	ASTM A 666 or AMS 5653
Braze	Silver Alloy	AMS 4765

Finish: All Cres Parts Passivated.

## 230 FLANGE MOUNT

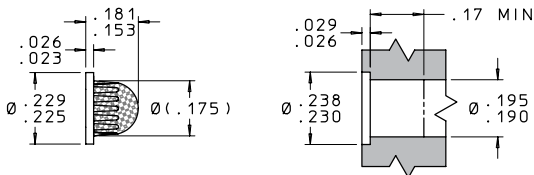

### PERFORMANCE

LEE PART NUMBER	LOHM RATE (nom.)	BURST PRES-SURE psid (min.)	COLLAPSE PRES-SURE psid (min.)	Rob NUMBER
FSFA2300200A	200	1200	600	0.06

### SPECIFICATIONS (nom.)

LEE PART NUMBER	HOLE SIZE in	HOLE SIZE $\mu\text{m}$	OPEN AREA in <sup>2</sup>	TOTAL AREA in <sup>2</sup>	NUMBER OF HOLES
FSFA2300200A	0.0008	20	0.007	0.098	7900

## 255 FLANGE MOUNT

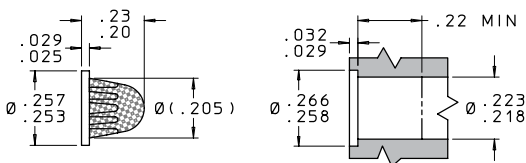

### PERFORMANCE

LEE PART NUMBER	LOHM RATE (nom.)	BURST PRES-SURE psid (min.)	COLLAPSE PRES-SURE psid (min.)	Rob NUMBER
FSFA2550200A	120	1100	400	0.10

### SPECIFICATIONS (nom.)

LEE PART NUMBER	HOLE SIZE in	HOLE SIZE $\mu\text{m}$	OPEN AREA in <sup>2</sup>	TOTAL AREA in <sup>2</sup>	NUMBER OF HOLES
FSFA2550200A	0.0008	20	0.013	0.173	14000

### MATERIALS

PART	MATERIAL	SPECIFICATION
Screen	316L CRES	ASTM A 478-97
Base Washer	316L CRES	ASTM A 666 or AMS 5653
Braze	Silver Alloy	AMS 4765

Finish: All Cres Parts Passivated.

## 312 FLANGE MOUNT

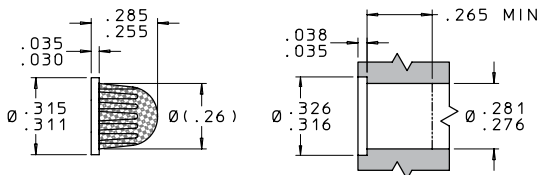

## PERFORMANCE

LEE PART NUMBER	LOHM RATE (nom.)	BURST PRES-SURE psid (min.)	COLLAPSE PRES-SURE psid (min.)	ROB NUMBER
FSFA3120200A	80	1000	350	0.16

## SPECIFICATIONS (nom.)

LEE PART NUMBER	HOLE SIZE in	HOLE SIZE $\mu\text{m}$	OPEN AREA in <sup>2</sup>	TOTAL AREA in <sup>2</sup>	NUMBER OF HOLES
FSFA3120200A	0.0008	20	0.021	0.278	22500

## 375 FLANGE MOUNT

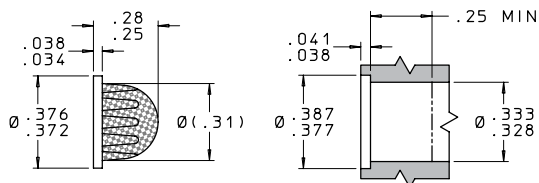

## PERFORMANCE

LEE PART NUMBER	LOHM RATE (nom.)	BURST PRES-SURE psid (min.)	COLLAPSE PRES-SURE psid (min.)	ROB NUMBER
FSFA3750200A	50	700	300	0.18

## SPECIFICATIONS (nom.)

LEE PART NUMBER	HOLE SIZE in	HOLE SIZE $\mu\text{m}$	OPEN AREA in <sup>2</sup>	TOTAL AREA in <sup>2</sup>	NUMBER OF HOLES
FSFA3750200A	0.0008	20	0.023	0.300	24100

## MATERIALS

PART	MATERIAL	SPECIFICATION
Screen	316L CRES	ASTM A 478-97
Base Washer	316L CRES	ASTM A 666 or AMS 5653
Braze	Silver Alloy	AMS 4765

Finish: All Cres Parts Passivated.

## 500 FLANGE MOUNT

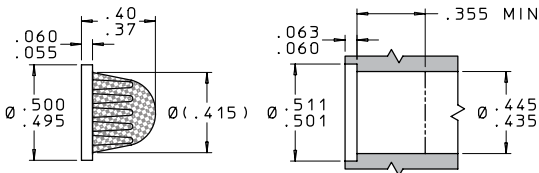

### PERFORMANCE

LEE PART NUMBER	LOHM RATE (nom.)	BURST PRES-SURE psid (min.)	COLLAPSE PRES-SURE psid (min.)	Rob NUMBER
FSFA5000200A	30	500	150	0.33

### SPECIFICATIONS (nom.)

LEE PART NUMBER	HOLE SIZE in	HOLE SIZE $\mu\text{m}$	OPEN AREA in <sup>2</sup>	TOTAL AREA in <sup>2</sup>	NUMBER OF HOLES
FSFA5000200A	0.0008	20	0.042	0.561	45200

## 656 FLANGE MOUNT

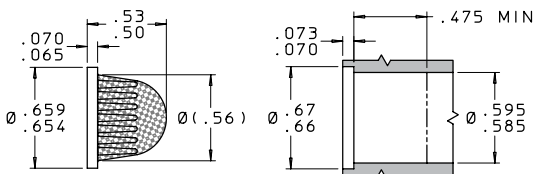

### PERFORMANCE

LEE PART NUMBER	LOHM RATE (nom.)	BURST PRES-SURE psid (min.)	COLLAPSE PRES-SURE psid (min.)	Rob NUMBER
FSFA6560200A	13	450	100	0.72

### SPECIFICATIONS (nom.)

LEE PART NUMBER	HOLE SIZE in	HOLE SIZE $\mu\text{m}$	OPEN AREA in <sup>2</sup>	TOTAL AREA in <sup>2</sup>	NUMBER OF HOLES
FSFA6560200A	0.0008	20	0.092	1.227	99000

### MATERIALS

PART	MATERIAL	SPECIFICATION
Screen	316L CRES	ASTM A 478-97
Base Washer	316L CRES	ASTM A 666 or AMS 5653
Braze	Silver Alloy	AMS 4765

Finish: All Cres Parts Passivated.

**FSBA, FSBM, FSBS GROUP**



## **BOSS MOUNTED SAFETY SCREENS**

- ❑ **Easy to install boss mounted design**
- ❑ **61 standard versions for design flexibility**
- ❑ **Maximum open screen area**
- ❑ **All stainless steel construction**
- ❑ **Hole sizes from 0.003" to 0.062"**
- ❑ **Low Lohm, high flow capability**

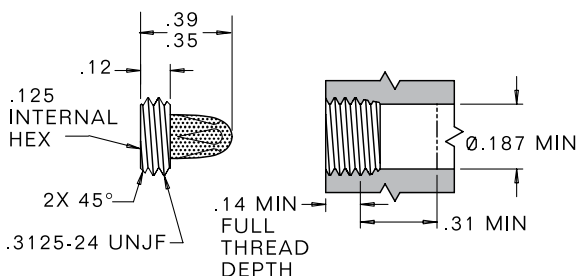

### PERFORMANCE

LEE PART NUMBER	LOHM RATE (nom.)	BURST PRESSURE psid (min.)	COLLAPSE PRESSURE psid (min.)	ROB NUMBER
FSBA3120030A	85	800	150	2.7
FSBA3120040A	85	800	200	5.4
FSBA3120060A	85	1800	550	11
FSBA3120080A	85	1200	450	21
FSBA3120100A	85	1200	450	39
FSBA3120150A	85	1200	400	131
FSBA3120200A	85	1200	300	317

### SPECIFICATIONS (nom.)

LEE PART NUMBER	HOLE SIZE in	HOLE SIZE $\mu\text{m}$	OPEN AREA in <sup>2</sup>	TOTAL AREA in <sup>2</sup>	NUMBER OF HOLES
FSBA3120030A	0.003	75	0.05	0.22	7050
FSBA3120040A	0.004	100	0.06	0.22	5100
FSBA3120060A	0.006	150	0.06	0.22	2250
FSBA3120080A	0.008	200	0.06	0.22	1250
FSBA3120100A	0.010	250	0.07	0.22	870
FSBA3120150A	0.015	380	0.08	0.22	450
FSBA3120200A	0.020	500	0.08	0.22	270

### MATERIALS

PART	MATERIAL	SPECIFICATION
Threaded Adaptor	304L CRES	AMS QQ-S-763 or AMS 5647
Screen	304L CRES	ASTM A 666
Washer	304L CRES	ASTM A 666
Braze	Silver Alloy	AMS 4774

Finish: All Cres Parts Passivated.

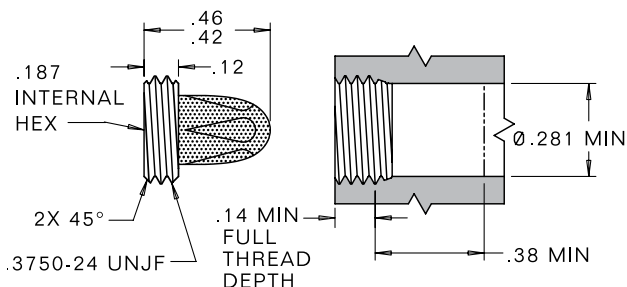

PERFORMANCE				
LEE PART NUMBER	LOHM RATE (nom.)	BURST PRESSURE psid (min.)	COLLAPSE PRESSURE psid (min.)	ROB NUMBER
FSBA3750030A	40	450	100	4.3
FSBA3750040A	40	450	150	9.5
FSBA3750060A	40	550	150	20
FSBA3750080A	40	900	200	34
FSBA3750100A	40	900	200	65
FSBA3750150A	40	900	175	247
FSBA3750200A	40	900	175	533

SPECIFICATIONS (nom.)					
LEE PART NUMBER	HOLE SIZE in	HOLE SIZE $\mu\text{m}$	OPEN AREA in <sup>2</sup>	TOTAL AREA in <sup>2</sup>	NUMBER OF HOLES
FSBA3750030A	0.003	75	0.08	0.37	11 300
FSBA3750040A	0.004	100	0.11	0.37	9 000
FSBA3750060A	0.006	150	0.11	0.37	4 000
FSBA3750080A	0.008	200	0.10	0.37	2 000
FSBA3750100A	0.010	250	0.11	0.37	1 460
FSBA3750150A	0.015	380	0.15	0.37	850
FSBA3750200A	0.020	500	0.14	0.37	450

MATERIALS		
PART	MATERIAL	SPECIFICATION
Threaded Adaptor	304L CRES	AMS QQ-S-763 or AMS 5647
Screen	304L CRES	ASTM A 666
Washer	304L CRES	ASTM A 666
Braze	Silver Alloy	AMS 4774

Finish: All Cres Parts Passivated.

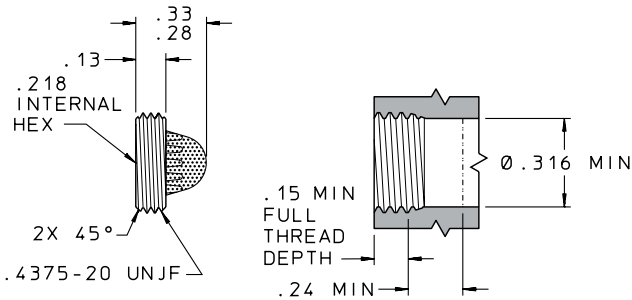

### PERFORMANCE

LEE PART NUMBER	LOHM RATE (nom.)	BURST PRESSURE psid (min.)	COLLAPSE PRESSURE psid (min.)	Rob NUMBER
FSBA4370031A	25	400	100	3.7
FSBA4370041A	20	400	100	8.0
FSBA4370061A	20	800	275	18
FSBA4370081A	20	1000	500	30
FSBA4370101A	20	1000	500	53
FSBA4370151A	20	800	275	180
FSBA4370201A	20	800	275	432

### SPECIFICATIONS (nom.)

LEE PART NUMBER	HOLE SIZE in	HOLE SIZE $\mu\text{m}$	OPEN AREA in <sup>2</sup>	TOTAL AREA in <sup>2</sup>	NUMBER OF HOLES
FSBA4370031A	0.003	75	0.07	0.30	9900
FSBA4370041A	0.004	100	0.09	0.30	7500
FSBA4370061A	0.006	150	0.10	0.30	3500
FSBA4370081A	0.008	200	0.09	0.30	1800
FSBA4370101A	0.010	250	0.09	0.30	1180
FSBA4370151A	0.015	380	0.11	0.30	620
FSBA4370201A	0.020	500	0.11	0.30	360

### MATERIALS

PART	MATERIAL	SPECIFICATION
Threaded Adaptor	304L CRES	AMS QQ-S-763 or AMS 5647
Screen	304L CRES	ASTM A 666
Washer	304L CRES	ASTM A 666
Braze	Silver Alloy	AMS 4774

Finish: All Cres Parts Passivated.

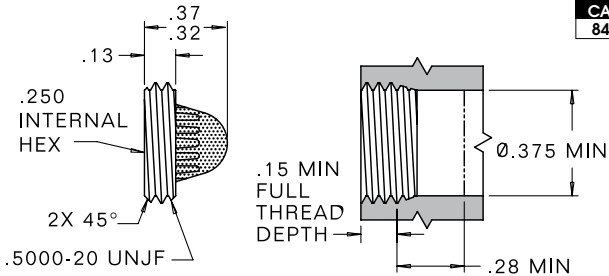

PERFORMANCE				
LEE PART NUMBER	LOHM RATE (nom.)	BURST PRESSURE psid (min.)	COLLAPSE PRESSURE psid (min.)	Rob NUMBER
FSBA5000030A	18	400	100	5
FSBA5000040A	18	400	100	1.0
FSBA5000060A	18	900	275	27
FSBA5000080A	18	1100	450	44
FSBA5000100A	18	1100	450	78
FSBA5000150A	18	1100	450	262
FSBA5000200A	18	1000	450	633

SPECIFICATIONS (nom.)					
LEE PART NUMBER	HOLE SIZE in	HOLE SIZE µm	OPEN AREA in <sup>2</sup>	TOTAL AREA in <sup>2</sup>	NUMBER OF HOLES
FSBA5000030A	0.003	75	0.10	0.44	10 350
FSBA5000040A	0.004	100	0.13	0.44	10 350
FSBA5000060A	0.006	150	0.15	0.44	5 300
FSBA5000080A	0.008	200	0.13	0.44	2 590
FSBA5000100A	0.010	250	0.14	0.44	1 740
FSBA5000150A	0.015	380	0.16	0.44	900
FSBA5000200A	0.020	500	0.17	0.44	530

MATERIALS		
PART	MATERIAL	SPECIFICATION
Threaded Adaptor	304L CRES	AMS QQ-S-763 or AMS 5647
Screen	304L CRES	ASTM A 666
Washer	304L CRES	ASTM A 666
Braze	Silver Alloy	AMS 4774

Finish: All Cres Parts Passivated.

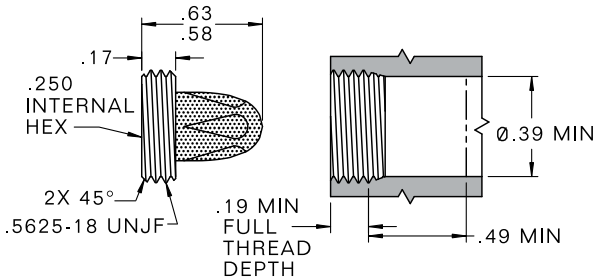
**PERFORMANCE**

LEE PART NUMBER	LOHM RATE (nom.)	BURST PRESSURE psid (min.)	COLLAPSE PRESSURE psid (min.)	Rob NUMBER
FSBA5620030A	16	450	50	9.6
FSBA5620040A	16	700	100	7.0
FSBA5620060A	16	1300	275	33
FSBA5620080A	16	1500	450	64
FSBA5620100A	16	1500	300	138
FSBA5620150A	16	1500	450	399
FSBA5620200A	16	1500	300	1123

**SPECIFICATIONS (nom.)**

LEE PART NUMBER	HOLE SIZE in	HOLE SIZE $\mu\text{m}$	OPEN AREA in <sup>2</sup>	TOTAL AREA in <sup>2</sup>	NUMBER OF HOLES
FSBA5620030A	0.003	75	0.18	0.78	25 450
FSBA5620040A	0.004	100	0.23	0.78	18 300
FSBA5620060A	0.006	150	0.25	0.78	8 840
FSBA5620080A	0.008	200	0.19	0.78	3 800
FSBA5620100A	0.010	250	0.24	0.78	3 080
FSBA5620150A	0.015	380	0.32	0.78	1 810
FSBA5620200A	0.020	500	0.30	0.78	940

**MATERIALS**

PART	MATERIAL	SPECIFICATION
Threaded Adaptor	304L CRES	AMS QQ-S-763 or AMS 5647
Screen	304L CRES	ASTM A 666
Washer	304L CRES	ASTM A 666
Braze	Silver Alloy	AMS 4774

Finish: All Cres Parts Passivated.

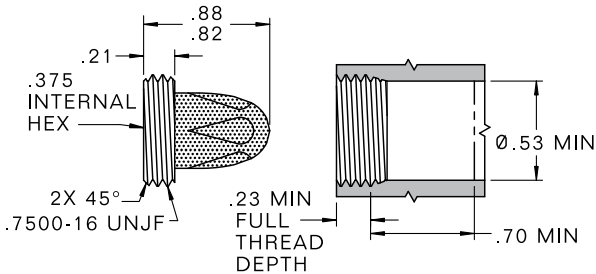

PERFORMANCE				
LEE PART NUMBER	LOHM RATE (nom.)	BURST PRESSURE psid (min.)	COLLAPSE PRESSURE psid (min.)	ROB NUMBER
FSBA7500030A	8.0	250	50	20
FSBA7500040A	8.0	300	50	43
FSBA7500060A	8.0	1000	100	97
FSBA7500080A	8.0	1100	125	138
FSBA7500100A	8.0	1100	100	301
FSBA7500150A	8.0	1100	100	1164
FSBA7500200A	8.0	1000	100	2447

SPECIFICATIONS (nom.)					
LEE PART NUMBER	HOLE SIZE in	HOLE SIZE $\mu\text{m}$	OPEN AREA in <sup>2</sup>	TOTAL AREA in <sup>2</sup>	NUMBER OF HOLES
FSBA7500030A	0.003	75	0.38	1.7	53 750
FSBA7500040A	0.004	100	0.51	1.7	39 630
FSBA7500060A	0.006	150	0.54	1.7	13 700
FSBA7500080A	0.008	200	0.41	1.7	8 600
FSBA7500100A	0.010	250	0.53	1.7	6 710
FSBA7500150A	0.015	380	0.71	1.7	4 000
FSBA7500200A	0.020	500	0.65	1.7	2 060

MATERIALS		
PART	MATERIAL	SPECIFICATION
Threaded Adaptor	304L CRES	AMS QQ-S-763 or AMS 5647
Screen	304L CRES	ASTM A 666
Washer	304L CRES	ASTM A 666
Braze	Silver Alloy	AMS 4774

Finish: All Cres Parts Passivated.

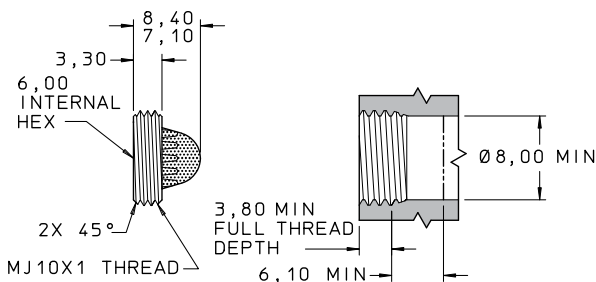

PERFORMANCE				
LEE PART NUMBER	LOHM RATE (nom.)	BURST PRESSURE kPa (min.)	COLLAPSE PRESSURE kPa (min.)	Rob NUMBER
FSBM1000071A	25	2760	690	3.7
FSBM1000101A	20	2760	690	8.0
FSBM1000151A	20	5515	1895	18
FSBM1000201A	20	6895	3450	30
FSBM1000251A	20	6895	3450	53
FSBM1000381A	20	5515	1895	180
FSBM1000501A	20	5515	1895	432

SPECIFICATIONS (nom.)					
LEE PART NUMBER	HOLE SIZE in	HOLE SIZE $\mu\text{m}$	OPEN AREA $\text{mm}^2$	TOTAL AREA $\text{mm}^2$	NUMBER OF HOLES
FSBM1000071A	0.003	75	45,0	193,0	9900
FSBM1000101A	0.004	100	58,0	193,0	7500
FSBM1000151A	0.006	150	64,5	193,0	3500
FSBM1000201A	0.008	200	58,0	193,0	1800
FSBM1000251A	0.010	250	60,0	193,0	1180
FSBM1000381A	0.015	380	71,0	193,0	620
FSBM1000501A	0.020	500	74,0	193,0	360

MATERIALS		
PART	MATERIAL	SPECIFICATION
Threaded Adaptor	304L CRES	AMS QQ-S-763 or AMS 5647
Screen	304L CRES	ASTM A 666
Washer	304L CRES	ASTM A 666
Braze	Silver Alloy	AMS 4774

Finish: All Cres Parts Passivated.

## 750 BOSS MOUNT

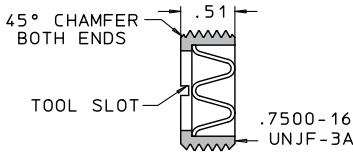
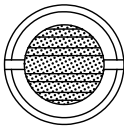

PERFORMANCE			
LEE PART NUMBER	LOHM RATE (nom.)	BURST PRESSURE psid (min.)	ROB NUMBER
FSBS7501380A	6.0	500	5 960
FSBS7501620A	6.0	500	36 870

SPECIFICATIONS (nom.)					
LEE PART NUMBER	HOLE SIZE in	HOLE SIZE $\mu\text{m}$	OPEN AREA in <sup>2</sup>	TOTAL AREA in <sup>2</sup>	NUMBER OF HOLES
FSBS7501380A	0.038	965	0.19	0.64	170
FSBS7501620A	0.062	1575	0.19	0.64	64

## 875 BOSS MOUNT

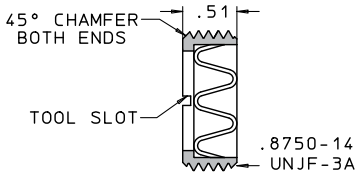
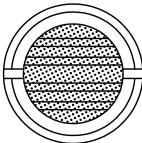

PERFORMANCE			
LEE PART NUMBER	LOHM RATE (nom.)	BURST PRESSURE psid (min.)	ROB NUMBER
FSBS8751380A	3.5	500	8 870
FSBS8751620A	3.5	500	54 850

SPECIFICATIONS (nom.)					
LEE PART NUMBER	HOLE SIZE in	HOLE SIZE $\mu\text{m}$	OPEN AREA in <sup>2</sup>	TOTAL AREA in <sup>2</sup>	NUMBER OF HOLES
FSBS8751380A	0.038	965	0.29	0.95	253
FSBS8751620A	0.062	1575	0.29	0.95	95

MATERIALS		
PART	MATERIAL	SPECIFICATION
Threaded Adaptor	304L CRES	AMS 5647
Screen	304L CRES	ASTM A240/A240M
Braze	Silver Alloy	AMS 4774

Finish: All Cres Parts Passivated.

## 106 BOSS MOUNT

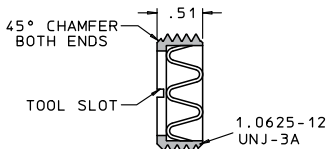
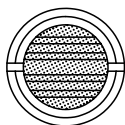

PERFORMANCE			
LEE PART NUMBER	LOHM RATE (nom.)	BURST PRESSURE psid (min.)	Rob NUMBER
FSBS1061380A	2.5	500	13 250
FSBS1061620A	2.5	500	81 960

SPECIFICATIONS (nom.)					
LEE PART NUMBER	HOLE SIZE in	HOLE SIZE $\mu\text{m}$	OPEN AREA in <sup>2</sup>	TOTAL AREA in <sup>2</sup>	NUMBER OF HOLES
FSBS1061380A	0.038	965	0.43	1.43	377
FSBS1061620A	0.062	1575	0.43	1.43	142

## 131 BOSS MOUNT

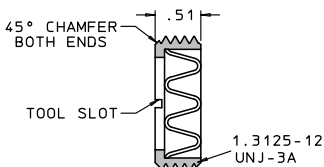
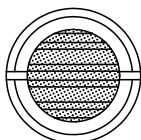

PERFORMANCE			
LEE PART NUMBER	LOHM RATE (nom.)	BURST PRESSURE psid (min.)	Rob NUMBER
FSBS1311380A	1.5	500	22 340
FSBS1311620A	1.5	500	138 190

SPECIFICATIONS (nom.)					
LEE PART NUMBER	HOLE SIZE in	HOLE SIZE $\mu\text{m}$	OPEN AREA in <sup>2</sup>	TOTAL AREA in <sup>2</sup>	NUMBER OF HOLES
FSBS1311380A	0.038	965	0.72	2.41	640
FSBS1311620A	0.062	1575	0.72	2.41	240

MATERIALS		
PART	MATERIAL	SPECIFICATION
Threaded Adaptor	304L CRES	AMS 5647
Screen	304L CRES	ASTM A240/A240M
Braze	Silver Alloy	AMS 4774

Finish: All Cres Parts Passivated.

## 162 BOSS MOUNT

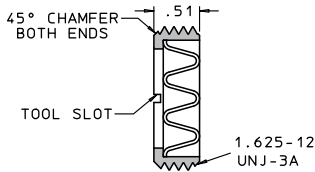
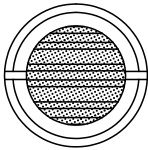

PERFORMANCE			
LEE PART NUMBER	LOHM RATE (nom.)	BURST PRESSURE psid (min.)	ROB NUMBER
FSBS1621380A	1.0	500	36 580
FSBS1621620A	1.0	500	226 290

SPECIFICATIONS (nom.)					
LEE PART NUMBER	HOLE SIZE in	HOLE SIZE $\mu\text{m}$	OPEN AREA in <sup>2</sup>	TOTAL AREA in <sup>2</sup>	NUMBER OF HOLES
FSBS1621380A	0.038	965	1.18	3.94	1 040
FSBS1621620A	0.062	1575	1.18	3.94	390

## 187 BOSS MOUNT

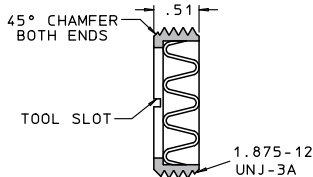
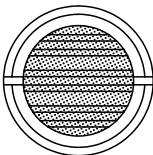

PERFORMANCE			
LEE PART NUMBER	LOHM RATE (nom.)	BURST PRESSURE psid (min.)	ROB NUMBER
FSBS1871380A	0.5	500	50 960
FSBS1871620A	0.5	500	315 200

SPECIFICATIONS (nom.)					
LEE PART NUMBER	HOLE SIZE in	HOLE SIZE $\mu\text{m}$	OPEN AREA in <sup>2</sup>	TOTAL AREA in <sup>2</sup>	NUMBER OF HOLES
FSBS1871380A	0.038	965	1.65	5.49	1 450
FSBS1871620A	0.062	1575	1.65	5.49	545

MATERIALS		
PART	MATERIAL	SPECIFICATION
Threaded Adaptor	304L CRES	AMS 5647
Screen	304L CRES	ASTM A240/A240M
Braze	Silver Alloy	AMS 4774

Finish: All Cres Parts Passivated.

FSCA GROUP

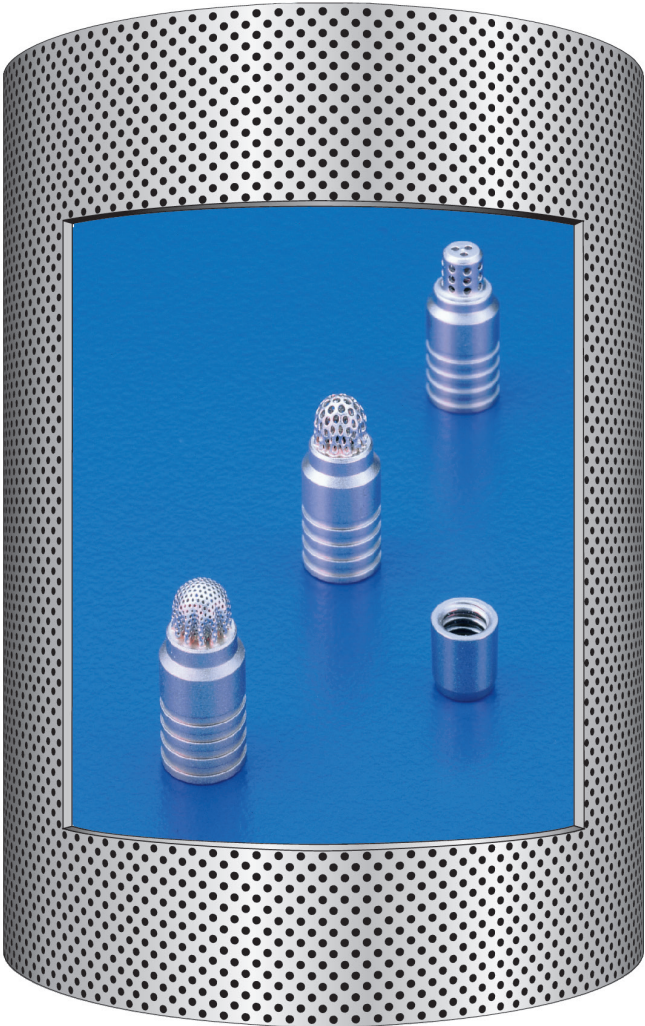

## **INSERT RETAINED SAFETY SCREENS**

- ❑ **Reliable Lee Insert retention**
- ❑ **45 standard versions for design flexibility**
- ❑ **Maximum open screen area**
- ❑ **All stainless steel construction**
- ❑ **Hole sizes from 0.003" to 0.020"**

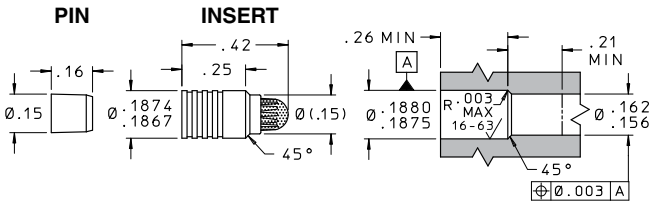

### PERFORMANCE

LEE PART NUMBER	LOHM RATE (nom.)	BURST PRESSURE psid (min.)	COLLAPSE PRESSURE psid (min.)	Rob NUMBER
FSCA1870030A	250	1500	450	0.7
FSCA1870040A	250	1800	750	1.6
FSCA1870060A	250	2400	1100	3.6
FSCA1870080A	250	3000	3000	4.2
FSCA1870100A	250	3000	2500	11
FSCA1870150A	250	3000	2200	44
FSCA1870200A	250	3000	2200	89

### SPECIFICATIONS (nom.)

LEE PART NUMBER	HOLE SIZE in	HOLE SIZE $\mu\text{m}$	OPEN AREA in <sup>2</sup>	TOTAL AREA in <sup>2</sup>	NUMBER OF HOLES
FSCA1870030A	0.003	75	0.014	0.062	1980
FSCA1870040A	0.004	100	0.019	0.062	1500
FSCA1870060A	0.006	150	0.020	0.062	700
FSCA1870080A	0.008	200	0.014	0.062	250
FSCA1870100A	0.010	250	0.019	0.062	240
FSCA1870150A	0.015	380	0.026	0.062	150
FSCA1870200A	0.020	500	0.024	0.062	80

### MATERIALS

PART	MATERIAL	SPECIFICATION
Body	304L CRES	AMS QQ-S-763 or AMS 5647
Pin	17-4PH CRES	AMS 5643
Screen	304L CRES	ASTM A 666
Braze	Silver Alloy	AMS 4774

Finish: All Cres Parts Passivated. Pins are pre-waxed. Do not degrease. Do not lubricate.

### INSTALLATION AND EXTRACTION

Tool Set Part Number ..... CUTA1870128C  
 Replacement Pin Part Number ..... JEHA1870003A  
 Installation and Extraction Procedures ..... See [Pages N26 – N28](#)

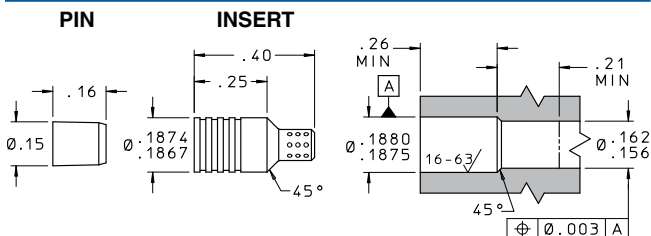

PERFORMANCE				
LEE PART NUMBER	LOHM RATE (nom.)	BURST PRESSURE psid (min.)	COLLAPSE PRESSURE psid (min.)	ROB NUMBER
FSCA1871150A	200	3000	3000	7.9
FSCA1871200A	200	3000	3000	32

SPECIFICATIONS (nom.)					
LEE PART NUMBER	HOLE SIZE in	HOLE SIZE $\mu\text{m}$	OPEN AREA in <sup>2</sup>	TOTAL AREA in <sup>2</sup>	NUMBER OF HOLES
FSCA1871150A	0.015	380	0.005	0.034	27
FSCA1871200A	0.020	510	0.009	0.034	27

MATERIALS		
PART	MATERIAL	SPECIFICATION
Body	303 CRES	QQ-S-763C
Pin	17-4PH CRES	AMS 5643

Finish: All Cres Parts Passivated. Pins are pre-waxed. Do not degrease. Do not lubricate.

INSTALLATION AND EXTRACTION	
Tool Set Part Number .....	CUTA1870128C
Replacement Pin Part Number .....	JEHA1870003A
Installation and Extraction Procedures .....	See <b>Pages N26 – N28</b>

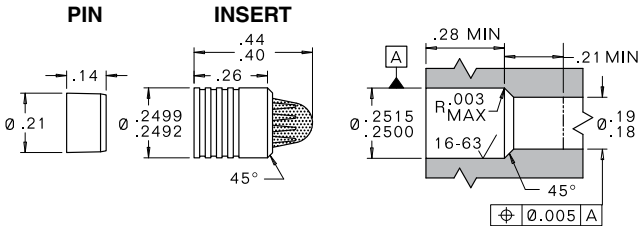

### PERFORMANCE

LEE PART NUMBER	LOHM RATE (nom.)	BURST PRESSURE psid (min.)	COLLAPSE PRESSURE psid (min.)	ROB NUMBER
FSCA2500030A	75	900	250	1.2
FSCA2500040A	75	900	250	2.5
FSCA2500060A	75	1100	375	5.8
FSCA2500080A	75	1900	1200	8.1
FSCA2500100A	75	1900	1200	17
FSCA2500150A	75	1500	1000	70
FSCA2500200A	75	1500	1000	141

### SPECIFICATIONS (nom.)

LEE PART NUMBER	HOLE SIZE in	HOLE SIZE $\mu\text{m}$	OPEN AREA in <sup>2</sup>	TOTAL AREA in <sup>2</sup>	NUMBER OF HOLES
FSCA2500030A	0.003	75	0.022	0.098	3100
FSCA2500040A	0.004	100	0.029	0.098	2330
FSCA2500060A	0.006	150	0.032	0.098	1130
FSCA2500080A	0.008	200	0.024	0.098	480
FSCA2500100A	0.010	250	0.030	0.098	390
FSCA2500150A	0.015	380	0.042	0.098	240
FSCA2500200A	0.020	500	0.037	0.098	120

### MATERIALS

PART	MATERIAL	SPECIFICATION
Body	304L CRES	AMS QQ-S-763 or AMS 5647
Pin	17-4PH CRES	AMS 5643
Screen	304L CRES	ASTM A 666
Braze	Silver Alloy	AMS 4774

Finish: All Cres Parts Passivated. Pins are pre-waxed. Do not degrease. Do not lubricate.

### INSTALLATION AND EXTRACTION

Tool Set Part Number ..... CUTA2500506C  
 Replacement Pin Part Number..... CKFA2500005A  
 Installation and Extraction Procedures ..... See **Pages N26 – N28**

# 281 Insert Retained Safety Screen

# 63

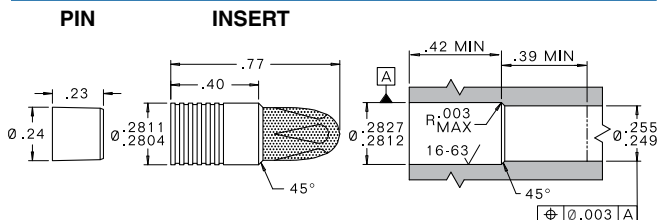

PERFORMANCE				
LEE PART NUMBER	LOHM RATE (nom.)	BURST PRESSURE psid (min.)	COLLAPSE PRESSURE psid (min.)	ROB NUMBER
FSCA2810030A	40	450	100	4.3
FSCA2810040A	40	450	150	9.5
FSCA2810060A	40	550	150	20
FSCA2810080A	40	1000	200	34
FSCA2810100A	40	900	200	65
FSCA2810150A	40	800	200	247
FSCA2810200A	40	900	175	533

SPECIFICATIONS (nom.)					
LEE PART NUMBER	HOLE SIZE in	HOLE SIZE $\mu$ m	OPEN AREA in <sup>2</sup>	TOTAL AREA in <sup>2</sup>	NUMBER OF HOLES
FSCA2810030A	0.003	75	0.08	0.37	11 300
FSCA2810040A	0.004	100	0.11	0.37	9 000
FSCA2810060A	0.006	150	0.11	0.37	4 000
FSCA2810080A	0.008	200	0.10	0.37	2 000
FSCA2810100A	0.010	250	0.11	0.37	1 460
FSCA2810150A	0.015	380	0.15	0.37	850
FSCA2810200A	0.020	500	0.14	0.37	450

MATERIALS		
PART	MATERIAL	SPECIFICATION
Body	304L CRES	AMS QQ-S-763 or AMS 5647
Pin	17-4PH CRES	AMS 5643
Screen	304L CRES	ASTM A 666
Braze	Silver Alloy	AMS 4774

Finish: All Cres Parts Passivated. Pins are pre-waxed. Do not degrease. Do not lubricate.

INSTALLATION AND EXTRACTION	
Tool Set Part Number .....	CUTA2810104C
Replacement Pin Part Number .....	JEKA2810003B
Installation and Extraction Procedures .....	See <b>Pages N26 – N28</b>

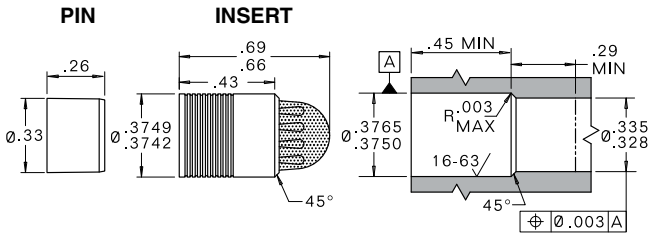

## PERFORMANCE

LEE PART NUMBER	LOHM RATE (nom.)	BURST PRESSURE psid (min.)	COLLAPSE PRESSURE psid (min.)	Rob NUMBER
FSCA3750030A	25	400	100	3.7
FSCA3750040A	20	400	100	8.0
FSCA3750060A	20	800	275	18
FSCA3750080A	20	1000	500	30
FSCA3750100A	20	1000	500	53
FSCA3750150A	20	800	275	180
FSCA3750200A	20	800	275	432

## SPECIFICATIONS (nom.)

LEE PART NUMBER	HOLE SIZE in	HOLE SIZE $\mu\text{m}$	OPEN AREA in <sup>2</sup>	TOTAL AREA in <sup>2</sup>	NUMBER OF HOLES
FSCA3750030A	0.003	75	0.07	0.30	9900
FSCA3750040A	0.004	100	0.09	0.30	7500
FSCA3750060A	0.006	150	0.10	0.30	3500
FSCA3750080A	0.008	200	0.09	0.30	1800
FSCA3750100A	0.010	250	0.09	0.30	1180
FSCA3750150A	0.015	380	0.11	0.30	620
FSCA3750200A	0.020	500	0.11	0.30	360

## MATERIALS

PART	MATERIAL	SPECIFICATION
Body	304L CRES	AMS QQ-S-763 or AMS 5647
Pin	17-4PH CRES	AMS 5643
Screen	304L CRES	ASTM A 666
Braze	Silver Alloy	AMS 4774

Finish: All Cres Parts Passivated. Pins are pre-waxed. Do not degrease. Do not lubricate.

## INSTALLATION AND EXTRACTION

Tool Set Part Number ..... CUTA3750106C  
 Replacement Pin Part Number ..... CKFA3750003A  
 Installation and Extraction Procedures ..... See [Pages N26 – N28](#)

# 500 Insert Retained Safety Screen

# 65

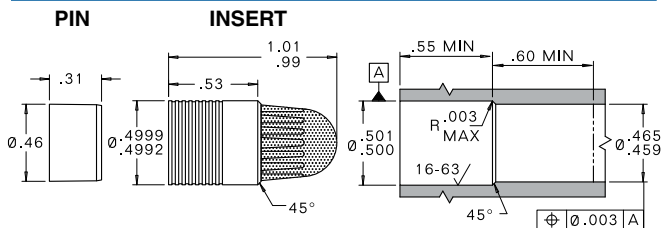

PERFORMANCE				
LEE PART NUMBER	LOHM RATE (nom.)	BURST PRESSURE psid (min.)	COLLAPSE PRESSURE psid (min.)	Rob NUMBER
FSCA5000030A	12	500	75	10
FSCA5000040A	12	900	100	19
FSCA5000060A	12	900	150	43
FSCA5000080A	12	1100	600	77
FSCA5000100A	12	1000	400	140
FSCA5000150A	12	1000	400	444
FSCA5000200A	12	900	300	1137

SPECIFICATIONS (nom.)					
LEE PART NUMBER	HOLE SIZE in	HOLE SIZE $\mu\text{m}$	OPEN AREA in <sup>2</sup>	TOTAL AREA in <sup>2</sup>	NUMBER OF HOLES
FSCA5000030A	0.003	75	0.18	0.79	25 370
FSCA5000040A	0.004	100	0.23	0.79	18 300
FSCA5000060A	0.006	150	0.24	0.79	8 490
FSCA5000080A	0.008	200	0.23	0.79	4 575
FSCA5000100A	0.010	250	0.24	0.79	3 120
FSCA5000150A	0.015	380	0.27	0.79	1 525
FSCA5000200A	0.020	500	0.30	0.79	955

MATERIALS		
PART	MATERIAL	SPECIFICATION
Body	304L CRES	AMS QQ-S-763 or AMS 5647
Pin	17-4PH CRES	AMS 5643
Screen	304L CRES	ASTM A 666
Braze	Silver Alloy	AMS 4774

Finish: All Cres Parts Passivated. Pins are pre-waxed. Do not degrease. Do not lubricate.

INSTALLATION AND EXTRACTION	
Tool Set Part Number .....	CUTA5000106C
Replacement Pin Part Number .....	CKFA5000003A
Installation and Extraction Procedures .....	See Pages N26 – N28

FSLA GROUP



## L-4 SAFETY SCREENS

- ❑ Easily locks into position
- ❑ Low cost installation hole,  
no support shoulder required
- ❑ Unique, high capacity screen design
- ❑ Maximum open screen area
- ❑ 14 standard versions for design flexibility
- ❑ Hole sizes from 0.003" to 0.020"

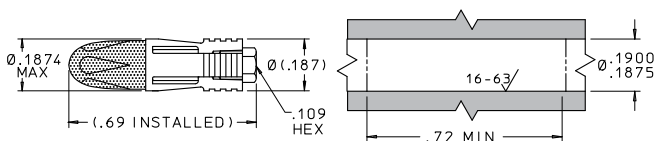

### PERFORMANCE

LEE PART NUMBER	LOHM RATE (nom.)	BURST PRESSURE psid (min.)	COLLAPSE PRESSURE psid (min.)	ROB NUMBER
FSLA1870030A	85	500	125	2.7
FSLA1870040A	85	500	150	5.4
FSLA1870060A	85	500	200	11
FSLA1870080A	85	500	350	21
FSLA1870100A	85	500	450	39
FSLA1870150A	85	500	350	131
FSLA1870200A	85	500	300	317

### SPECIFICATIONS (nom.)

LEE PART NUMBER	HOLE SIZE in	HOLE SIZE $\mu\text{m}$	OPEN AREA in <sup>2</sup>	TOTAL AREA in <sup>2</sup>	NUMBER OF HOLES
FSLA1870030A	0.003	75	0.05	0.22	7050
FSLA1870040A	0.004	100	0.06	0.22	5100
FSLA1870060A	0.006	150	0.06	0.22	2250
FSLA1870080A	0.008	200	0.06	0.22	1250
FSLA1870100A	0.010	250	0.07	0.22	870
FSLA1870150A	0.015	380	0.08	0.22	450
FSLA1870200A	0.020	500	0.08	0.22	270

### MATERIALS

PART	MATERIAL	SPECIFICATION
Body	416 CRES	QQ-S-763C
Expander Bolt	420F CRES	AMS 5620 Type II
Screen	304L CRES	ASTM A 666
Braze	Silver Alloy	AMS 4774

Finish: All Cres Parts Passivated.

### INSTALLATION AND EXTRACTION

Tool Set Part Number ..... CUTA1870528C  
 Installation and Extraction Procedures ..... See **Pages N38 – N39**

# 281 L-4 Safety Screen

69

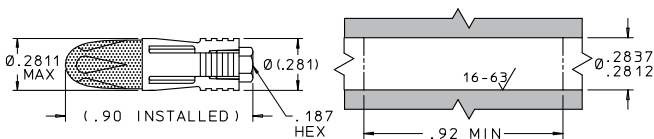

PERFORMANCE				
LEE PART NUMBER	LOHM RATE (nom.)	BURST PRESSURE psid (min.)	COLLAPSE PRESSURE psid (min.)	ROB NUMBER
FSLA2810030A	40	450	100	4.3
FSLA2810040A	40	450	150	9.5
FSLA2810060A	40	500	150	20
FSLA2810080A	40	500	200	34
FSLA2810100A	40	500	200	65
FSLA2810150A	40	500	175	247
FSLA2810200A	40	500	175	533

SPECIFICATIONS (nom.)					
LEE PART NUMBER	HOLE SIZE in	HOLE SIZE $\mu\text{m}$	OPEN AREA in <sup>2</sup>	TOTAL AREA in <sup>2</sup>	NUMBER OF HOLES
FSLA2810030A	0.003	75	0.08	0.37	11 300
FSLA2810040A	0.004	100	0.11	0.37	9 000
FSLA2810060A	0.006	150	0.11	0.37	4 000
FSLA2810080A	0.008	200	0.10	0.37	2 000
FSLA2810100A	0.010	250	0.11	0.37	1 460
FSLA2810150A	0.015	380	0.15	0.37	850
FSLA2810200A	0.020	500	0.14	0.37	450

MATERIALS		
PART	MATERIAL	SPECIFICATION
Body	416 CRES	QQ-S-763C
Expander Bolt	420F CRES	AMS 5620 Type II
Screen	304L CRES	ASTM A 666
Braze	Silver Alloy	AMS 4774

Finish: All Cres Parts Passivated.

INSTALLATION AND EXTRACTION	
Tool Set Part Number .....	CUTA2810528C
Installation and Extraction Procedures .....	See Pages N38 – N39

FSSA GROUP



## **SPRING RETAINED SAFETY SCREENS**

- ❑ Easily installed and extracted
- ❑ 14 standard versions for design flexibility
- ❑ Maximum open screen area
- ❑ All stainless steel construction
- ❑ Hole sizes from 0.003" to 0.020"

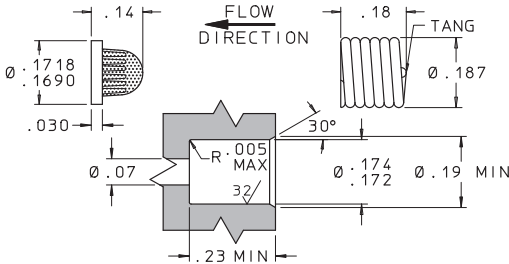

### PERFORMANCE

LEE PART NUMBER	LOHM RATE (nom.)	BURST PRESSURE psid (min.)	COLLAPSE PRESSURE psid (min.)	ROB NUMBER
FSSA1700030A	250	N/A	450	0.7
FSSA1700040A	250	N/A	750	1.6
FSSA1700060A	250	N/A	1100	3.6
FSSA1700080A	250	N/A	3000	4.2
FSSA1700100A	250	N/A	2500	11
FSSA1700150A	250	N/A	2200	44
FSSA1700200A	250	N/A	2200	89

### SPECIFICATIONS (nom.)

LEE PART NUMBER	HOLE SIZE in	HOLE SIZE $\mu\text{m}$	OPEN AREA in <sup>2</sup>	TOTAL AREA in <sup>2</sup>	NUMBER OF HOLES
FSSA1870030A	0.003	75	0.014	0.062	1980
FSSA1700040A	0.004	100	0.019	0.062	1500
FSSA1700060A	0.006	150	0.020	0.062	700
FSSA1700080A	0.008	200	0.014	0.062	250
FSSA1700100A	0.010	250	0.019	0.062	240
FSSA1700150A	0.015	380	0.026	0.062	150
FSSA1700200A	0.020	500	0.024	0.062	80

### MATERIALS

PART	MATERIAL	SPECIFICATION
Spring	302 CRES	ASTM A 313
Screen	304L CRES	ASTM A 666
Base Washer	304L CRES	ASTM A 666
Braze	Silver Alloy	AMS 4774

Finish: All Cres Parts Passivated.

### INSTALLATION AND EXTRACTION

Tool Set Part Number ..... CUTA1700128C  
 Installation and Extraction Procedures ..... See **Pages N40**

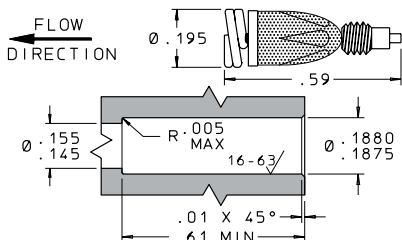

PERFORMANCE				
LEE PART NUMBER	LOHM RATE (nom.)	BURST PRESSURE psid (min.)	COLLAPSE PRESSURE psid (min.)	ROB NUMBER
FSSA1870030A	80	N/A	125	2.7
FSSA1870040B	80	N/A	125	5.4
FSSA1870060B	80	N/A	150	11
FSSA1870080B	80	N/A	150	21
FSSA1870100B	80	N/A	300	39
FSSA1870150B	80	N/A	300	131
FSSA1870200B	80	N/A	300	317

SPECIFICATIONS (nom.)					
LEE PART NUMBER	HOLE SIZE in	HOLE SIZE $\mu\text{m}$	OPEN AREA in <sup>2</sup>	TOTAL AREA in <sup>2</sup>	NUMBER OF HOLES
FSSA1870030A	0.003	75	0.05	0.22	7050
FSSA1870040B	0.004	100	0.06	0.22	5100
FSSA1870060B	0.006	150	0.07	0.22	2250
FSSA1870080B	0.008	200	0.06	0.22	1250
FSSA1870100B	0.010	250	0.07	0.22	870
FSSA1870150B	0.015	380	0.08	0.22	450
FSSA1870200B	0.020	500	0.08	0.22	270

MATERIALS		
PART	MATERIAL	SPECIFICATION
Spring	17-7PH CRES	AMS 5678
Threaded Post	303 CRES	QQ-S-763C
Base Washer	304L CRES	QQ-S-763 or AMS 5647
Screen	304L CRES	ASTM A 666
Braze	Silver Alloy	AMS 4774

Finish: All Cres Parts Passivated.

INSTALLATION AND EXTRACTION	
Tool Set Part Number .....	CUTA1870228C
Installation and Extraction Procedures .....	See <b>Pages N40</b>



## **HI-BAR<sup>®</sup> SAFETY SCREENS**

**Flange Mounted**

**Boss Mounted**

**Boss Access**

**Ring Locked Adapters**

**AS Flareless Tube To Port Adapter**

|

FSHF GROUP

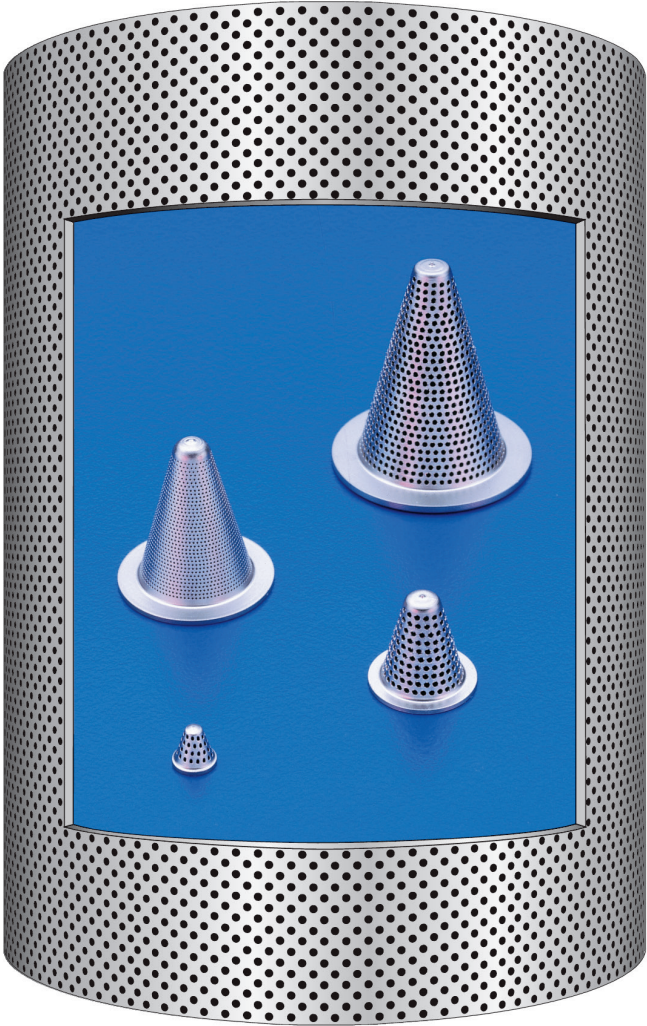

## **FLANGE MOUNTED HI-BAR® SAFETY SCREENS**

- ❑ **Rugged, high strength, flange mount design**
- ❑ **No burst or collapse up to 7500 psid when fully clogged**
- ❑ **Machined and drilled from solid bar stock**
- ❑ **222 standard versions for design flexibility**
- ❑ **High contamination carrying capacity for maximum protection**
- ❑ **Low Lohm, high flow capacity**
- ❑ **Hole sizes from 0.002" to 0.020"**
- ❑ **Materials available: Brass, MP35N, PEEK, Stainless Steel and Titanium**

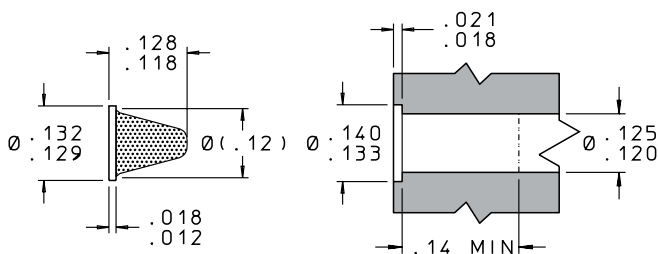

## PERFORMANCE

LEE PART NUMBER	LOHM RATE (nom.)	BURST / COLLAPSE PRESSURE psid (min.)	Rob NUMBER
FSHF1300005A	500	7500	0.06
FSHF1300007A	350	7500	0.14
FSHF1300010A	350	7500	0.2
FSHF1300015A	350	7500	0.6
FSHF1300020A	300	7500	0.8
FSHF1300025A	300	7500	1.8
FSHF1300040A	250	7500	7.3
FSHF1300050A	200	7500	16.7

## SPECIFICATIONS (nom.)

LEE PART NUMBER	HOLE SIZE in	HOLE SIZE $\mu\text{m}$	OPEN AREA in <sup>2</sup>	TOTAL AREA in <sup>2</sup>	NUMBER OF HOLES
FSHF1300005A	0.002	50	0.002	0.02	630
FSHF1300007A	0.003	75	0.002	0.02	370
FSHF1300010A	0.004	100	0.003	0.02	200
FSHF1300015A	0.006	150	0.003	0.02	110
FSHF1300020A	0.008	200	0.003	0.02	45
FSHF1300025A	0.010	250	0.003	0.02	40
FSHF1300040A	0.015	380	0.004	0.02	25
FSHF1300050A	0.020	500	0.005	0.02	14

## MATERIALS

PART	MATERIAL	SPECIFICATION	FINISH
Screen	15-5PH CRES	AMS 5659	Passivate

# HI-BAR 230 Flange Mount Safety Screen

# 79

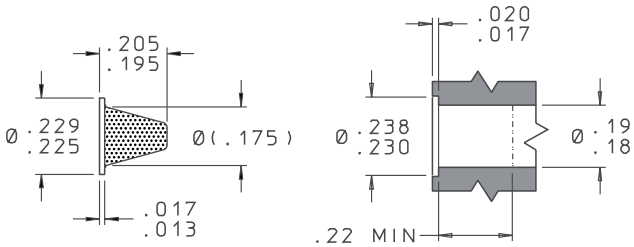

PERFORMANCE			
LEE PART NUMBER	LOHM RATE (nom.)	BURST / COLLAPSE PRESSURE psid (min.)	Rob NUMBER
FSHF2300005A	200	7500	0.2
FSHF2300007A	120	7500	0.4
FSHF2300010A	95	7500	0.8
FSHF2300015A	95	7500	1.8
FSHF2300020A	95	7500	3.4
FSHF2300025A	95	7500	5.8
FSHF2300040A	90	7500	20
FSHF2300050A	90	7500	49

SPECIFICATIONS (nom.)					
LEE PART NUMBER	HOLE SIZE in	HOLE SIZE $\mu\text{m}$	OPEN AREA in <sup>2</sup>	TOTAL AREA in <sup>2</sup>	NUMBER OF HOLES
FSHF2300005A	0.002	50	0.006	0.06	1810
FSHF2300007A	0.003	75	0.007	0.06	990
FSHF2300010A	0.004	100	0.010	0.06	795
FSHF2300015A	0.006	150	0.010	0.06	350
FSHF2300020A	0.008	200	0.010	0.06	200
FSHF2300025A	0.010	250	0.010	0.06	130
FSHF2300040A	0.015	380	0.013	0.06	70
FSHF2300050A	0.020	500	0.013	0.06	42

MATERIALS			
PART	MATERIAL	SPECIFICATION	FINISH
Screen	17-4PH CRES	AMS 5604 or AMS 5643	Passivate

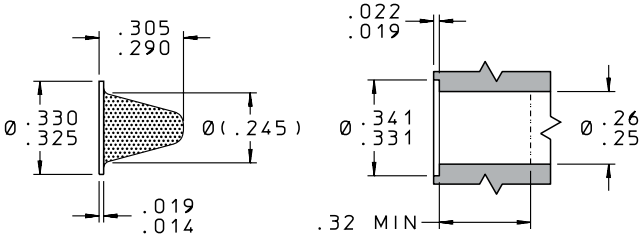

## PERFORMANCE

LEE PART NUMBER	LOHM RATE (nom.)	BURST / COLLAPSE PRESSURE psid (min.)	Rob NUMBER
FSHF3300005A	65	7500	0.4
FSHF3300007A	55	7500	0.8
FSHF3300010A	50	7500	1.9
FSHF3300015A	45	7500	4.0
FSHF3300020A	45	7500	7.4
FSHF3300025A	45	7500	12
FSHF3300040A	45	7500	46
FSHF3300050A	40	7500	107

## SPECIFICATIONS (nom.)

LEE PART NUMBER	HOLE SIZE in	HOLE SIZE $\mu\text{m}$	OPEN AREA in <sup>2</sup>	TOTAL AREA in <sup>2</sup>	NUMBER OF HOLES
FSHF3300005A	0.002	50	0.012	0.12	3820
FSHF3300007A	0.003	75	0.016	0.12	2260
FSHF3300010A	0.004	100	0.022	0.12	1750
FSHF3300015A	0.006	150	0.022	0.12	778
FSHF3300020A	0.008	200	0.022	0.12	435
FSHF3300025A	0.010	250	0.022	0.12	280
FSHF3300040A	0.015	380	0.028	0.12	158
FSHF3300050A	0.020	500	0.028	0.12	90

## MATERIALS

PART	MATERIAL	SPECIFICATION	FINISH
Screen	17-4PH CRES	AMS 5604 or AMS 5643	Passivate

# HI-BAR 380 Flange Mount Safety Screen 81

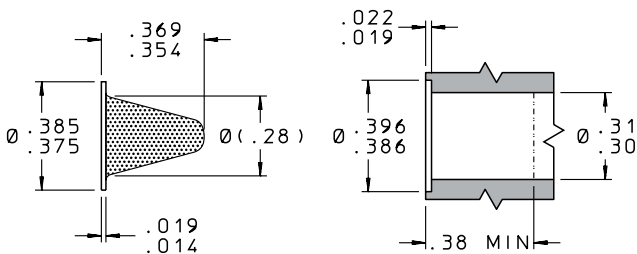

PERFORMANCE			
LEE PART NUMBER	LOHM RATE (nom.)	BURST / COLLAPSE PRESSURE psid (min.)	Rob NUMBER
FSHF3800005A	55	7500	0.5
FSHF3800007A	45	7500	1.2
FSHF3800010A	35	7500	2.6
FSHF3800015A	30	7500	5.6
FSHF3800020A	30	7500	10
FSHF3800025A	30	7500	17
FSHF3800040A	30	7500	71
FSHF3800050A	30	7500	143

SPECIFICATIONS (nom.)					
LEE PART NUMBER	HOLE SIZE in	HOLE SIZE $\mu\text{m}$	OPEN AREA in <sup>2</sup>	TOTAL AREA in <sup>2</sup>	NUMBER OF HOLES
FSHF3800005A	0.002	50	0.017	0.17	5415
FSHF3800007A	0.003	75	0.022	0.17	3110
FSHF3800010A	0.004	100	0.031	0.17	2465
FSHF3800015A	0.006	150	0.031	0.17	1095
FSHF3800020A	0.008	200	0.031	0.17	616
FSHF3800025A	0.010	250	0.031	0.17	395
FSHF3800040A	0.015	380	0.038	0.17	245
FSHF3800050A	0.020	500	0.038	0.17	120

MATERIALS			
PART	MATERIAL	SPECIFICATION	FINISH
Screen	17-4PH CRES	AMS 5604 or AMS 5643	Passivate

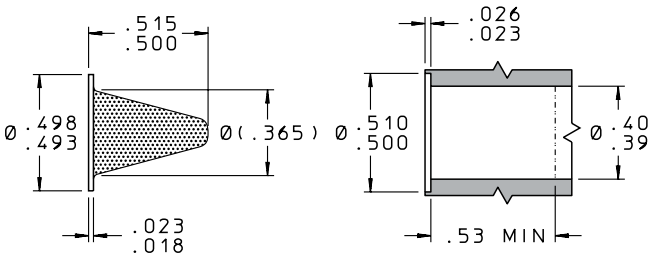

## PERFORMANCE

LEE PART NUMBER	LOHM RATE (nom.)	BURST / COLLAPSE PRESSURE psid (min.)	Rob NUMBER
FSHF4950005A	25	7500	1.0
FSHF4950007A	25	7500	2.1
FSHF4950010A	20	7500	5.1
FSHF4950015A	20	7500	11
FSHF4950020A	20	7500	20
FSHF4950025A	20	7500	34
FSHF4950040A	20	7500	115
FSHF4950050A	20	7500	268

## SPECIFICATIONS (nom.)

LEE PART NUMBER	HOLE SIZE in	HOLE SIZE $\mu\text{m}$	OPEN AREA in <sup>2</sup>	TOTAL AREA in <sup>2</sup>	NUMBER OF HOLES
FSHF4950005A	0.002	50	0.03	0.32	10 200
FSHF4950007A	0.003	75	0.04	0.32	5 660
FSHF4950010A	0.004	100	0.06	0.32	4 775
FSHF4950015A	0.006	150	0.06	0.32	2 120
FSHF4950020A	0.008	200	0.06	0.32	1 190
FSHF4950025A	0.010	250	0.06	0.32	765
FSHF4950040A	0.015	380	0.07	0.32	395
FSHF4950050A	0.020	500	0.07	0.32	225

## MATERIALS

PART	MATERIAL	SPECIFICATION	FINISH
Screen	17-4PH CRES	AMS 5604 or AMS 5643	Passivate

# HI-BAR 670 Flange Mount Safety Screen

83

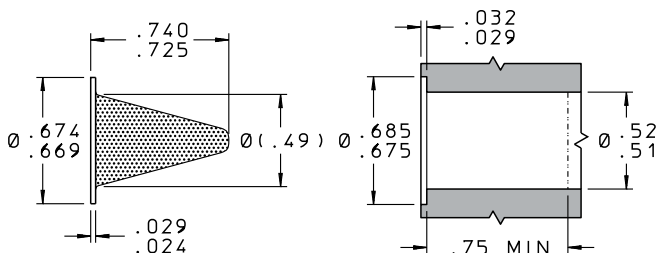

PERFORMANCE			
LEE PART NUMBER	LOHM RATE (nom.)	BURST / COLLAPSE PRESSURE psid (min.)	Rob NUMBER
FSHF6700005A	15	7500	1.9
FSHF6700007A	15	7500	4.2
FSHF6700010A	10	7500	9.3
FSHF6700015A	10	7500	20
FSHF6700020A	10	7500	37
FSHF6700025A	10	7500	62
FSHF6700040A	10	7500	230
FSHF6700050A	10	7500	530

SPECIFICATIONS (nom.)					
LEE PART NUMBER	HOLE SIZE in	HOLE SIZE $\mu\text{m}$	OPEN AREA in <sup>2</sup>	TOTAL AREA in <sup>2</sup>	NUMBER OF HOLES
FSHF6700005A	0.002	50	0.06	0.62	19 750
FSHF6700007A	0.003	75	0.08	0.62	11 315
FSHF6700010A	0.004	100	0.11	0.62	8 755
FSHF6700015A	0.006	150	0.11	0.62	3 890
FSHF6700020A	0.008	200	0.11	0.62	2 190
FSHF6700025A	0.010	250	0.11	0.62	1 400
FSHF6700040A	0.015	380	0.14	0.62	790
FSHF6700050A	0.020	500	0.14	0.62	445

MATERIALS			
PART	MATERIAL	SPECIFICATION	FINISH
Screen	17-4PH CRES	AMS 5604 or AMS 5643	Passivate



## ADDITIONAL MATERIALS

In addition to the flange mount HI-BAR screens constructed of 15-5PH CRES and 17-4PH CRES, The Lee Company has expanded this product family by releasing the same flange sizes in MP35N, titanium, brass, and PEEK. The part numbers remain similar to the original screens with the exception of the fourth number, ie. FSHF230\*001A. This digit represents the material as follows:

- ❑ \* = 1: MP35N (compliant with NACE MR0175/ISO 15156)
- ❑ \* = 2: Titanium 6AL-4V
- ❑ \* = 3: Brass per ASTM B16/B16M
- ❑ \* = 4: PolyEtherEtherKetone (PEEK)

FLANGE DIAMETER	BURST / COLLAPSE PRESSURE RATING, psid (min.)				
	15-5PH / 17-4PH	MP35N	TITANIUM	BRASS	PEEK
.130"	7500	7500	7500	4500	1000
.230"	7500	7500	7500	3000	800
.330"	7500	7500	7500	2200	600
.380"	7500	7500	7500	1600	450
.495"	7500	7500	7500	1000	400
.670"	7500	7500	7500	1000	350

**FSHB GROUP**



## **BOSS MOUNTED HI-BAR SAFETY SCREENS**

- Rugged, high strength, boss mounted design
- No burst or collapse at 7500 psid fully clogged
- Machined and drilled from solid bar stock
- 15-5PH stainless steel construction
- 150 standard versions for design flexibility
- High contamination carrying capacity for maximum protection
- Low Lohm, high flow capacity
- Hole sizes from 0.002" to 0.020"

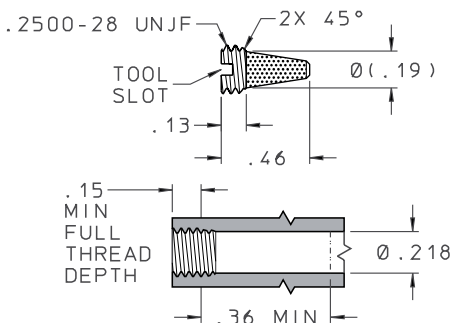

### PERFORMANCE

LEE PART NUMBER	LOHM RATE (nom.)	BURST / COLLAPSE PRESSURE psid (min.)	Rob NUMBER
FSHB2500105A	100	7500	0.3
FSHB2500107A	70	7500	0.7
FSHB2500110A	60	7500	1.7
FSHB2500115A	50	7500	3.6
FSHB2500120A	50	7500	6.7
FSHB2500125A	50	7500	11
FSHB2500140A	50	7500	40
FSHB2500150A	45	7500	95

### SPECIFICATIONS (nom.)

LEE PART NUMBER	HOLE SIZE in	HOLE SIZE $\mu\text{m}$	OPEN AREA in <sup>2</sup>	TOTAL AREA in <sup>2</sup>	NUMBER OF HOLES
FSHB2500105A	0.002	50	0.011	0.11	3500
FSHB2500107A	0.003	75	0.014	0.11	1980
FSHB2500110A	0.004	100	0.020	0.11	1590
FSHB2500115A	0.006	150	0.020	0.11	700
FSHB2500120A	0.008	200	0.020	0.11	395
FSHB2500125A	0.010	250	0.020	0.11	255
FSHB2500140A	0.015	380	0.025	0.11	140
FSHB2500150A	0.020	500	0.025	0.11	80

### MATERIALS

PART	MATERIAL	SPECIFICATION	FINISH
Screen	15-5PH CRES	AMS 5659	Passivate

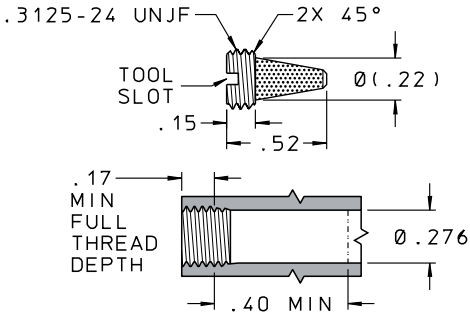

**PERFORMANCE**

LEE PART NUMBER	LOHM RATE (nom.)	BURST / COLLAPSE PRESSURE psid (min.)	Rob NUMBER
FSHB3120105A	90	7500	0.5
FSHB3120107A	60	7500	1.0
FSHB3120110A	45	7500	2.3
FSHB3120115A	45	7500	3.1
FSHB3120120A	45	7500	9.1
FSHB3120125A	45	7500	17
FSHB3120140A	35	7500	59
FSHB3120150A	35	7500	155

**SPECIFICATIONS (nom.)**

LEE PART NUMBER	HOLE SIZE in	HOLE SIZE $\mu\text{m}$	OPEN AREA in <sup>2</sup>	TOTAL AREA in <sup>2</sup>	NUMBER OF HOLES
FSHB3120105A	0.002	50	0.02	0.15	4780
FSHB3120107A	0.003	75	0.02	0.15	2690
FSHB3120110A	0.004	100	0.03	0.15	2150
FSHB3120115A	0.006	150	0.03	0.15	610
FSHB3120120A	0.008	200	0.03	0.15	535
FSHB3120125A	0.010	250	0.03	0.15	380
FSHB3120140A	0.015	380	0.04	0.15	205
FSHB3120150A	0.020	500	0.04	0.15	130

**MATERIALS**

PART	MATERIAL	SPECIFICATION	FINISH
Screen	15-5PH CRES	AMS 5659	Passivate

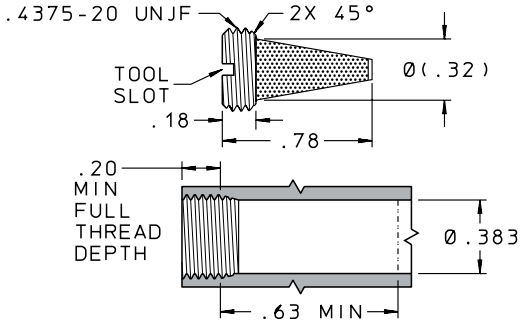

### PERFORMANCE

LEE PART NUMBER	LOHM RATE (nom.)	BURST / COLLAPSE PRESSURE psid (min.)	Rob NUMBER
FSHB4370105A	35	7500	1.2
FSHB4370107A	25	7500	2.7
FSHB4370110A	18	7500	5.9
FSHB4370115A	18	7500	13
FSHB4370120A	18	7500	23
FSHB4370125A	18	7500	40
FSHB4370140A	15	7500	148
FSHB4370150A	15	7500	339

### SPECIFICATIONS (nom.)

LEE PART NUMBER	HOLE SIZE in	HOLE SIZE $\mu\text{m}$	OPEN AREA in <sup>2</sup>	TOTAL AREA in <sup>2</sup>	NUMBER OF HOLES
FSHB4370105A	0.002	50	0.04	0.38	12 100
FSHB4370107A	0.003	75	0.05	0.38	7 075
FSHB4370110A	0.004	100	0.07	0.38	5 570
FSHB4370115A	0.006	150	0.07	0.38	2 475
FSHB4370120A	0.008	200	0.07	0.38	1 390
FSHB4370125A	0.010	250	0.07	0.38	890
FSHB4370140A	0.015	380	0.09	0.38	510
FSHB4370150A	0.020	500	0.09	0.38	285

### MATERIALS

PART	MATERIAL	SPECIFICATION	FINISH
Screen	15-5PH CRES	AMS 5659	Passivate

# HI-BAR 437 Boss Mount Safety Screen

91

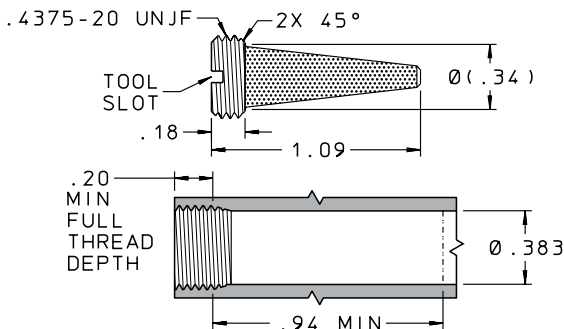

PERFORMANCE			
LEE PART NUMBER	LOHM RATE (nom.)	BURST / COLLAPSE PRESSURE psid (min.)	Rob NUMBER
FSHB4370205A	20	7500	1.9
FSHB4370207A	15	7500	4.2
FSHB4370210A	15	7500	10
FSHB4370215A	15	7500	22
FSHB4370220A	15	7500	40
FSHB4370225A	15	7500	70
FSHB4370240A	12	7500	247
FSHB4370250A	12	7500	565

SPECIFICATIONS (nom.)					
LEE PART NUMBER	HOLE SIZE in	HOLE SIZE $\mu\text{m}$	OPEN AREA in <sup>2</sup>	TOTAL AREA in <sup>2</sup>	NUMBER OF HOLES
FSHB4370205A	0.002	50	0.06	0.62	19 745
FSHB4370207A	0.003	75	0.08	0.62	11 320
FSHB4370210A	0.004	100	0.12	0.62	9 550
FSHB4370215A	0.006	150	0.12	0.62	4 245
FSHB4370220A	0.008	200	0.12	0.62	2 390
FSHB4370225A	0.010	250	0.12	0.62	1 530
FSHB4370240A	0.015	380	0.15	0.62	850
FSHB4370250A	0.020	500	0.15	0.62	475

MATERIALS			
PART	MATERIAL	SPECIFICATION	FINISH
Screen	15-5PH CRES	AMS 5659	Passivate

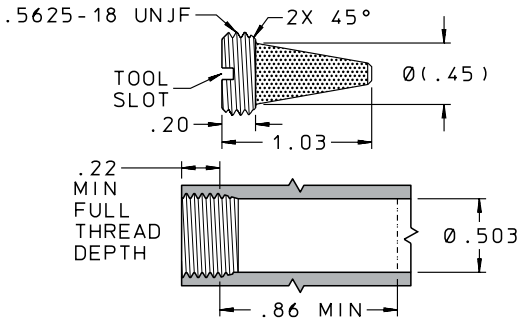

## PERFORMANCE

LEE PART NUMBER	LOHM RATE (nom.)	BURST / COLLAPSE PRESSURE psid (min.)	Rob NUMBER
FSHB5620105A	20	7500	2.4
FSHB5620107A	15	7500	5.3
FSHB5620110A	10	7500	12
FSHB5620115A	10	7500	27
FSHB5620120A	10	7500	50
FSHB5620125A	10	7500	86
FSHB5620140A	8	7500	313
FSHB5620150A	8	7500	720

## SPECIFICATIONS (nom.)

LEE PART NUMBER	HOLE SIZE in	HOLE SIZE $\mu\text{m}$	OPEN AREA in <sup>2</sup>	TOTAL AREA in <sup>2</sup>	NUMBER OF HOLES
FSHB5620105A	0.002	50	0.10	0.76	24 200
FSHB5620107A	0.003	75	0.10	0.76	14 150
FSHB5620110A	0.004	100	0.15	0.76	11 935
FSHB5620115A	0.006	150	0.15	0.76	5 305
FSHB5620120A	0.008	200	0.15	0.76	2 985
FSHB5620125A	0.010	250	0.15	0.76	1 910
FSHB5620140A	0.015	380	0.19	0.76	1 075
FSHB5620150A	0.020	500	0.19	0.76	605

## MATERIALS

PART	MATERIAL	SPECIFICATION	FINISH
Screen	15-5PH CRES	AMS 5659	Passivate

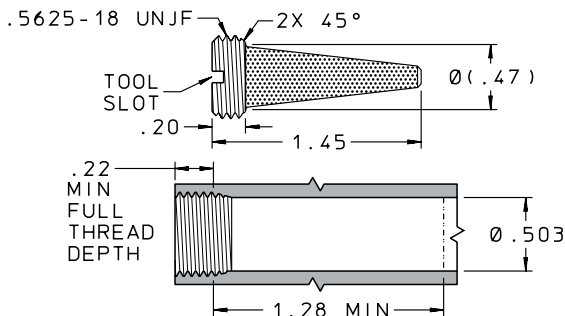

## PERFORMANCE

LEE PART NUMBER	LOHM RATE (nom.)	BURST / COLLAPSE PRESSURE psid (min.)	Rob NUMBER
FSHB5620205A	15	7500	3.8
FSHB5620207A	8	7500	8.5
FSHB5620210A	8	7500	20
FSHB5620215A	8	7500	43
FSHB5620220A	8	7500	81
FSHB5620225A	8	7500	137
FSHB5620240A	8	7500	495
FSHB5620250A	8	7500	1136

## SPECIFICATIONS (nom.)

LEE PART NUMBER	HOLE SIZE in	HOLE SIZE $\mu\text{m}$	OPEN AREA in <sup>2</sup>	TOTAL AREA in <sup>2</sup>	NUMBER OF HOLES
FSHB5620205A	0.002	50	0.12	1.22	38 850
FSHB5620207A	0.003	75	0.16	1.22	22 635
FSHB5620210A	0.004	100	0.24	1.22	19 100
FSHB5620215A	0.006	150	0.24	1.22	8 490
FSHB5620220A	0.008	200	0.24	1.22	4 775
FSHB5620225A	0.010	250	0.24	1.22	3 060
FSHB5620240A	0.015	380	0.30	1.22	1 700
FSHB5620250A	0.020	500	0.30	1.22	955

## MATERIALS

PART	MATERIAL	SPECIFICATION	FINISH
Screen	15-5PH CRES	AMS 5659	Passivate

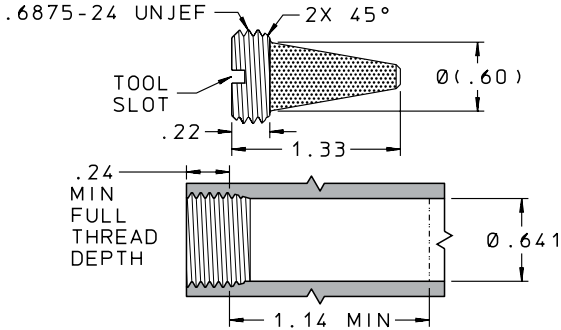

### PERFORMANCE

LEE PART NUMBER	LOHM RATE (nom.)	BURST / COLLAPSE PRESSURE psid (min.)	Rob NUMBER
FSHB6871105A	10	7500	4.0
FSHB6871107A	8	7500	9.5
FSHB6871110A	6	7500	23
FSHB6871115A	6	7500	49
FSHB6871120A	6	7500	90
FSHB6871125A	6	7500	154
FSHB6871140A	6	7500	560
FSHB6871150A	6	7500	1285

### SPECIFICATIONS (nom.)

LEE PART NUMBER	HOLE SIZE in	HOLE SIZE $\mu\text{m}$	OPEN AREA in <sup>2</sup>	TOTAL AREA in <sup>2</sup>	NUMBER OF HOLES
FSHB6871105A	0.002	50	0.13	1.37	41 380
FSHB6871107A	0.003	75	0.18	1.37	25 210
FSHB6871110A	0.004	100	0.27	1.37	21 485
FSHB6871115A	0.006	150	0.27	1.37	9 550
FSHB6871120A	0.008	200	0.27	1.37	5 370
FSHB6871125A	0.010	250	0.27	1.37	3 440
FSHB6871140A	0.015	380	0.34	1.37	1 925
FSHB6871150A	0.020	500	0.34	1.37	1 080

### MATERIALS

PART	MATERIAL	SPECIFICATION	FINISH
Screen	15-5PH CRES	AMS 5659	Passivate

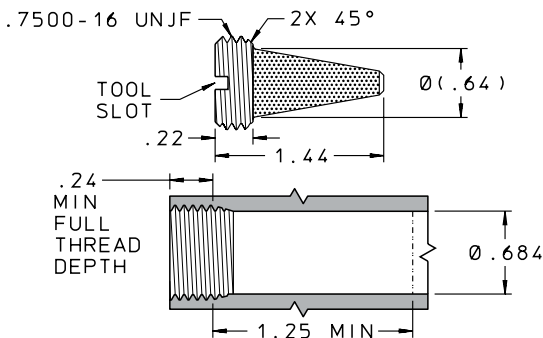

PERFORMANCE			
LEE PART NUMBER	LOHM RATE (nom.)	BURST / COLLAPSE PRESSURE psid (min.)	ROB NUMBER
FSHB7500105A	8	7500	4.0
FSHB7500107A	7	7500	11
FSHB7500110A	5	7500	26
FSHB7500115A	5	7500	56
FSHB7500120A	5	7500	104
FSHB7500125A	5	7500	177
FSHB7500140A	5	7500	643
FSHB7500150A	5	7500	1475

SPECIFICATIONS (nom.)					
LEE PART NUMBER	HOLE SIZE in	HOLE SIZE $\mu\text{m}$	OPEN AREA in <sup>2</sup>	TOTAL AREA in <sup>2</sup>	NUMBER OF HOLES
FSHB7500105A	0.002	50	0.14	1.57	44 560
FSHB7500107A	0.003	75	0.20	1.57	28 890
FSHB7500110A	0.004	100	0.31	1.57	24 670
FSHB7500115A	0.006	150	0.31	1.57	10 965
FSHB7500120A	0.008	200	0.31	1.57	6 165
FSHB7500125A	0.010	250	0.31	1.57	3 950
FSHB7500140A	0.015	380	0.39	1.57	2 210
FSHB7500150A	0.020	500	0.39	1.57	1 240

MATERIALS			
PART	MATERIAL	SPECIFICATION	FINISH
Screen	15-5PH CRES	AMS 5659	Passivate

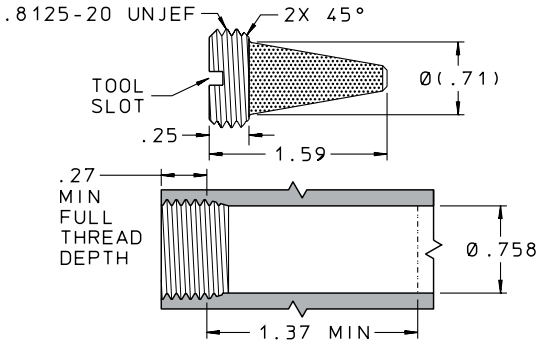

### PERFORMANCE

LEE PART NUMBER	LOHM RATE (nom.)	BURST / COLLAPSE PRESSURE psid (min.)	Rob NUMBER
FSHB8121105A	6	7500	5.0
FSHB8121107A	5	7500	13
FSHB8121110A	4	7500	33
FSHB8121115A	4	7500	70
FSHB8121120A	4	7500	131
FSHB8121125A	4	7500	223
FSHB8121140A	4	7500	742
FSHB8121150A	4	7500	1701

### SPECIFICATIONS (nom.)

LEE PART NUMBER	HOLE SIZE in	HOLE SIZE $\mu\text{m}$	OPEN AREA in <sup>2</sup>	TOTAL AREA in <sup>2</sup>	NUMBER OF HOLES
FSHB8121105A	0.002	50	0.18	1.96	57 295
FSHB8121107A	0.003	75	0.26	1.96	36 780
FSHB8121110A	0.004	100	0.39	1.96	31 050
FSHB8121115A	0.006	150	0.39	1.96	13 795
FSHB8121120A	0.008	200	0.39	1.96	7 760
FSHB8121125A	0.010	250	0.39	1.96	4 970
FSHB8121140A	0.015	380	0.45	1.96	2 550
FSHB8121150A	0.020	500	0.45	1.96	1 430

### MATERIALS

PART	MATERIAL	SPECIFICATION	FINISH
Screen	15-5PH CRES	AMS 5659	Passivate

# HI-BAR 875 Boss Mount Safety Screen

97

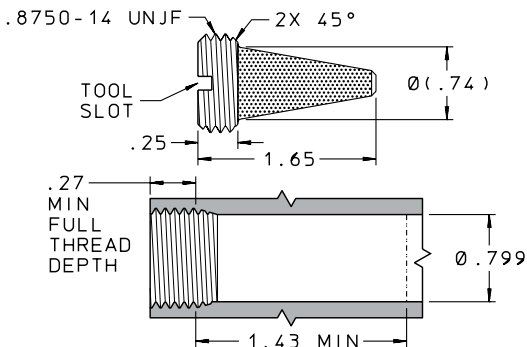

PERFORMANCE			
LEE PART NUMBER	LOHM RATE (nom.)	BURST / COLLAPSE PRESSURE psid (min.)	ROB NUMBER
FSHB8750107A	5	7500	15
FSHB8750110A	4	7500	35
FSHB8750115A	4	7500	76
FSHB8750120A	4	7500	141
FSHB8750125A	4	7500	240
FSHB8750140A	4	7500	806
FSHB8750150A	4	7500	1856

SPECIFICATIONS (nom.)					
LEE PART NUMBER	HOLE SIZE in	HOLE SIZE $\mu\text{m}$	OPEN AREA in <sup>2</sup>	TOTAL AREA in <sup>2</sup>	NUMBER OF HOLES
FSHB8750107A	0.003	75	0.28	2.12	39 610
FSHB8750110A	0.004	100	0.42	2.12	33 420
FSHB8750115A	0.006	150	0.42	2.12	14 855
FSHB8750120A	0.008	200	0.42	2.12	8 355
FSHB8750125A	0.010	250	0.42	2.12	5 350
FSHB8750140A	0.015	380	0.49	2.12	2 770
FSHB8750150A	0.020	500	0.49	2.12	1 560

MATERIALS			
PART	MATERIAL	SPECIFICATION	FINISH
Screen	15-5PH CRES	AMS 5659	Passivate

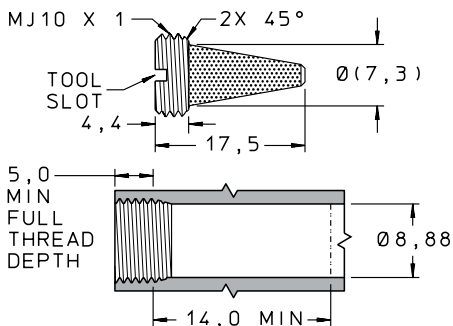

## PERFORMANCE

LEE PART NUMBER	LOHM RATE (nom.)	BURST / COLLAPSE PRESSURE bar (min.)	Rob NUMBER
FSHB1003105M	45	520	0.8
FSHB1003107M	35	520	2.1
FSHB1003110M	25	520	4.8
FSHB1003115M	25	520	10
FSHB1003120M	25	520	19
FSHB1003125M	25	520	32
FSHB1003140M	20	520	119
FSHB1003150M	20	520	273

## SPECIFICATIONS (nom.)

LEE PART NUMBER	HOLE SIZE in	HOLE SIZE $\mu\text{m}$	OPEN AREA $\text{mm}^2$	TOTAL AREA $\text{mm}^2$	NUMBER OF HOLES
FSHB1003105M	0.002	50	17	190	8650
FSHB1003107M	0.003	75	26	190	5700
FSHB1003110M	0.004	100	37	190	4565
FSHB1003115M	0.006	150	37	190	2030
FSHB1003120M	0.008	200	37	190	1140
FSHB1003125M	0.010	250	37	190	750
FSHB1003140M	0.015	380	47	190	410
FSHB1003150M	0.020	500	47	190	230

## MATERIALS

PART	MATERIAL	SPECIFICATION	FINISH
Screen	15-5PH CRES	AMS 5659	Passivate

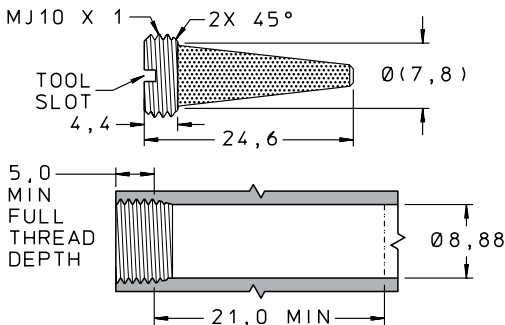

PERFORMANCE			
LEE PART NUMBER	LOHM RATE (nom.)	BURST / COLLAPSE PRESSURE bar (min.)	Rob NUMBER
FSHB1003205M	40	520	1.4
FSHB1003207M	30	520	3.5
FSHB1003210M	20	520	8.2
FSHB1003215M	20	520	18
FSHB1003220M	20	520	33
FSHB1003225M	20	520	55
FSHB1003240M	17	520	202
FSHB1003250M	17	520	464

SPECIFICATIONS (nom.)					
LEE PART NUMBER	HOLE SIZE in	HOLE SIZE $\mu\text{m}$	OPEN AREA $\text{mm}^2$	TOTAL AREA $\text{mm}^2$	NUMBER OF HOLES
FSHB1003205M	0.002	50	29	320	14 770
FSHB1003207M	0.003	75	43	320	9 430
FSHB1003210M	0.004	100	63	320	7 770
FSHB1003215M	0.006	150	63	320	3 455
FSHB1003220M	0.008	200	63	320	1 945
FSHB1003225M	0.010	250	63	320	1 280
FSHB1003240M	0.015	380	79	320	695
FSHB1003250M	0.020	500	79	320	390

MATERIALS			
PART	MATERIAL	SPECIFICATION	FINISH
Screen	15-5PH CRES	AMS 5659	Passivate

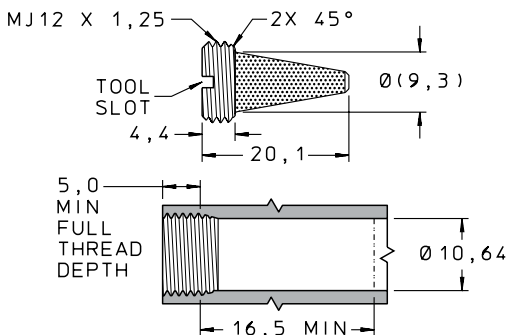

### PERFORMANCE

LEE PART NUMBER	LOHM RATE (nom.)	BURST / COLLAPSE PRESSURE bar (min.)	Rob NUMBER
FSHB1203105M	28	520	1.4
FSHB1203107M	20	520	3.3
FSHB1203110M	15	520	7.6
FSHB1203115M	15	520	16
FSHB1203120M	15	520	30
FSHB1203125M	15	520	53
FSHB1203140M	14	520	186
FSHB1203150M	14	520	428

### SPECIFICATIONS (nom.)

LEE PART NUMBER	HOLE SIZE in	HOLE SIZE $\mu\text{m}$	OPEN AREA $\text{mm}^2$	TOTAL AREA $\text{mm}^2$	NUMBER OF HOLES
FSHB1203105M	0.002	50	28	300	14 260
FSHB1203107M	0.003	75	40	300	8 775
FSHB1203110M	0.004	100	58	300	7 155
FSHB1203115M	0.006	150	58	300	3 180
FSHB1203120M	0.008	200	58	300	1 790
FSHB1203125M	0.010	250	58	300	1 180
FSHB1203140M	0.015	380	73	300	640
FSHB1203150M	0.020	500	73	300	360

### MATERIALS

PART	MATERIAL	SPECIFICATION	FINISH
Screen	15-5PH CRES	AMS 5659	Passivate

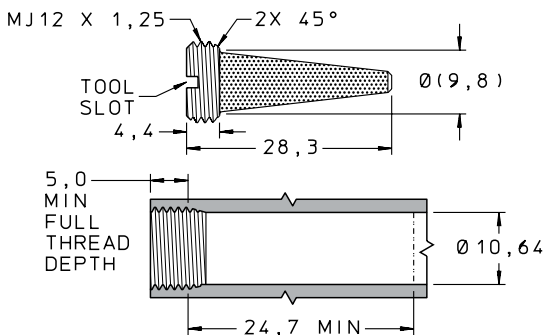

PERFORMANCE			
LEE PART NUMBER	LOHM RATE (nom.)	BURST / COLLAPSE PRESSURE bar (min.)	Rob NUMBER
FSHB1203205M	22	520	2.2
FSHB1203207M	18	520	5.4
FSHB1203210M	14	520	12
FSHB1203215M	14	520	27
FSHB1203220M	14	520	50
FSHB1203225M	14	520	86
FSHB1203240M	13	520	305
FSHB1203250M	13	520	702

SPECIFICATIONS (nom.)					
LEE PART NUMBER	HOLE SIZE in	HOLE SIZE $\mu\text{m}$	OPEN AREA $\text{mm}^2$	TOTAL AREA $\text{mm}^2$	NUMBER OF HOLES
FSHB1203205M	0.002	50	45	490	22 900
FSHB1203207M	0.003	75	65	490	14 255
FSHB1203210M	0.004	100	95	490	11 720
FSHB1203215M	0.006	150	95	490	5 210
FSHB1203220M	0.008	200	95	490	2 930
FSHB1203225M	0.010	250	95	490	1 935
FSHB1203240M	0.015	380	120	490	1 050
FSHB1203250M	0.020	500	120	490	590

MATERIALS			
PART	MATERIAL	SPECIFICATION	FINISH
Screen	15-5PH CRES	AMS 5659	Passivate

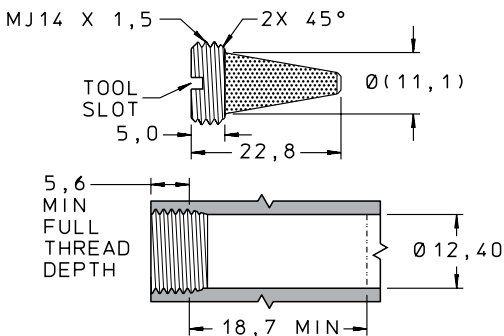

### PERFORMANCE

LEE PART NUMBER	LOHM RATE (nom.)	BURST / COLLAPSE PRESSURE bar (min.)	Rob NUMBER
FSHB1403105M	21	520	1.8
FSHB1403107M	16	520	4.4
FSHB1403110M	11	520	10
FSHB1403115M	11	520	23
FSHB1403120M	11	520	42
FSHB1403125M	11	520	73
FSHB1403140M	9	520	255
FSHB1403150M	9	520	589

### SPECIFICATIONS (nom.)

LEE PART NUMBER	HOLE SIZE in	HOLE SIZE $\mu\text{m}$	OPEN AREA $\text{mm}^2$	TOTAL AREA $\text{mm}^2$	NUMBER OF HOLES
FSHB1403105M	0.002	50	38	410	19 350
FSHB1403107M	0.003	75	53	410	11 620
FSHB1403110M	0.004	100	81	410	9 995
FSHB1403115M	0.006	150	81	410	4 440
FSHB1403120M	0.008	200	81	410	2 500
FSHB1403125M	0.010	250	81	410	1 650
FSHB1403140M	0.015	380	100	410	875
FSHB1403150M	0.020	500	100	410	495

### MATERIALS

PART	MATERIAL	SPECIFICATION	FINISH
Screen	15-5PH CRES	AMS 5659	Passivate

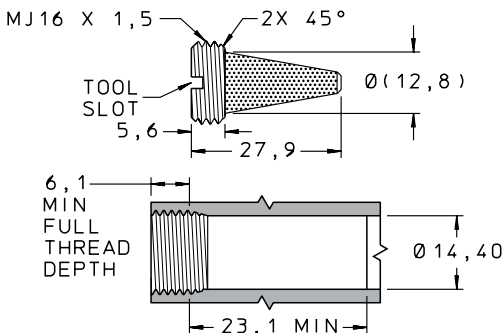

PERFORMANCE			
LEE PART NUMBER	LOHM RATE (nom.)	BURST / COLLAPSE PRESSURE bar (min.)	Rob NUMBER
FSHB1603105M	12	520	2.7
FSHB1603107M	10	520	7.0
FSHB1603110M	8	520	16
FSHB1603115M	8	520	33
FSHB1603120M	8	520	61
FSHB1603125M	8	520	109
FSHB1603140M	8	520	380
FSHB1603150M	8	520	880

SPECIFICATIONS (nom.)					
LEE PART NUMBER	HOLE SIZE in	HOLE SIZE $\mu\text{m}$	OPEN AREA $\text{mm}^2$	TOTAL AREA $\text{mm}^2$	NUMBER OF HOLES
FSHB1603105M	0.002	50	55	590	28 010
FSHB1603107M	0.003	75	80	590	18 100
FSHB1603110M	0.004	100	120	590	14 800
FSHB1603115M	0.006	150	120	590	6 580
FSHB1603120M	0.008	200	120	590	3 700
FSHB1603125M	0.010	250	120	590	2 440
FSHB1603140M	0.015	380	150	590	1 315
FSHB1603150M	0.020	500	150	590	740

MATERIALS			
PART	MATERIAL	SPECIFICATION	FINISH
Screen	15-5PH CRES	AMS 5659	Passivate

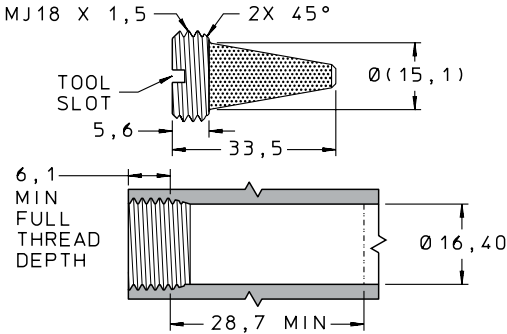

### PERFORMANCE

LEE PART NUMBER	LOHM RATE (nom.)	BURST / COLLAPSE PRESSURE bar (min.)	Rob NUMBER
FSHB1803105M	10	520	3.9
FSHB1803107M	8	520	10
FSHB1803110M	6	520	22
FSHB1803115M	6	520	47
FSHB1803120M	6	520	88
FSHB1803125M	6	520	155
FSHB1803140M	6	520	527
FSHB1803150M	6	520	1208

### SPECIFICATIONS (nom.)

LEE PART NUMBER	HOLE SIZE in	HOLE SIZE $\mu\text{m}$	OPEN AREA $\text{mm}^2$	TOTAL AREA $\text{mm}^2$	NUMBER OF HOLES
FSHB1803105M	0.002	50	80	860	40 700
FSHB1803107M	0.003	75	120	860	27 160
FSHB1803110M	0.004	100	170	860	20 970
FSHB1803115M	0.006	150	170	860	9 320
FSHB1803120M	0.008	200	170	860	5 245
FSHB1803125M	0.010	250	170	860	3 465
FSHB1803140M	0.015	380	206	860	1 810
FSHB1803150M	0.020	500	206	860	1 015

### MATERIALS

PART	MATERIAL	SPECIFICATION	FINISH
Screen	15-5PH CRES	AMS 5659	Passivate

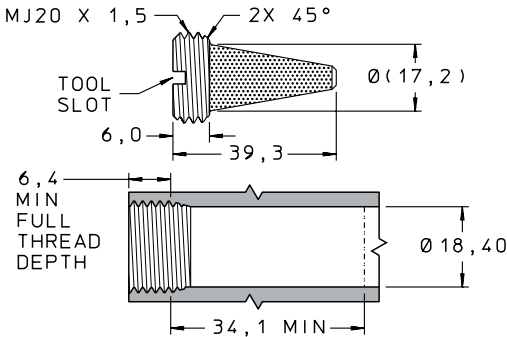

PERFORMANCE			
LEE PART NUMBER	LOHM RATE (nom.)	BURST / COLLAPSE PRESSURE bar (min.)	ROB NUMBER
FSHB2003105M	8	520	5.3
FSHB2003107M	7	520	13
FSHB2003110M	5	520	31
FSHB2003115M	5	520	64
FSHB2003120M	5	520	118
FSHB2003125M	5	520	210
FSHB2003140M	5	520	718
FSHB2003150M	5	520	1642

SPECIFICATIONS (nom.)					
LEE PART NUMBER	HOLE SIZE in	HOLE SIZE $\mu\text{m}$	OPEN AREA $\text{mm}^2$	TOTAL AREA $\text{mm}^2$	NUMBER OF HOLES
FSHB2003105M	0.002	50	106	1160	53 985
FSHB2003107M	0.003	75	155	1160	35 080
FSHB2003110M	0.004	100	230	1160	29 280
FSHB2003115M	0.006	150	230	1160	12 610
FSHB2003120M	0.008	200	230	1160	7 095
FSHB2003125M	0.010	250	230	1160	4 685
FSHB2003140M	0.015	380	280	1160	2 470
FSHB2003150M	0.020	500	280	1160	1 380

MATERIALS			
PART	MATERIAL	SPECIFICATION	FINISH
Screen	15-5PH CRES	AMS 5659	Passivate

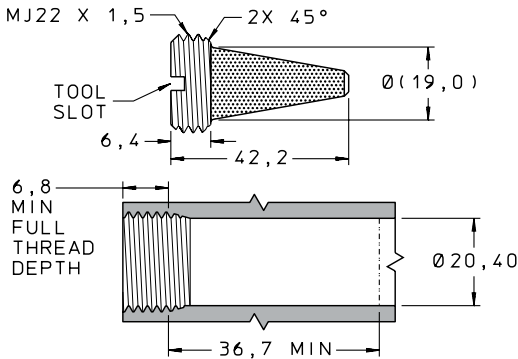

## PERFORMANCE

LEE PART NUMBER	LOHM RATE (nom.)	BURST / COLLAPSE PRESSURE bar (min.)	Rob NUMBER
FSHB2203107M	5	520	16
FSHB2203110M	4	520	35
FSHB2203115M	4	520	77
FSHB2203120M	4	520	140
FSHB2203125M	4	520	245
FSHB2203140M	4	520	861
FSHB2203150M	4	520	1975

## SPECIFICATIONS (nom.)

LEE PART NUMBER	HOLE SIZE in	HOLE SIZE $\mu\text{m}$	OPEN AREA $\text{mm}^2$	TOTAL AREA $\text{mm}^2$	NUMBER OF HOLES
FSHB2203107M	0.003	75	190	1400	41 680
FSHB2203110M	0.004	100	270	1400	33 300
FSHB2203115M	0.006	150	270	1400	14 805
FSHB2203120M	0.008	200	270	1400	8 325
FSHB2203125M	0.010	250	336	1400	5 500
FSHB2203140M	0.015	380	336	1400	2 960
FSHB2203150M	0.020	500	336	1400	1 660

## MATERIALS

PART	MATERIAL	SPECIFICATION	FINISH
Screen	15-5PH CRES	AMS 5659	Passivate



# 108 Lee Safety Screens

**BASA GROUP**



## HI-BAR BOSS ACCESS SAFETY SCREENS

- ❑ Unique, high strength, one-piece, threaded design
- ❑ Easy access for inspection and cleaning
- ❑ No burst or collapse at 7500 psid fully clogged
- ❑ Machined and drilled from solid bar stock
- ❑ 15-5PH and 17-4PH stainless steel construction
- ❑ High contamination carrying capacity for maximum protection
- ❑ Low Lohm, high flow capacity

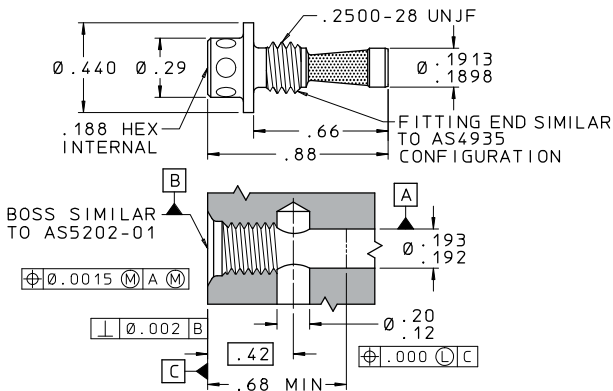

### PERFORMANCE

LEE PART NUMBER	LOHM RATE (nom.)	BURST / COLLAPSE PRESSURE psid (min.)	Rob NUMBER
BASA2501070A	90	7500	0.9
BASA2501100A	65	7500	1.9
BASA2501150A	65	7500	4.2
BASA2501200A	65	7500	7.8
BASA2501251A	65	7500	13
BASA2501401A	65	7500	48
BASA2501502A	65	7500	107

### SPECIFICATIONS (nom.)

LEE PART NUMBER	HOLE SIZE in	HOLE SIZE $\mu\text{m}$	OPEN AREA in <sup>2</sup>	TOTAL AREA in <sup>2</sup>	NUMBER OF HOLES
BASA2501070A	0.003	75	0.016	0.12	2265
BASA2501100A	0.004	100	0.023	0.12	1830
BASA2501150A	0.006	150	0.023	0.12	815
BASA2501200A	0.008	200	0.023	0.12	460
BASA2501251A	0.010	250	0.023	0.12	295
BASA2501401A	0.015	380	0.029	0.12	165
BASA2501502A	0.020	500	0.029	0.12	90

### MATERIALS

PART	MATERIAL	SPECIFICATION	FINISH
Screen	15-5PH CRES	AMS 5659	Passivate

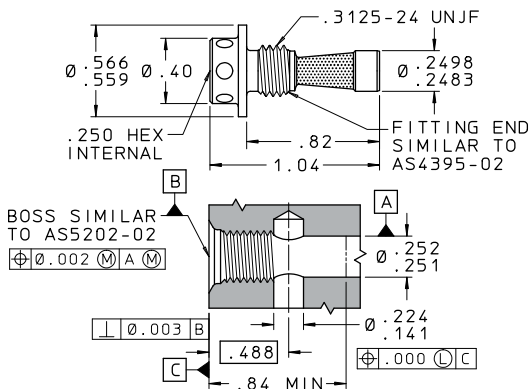

PERFORMANCE			
LEE PART NUMBER	LOHM RATE (nom.)	BURST / COLLAPSE PRESSURE psid (min.)	Rob NUMBER
BASA3121070A	60	7500	1.3
BASA3121100A	45	7500	3.0
BASA3121151A	45	7500	6.5
BASA3121201A	45	7500	12
BASA3121251A	45	7500	21
BASA3121402A	45	7500	76
BASA3121502A	45	7500	179

SPECIFICATIONS (nom.)					
LEE PART NUMBER	HOLE SIZE in	HOLE SIZE $\mu\text{m}$	OPEN AREA in <sup>2</sup>	TOTAL AREA in <sup>2</sup>	NUMBER OF HOLES
BASA3121070A	0.003	75	0.025	0.19	3535
BASA3121100A	0.004	100	0.036	0.19	2865
BASA3121151A	0.006	150	0.036	0.19	1275
BASA3121201A	0.008	200	0.036	0.19	715
BASA3121251A	0.010	250	0.036	0.19	460
BASA3121402A	0.015	380	0.046	0.19	260
BASA3121502A	0.020	500	0.046	0.19	150

MATERIALS			
PART	MATERIAL	SPECIFICATION	FINISH
Screen	15-5PH CRES	AMS 5659	Passivate

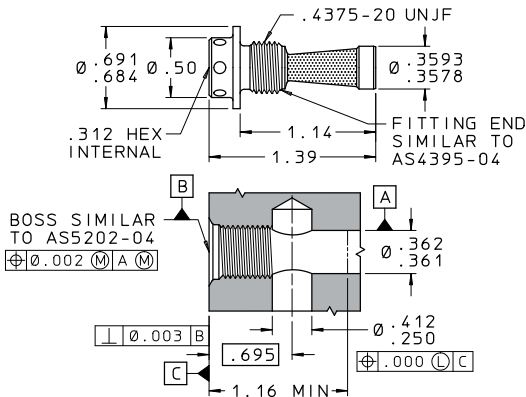

### PERFORMANCE

LEE PART NUMBER	LOHM RATE (nom.)	BURST / COLLAPSE PRESSURE psid (min.)	Rob NUMBER
BASA4371070A	20	7500	3.0
BASA4371100A	20	7500	7.1
BASA4371151A	20	7500	15
BASA4371201A	20	7500	28
BASA4371251A	20	7500	48
BASA4371402A	20	7500	180
BASA4371502A	20	7500	416

### SPECIFICATIONS (nom.)

LEE PART NUMBER	HOLE SIZE in	HOLE SIZE $\mu\text{m}$	OPEN AREA in <sup>2</sup>	TOTAL AREA in <sup>2</sup>	NUMBER OF HOLES
BASA4371070A	0.003	75	0.057	0.44	8065
BASA4371100A	0.004	100	0.084	0.44	6685
BASA4371151A	0.006	150	0.084	0.44	2970
BASA4371201A	0.008	200	0.084	0.44	1670
BASA4371251A	0.010	250	0.084	0.44	1070
BASA4371402A	0.015	380	0.110	0.44	620
BASA4371502A	0.020	500	0.110	0.44	350

### MATERIALS

PART	MATERIAL	SPECIFICATION	FINISH
Screen	15-5PH CRES	AMS 5659	Passivate

# HI-BAR 562 AS Boss Access Safety Screen 113

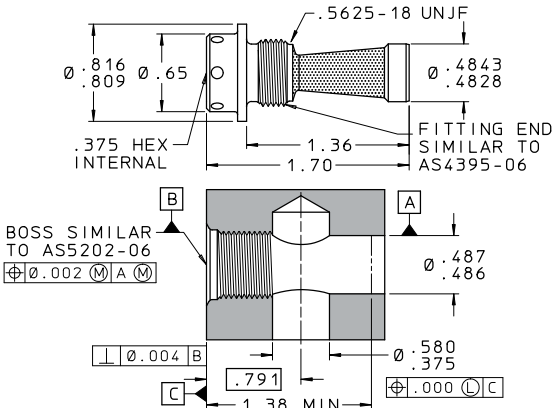

## PERFORMANCE

LEE PART NUMBER	LOHM RATE (nom.)	BURST / COLLAPSE PRESSURE psid (min.)	Rob NUMBER
BASA5621070A	15	7500	5.3
BASA5621101A	12	7500	13
BASA5621151A	12	7500	27
BASA5621201A	12	7500	50
BASA5621251A	12	7500	86
BASA5621402A	12	7500	313
BASA5621502A	12	7500	720

## SPECIFICATIONS (nom.)

LEE PART NUMBER	HOLE SIZE in	HOLE SIZE $\mu\text{m}$	OPEN AREA in <sup>2</sup>	TOTAL AREA in <sup>2</sup>	NUMBER OF HOLES
BASA5621070A	0.003	75	0.10	0.78	14 145
BASA5621101A	0.004	100	0.15	0.78	11 935
BASA5621151A	0.006	150	0.15	0.78	5 305
BASA5621201A	0.008	200	0.15	0.78	2 985
BASA5621251A	0.010	250	0.15	0.78	1 910
BASA5621402A	0.015	380	0.19	0.78	1 075
BASA5621502A	0.020	500	0.19	0.78	605

## MATERIALS

PART	MATERIAL	SPECIFICATION	FINISH
Screen	15-5PH CRES	AMS 5659	Passivate

# 114 Lee Safety Screens

**FSIK, FSIL, FSIP, FSIJ, FSIA GROUP**

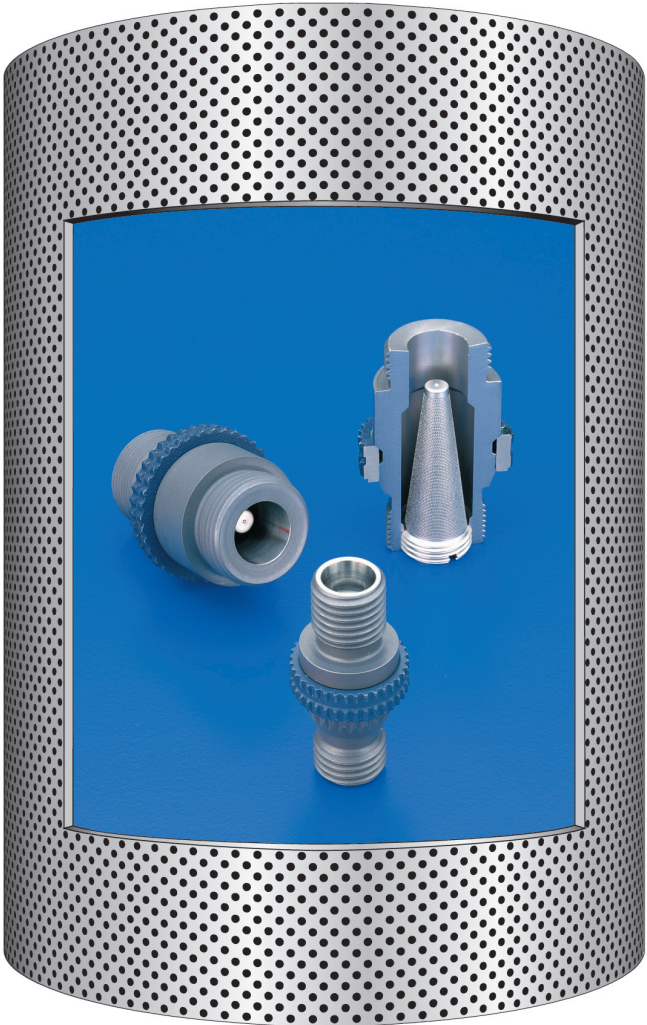

## **HI-BAR SAFETY SCREENS IN RING LOCKED ADAPTERS**

- Specially designed Ring Locked Adapters with integral screens
- 100% proof pressure tested
- 15-5PH stainless steel high strength screen design
- No burst or collapse at 7500 psid fully clogged
- Lightweight titanium adapter
- Dynamic Beam Seal and Flareless Tube ends available

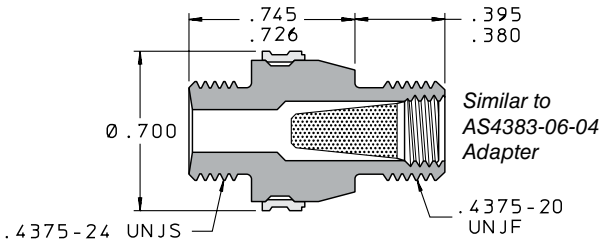

## PERFORMANCE

LEE PART NUMBER	LOHM RATE (nom.)	BURST / COLLAPSE PRESSURE psid (min.)	Rob NUMBER
FSIK0604020A	40	7500	0.6
FSIK0604030A	40	7500	1.6
FSIK0604040A	35	7500	3.5
FSIK0604060A	35	7500	7.6
FSIK0604080A	35	7500	14
FSIK0604100A	35	7500	23
FSIK0604150A	35	7500	90
FSIK0604200A	35	7500	226

## SPECIFICATIONS (nom.)

LEE PART NUMBER	HOLE SIZE in	HOLE SIZE $\mu\text{m}$	OPEN AREA in <sup>2</sup>	TOTAL AREA in <sup>2</sup>	NUMBER OF HOLES
FSIK0604020A	0.002	50	0.02	0.23	7325
FSIK0604030A	0.003	75	0.03	0.23	4230
FSIK0604040A	0.004	100	0.04	0.23	3340
FSIK0604060A	0.006	150	0.04	0.23	1485
FSIK0604080A	0.008	200	0.04	0.23	835
FSIK0604100A	0.010	250	0.04	0.23	510
FSIK0604150A	0.015	380	0.06	0.23	310
FSIK0604200A	0.020	500	0.06	0.23	190

## MATERIALS

PART	MATERIAL	SPECIFICATION	FINISH
Adapter	6AL-4V Ti	AMS 4928, AMS 4965, or AMS 4967	AMS 2488 Type 2 and/or AS5272
Lock Ring	A286 CRES	AMS 5731, AMS 5732, AMS 5734, AMS 5737, or AMS 5853	Passivate
Screen	15-5PH CRES	AMS 5659	Passivate

# HI-BAR Dynamic Beam Seal Safety Screen Adapter

# 117

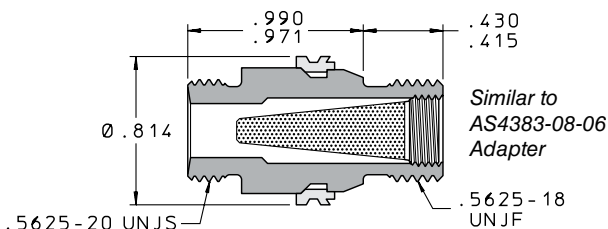

PERFORMANCE			
LEE PART NUMBER	LOHM RATE (nom.)	BURST / COLLAPSE PRESSURE psid (min.)	Rob NUMBER
FSIK0806020A	25	7500	1.6
FSIK0806030A	25	7500	3.5
FSIK0806040A	20	7500	7.8
FSIK0806060A	20	7500	17
FSIK0806080A	20	7500	31
FSIK0806100A	20	7500	51
FSIK0806150A	20	7500	198
FSIK0806200A	20	7500	452

SPECIFICATIONS (nom.)					
LEE PART NUMBER	HOLE SIZE in	HOLE SIZE $\mu\text{m}$	OPEN AREA in <sup>2</sup>	TOTAL AREA in <sup>2</sup>	NUMBER OF HOLES
FSIK0806020A	0.002	50	0.05	0.50	15 925
FSIK0806030A	0.003	75	0.07	0.50	9 195
FSIK0806040A	0.004	100	0.09	0.50	7 320
FSIK0806060A	0.006	150	0.09	0.50	3 255
FSIK0806080A	0.008	200	0.09	0.50	1 830
FSIK0806100A	0.010	250	0.09	0.50	1 145
FSIK0806150A	0.015	380	0.12	0.50	680
FSIK0806200A	0.020	500	0.12	0.50	380

MATERIALS			
PART	MATERIAL	SPECIFICATION	FINISH
Adapter	6AL-4V Ti	AMS 4928, AMS 4965, or AMS 4967	AMS 2488 Type 2 and/ or AS5272
Lock Ring	A286 CRES	AMS 5731, AMS 5732, AMS 5734, AMS 5737, or AMS 5853	Passivate
Screen	15-5PH CRES	AMS 5659	Passivate

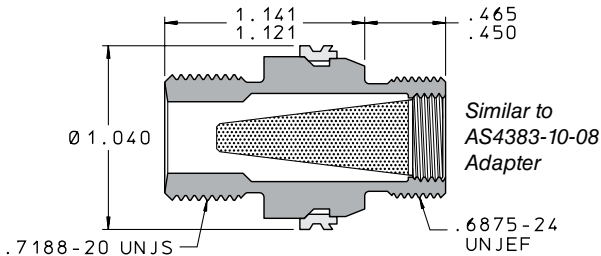

## PERFORMANCE

LEE PART NUMBER	LOHM RATE (nom.)	BURST / COLLAPSE PRESSURE psid (min.)	Rob NUMBER
FSIK1008020A	13	7500	2.7
FSIK1008030A	13	7500	5.9
FSIK1008040A	10	7500	13
FSIK1008060A	10	7500	27
FSIK1008080A	10	7500	50
FSIK1008100A	10	7500	91
FSIK1008150A	10	7500	358
FSIK1008200A	10	7500	770

## SPECIFICATIONS (nom.)

LEE PART NUMBER	HOLE SIZE in	HOLE SIZE $\mu\text{m}$	OPEN AREA in <sup>2</sup>	TOTAL AREA in <sup>2</sup>	NUMBER OF HOLES
FSIK1008020A	0.002	50	0.09	0.90	28 650
FSIK1008030A	0.003	75	0.12	0.90	16 550
FSIK1008040A	0.004	100	0.16	0.90	12 730
FSIK1008060A	0.006	150	0.16	0.90	5 660
FSIK1008080A	0.008	200	0.16	0.90	3 185
FSIK1008100A	0.010	250	0.16	0.90	2 035
FSIK1008150A	0.015	380	0.22	0.90	1 245
FSIK1008200A	0.020	500	0.22	0.90	700

## MATERIALS

PART	MATERIAL	SPECIFICATION	FINISH
Adapter	6AL-4V Ti	AMS 4928, AMS 4965, or AMS 4967	AMS 2488 Type 2 and/or AS5272
Lock Ring	A286 CRES	AMS 5731, AMS 5732, AMS 5734, AMS 5737, or AMS 5853	Passivate
Screen	15-5PH CRES	AMS 5659	Passivate

# HI-BAR Dynamic Beam Seal Safety Screen Adapter

# 119

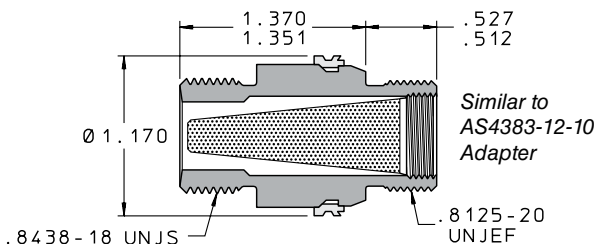

PERFORMANCE			
LEE PART NUMBER	LOHM RATE (nom.)	BURST / COLLAPSE PRESSURE psid (min.)	ROB NUMBER
FSIK1210020A	9	7500	4.7
FSIK1210030A	9	7500	9.8
FSIK1210040A	8	7500	24
FSIK1210060A	8	7500	50
FSIK1210080A	8	7500	93
FSIK1210100A	8	7500	160
FSIK1210150A	8	7500	596
FSIK1210200A	8	7500	1363

SPECIFICATIONS (nom.)					
LEE PART NUMBER	HOLE SIZE in	HOLE SIZE µm	OPEN AREA in <sup>2</sup>	TOTAL AREA in <sup>2</sup>	NUMBER OF HOLES
FSIK1210020A	0.002	50	0.15	1.51	48 090
FSIK1210030A	0.003	75	0.19	1.51	27 730
FSIK1210040A	0.004	100	0.28	1.51	22 280
FSIK1210060A	0.006	150	0.28	1.51	9 825
FSIK1210080A	0.008	200	0.28	1.51	5 525
FSIK1210100A	0.010	250	0.28	1.51	3 565
FSIK1210150A	0.015	380	0.36	1.51	2 050
FSIK1210200A	0.020	500	0.36	1.51	1 145

MATERIALS			
PART	MATERIAL	SPECIFICATION	FINISH
Adapter	6AL-4V Ti	AMS 4928, AMS 4965, or AMS 4967	AMS 2488 Type 2 and/ or AS5272
Lock Ring	A286 CRES	AMS 5731, AMS 5732, AMS 5734, AMS 5737, or AMS 5853	Passivate
Screen	15-5PH CRES	AMS 5659	Passivate

# HI-BAR 4k Flareless Tube Safety Screen Adapter

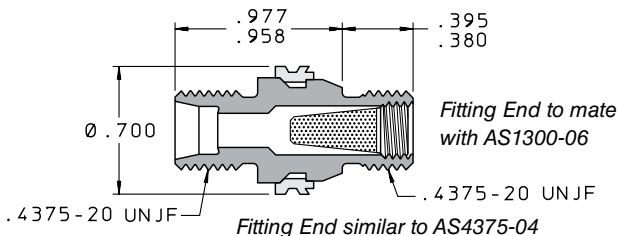

## PERFORMANCE

LEE PART NUMBER	LOHM RATE (nom.)	BURST / COLLAPSE PRESSURE psid (min.)	Rob NUMBER
FSIL0604020A	40	7500	0.6
FSIL0604030A	40	7500	1.6
FSIL0604040A	35	7500	3.5
FSIL0604060A	35	7500	7.6
FSIL0604080A	35	7500	14
FSIL0604100A	35	7500	23
FSIL0604150A	35	7500	90
FSIL0604200A	35	7500	226

## SPECIFICATIONS (nom.)

LEE PART NUMBER	HOLE SIZE in	HOLE SIZE $\mu\text{m}$	OPEN AREA in <sup>2</sup>	TOTAL AREA in <sup>2</sup>	NUMBER OF HOLES
FSIL0604020A	0.002	50	0.02	0.23	7325
FSIL0604030A	0.003	75	0.03	0.23	4230
FSIL0604040A	0.004	100	0.04	0.23	3340
FSIL0604060A	0.006	150	0.04	0.23	1485
FSIL0604080A	0.008	200	0.04	0.23	835
FSIL0604100A	0.010	250	0.04	0.23	510
FSIL0604150A	0.015	380	0.06	0.23	310
FSIL0604200A	0.020	500	0.06	0.23	190

## MATERIALS

PART	MATERIAL	SPECIFICATION	FINISH
Adapter	6AL-4V Ti	AMS 4928, AMS 4965, or AMS 4967	AMS 2488 Type 2 and/or AS5272
Lock Ring	A286 CRES	AMS 5731, AMS 5732, AMS 5734, AMS 5737, or AMS 5853	Passivate
Screen	15-5PH CRES	AMS 5659	Passivate

# HI-BAR 4k Flareless Tube Safety Screen Adapter

# 121

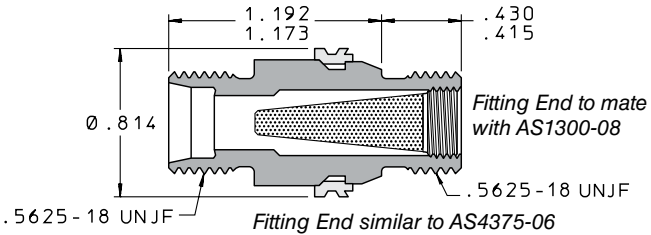

PERFORMANCE			
LEE PART NUMBER	LOHM RATE (nom.)	BURST / COLLAPSE PRESSURE psid (min.)	Rob NUMBER
FSIL0806020A	25	7500	1.6
FSIL0806030A	25	7500	3.4
FSIL0806040A	20	7500	7.8
FSIL0806060A	20	7500	17
FSIL0806080A	20	7500	31
FSIL0806100A	20	7500	51
FSIL0806150A	20	7500	198
FSIL0806200A	20	7500	452

SPECIFICATIONS (nom.)					
LEE PART NUMBER	HOLE SIZE in	HOLE SIZE $\mu\text{m}$	OPEN AREA in <sup>2</sup>	TOTAL AREA in <sup>2</sup>	NUMBER OF HOLES
FSIL0806020A	0.002	50	0.05	0.50	15 925
FSIL0806030A	0.003	75	0.07	0.50	9 195
FSIL0806040A	0.004	100	0.09	0.50	7 320
FSIL0806060A	0.006	150	0.09	0.50	3 255
FSIL0806080A	0.008	200	0.09	0.50	1 830
FSIL0806100A	0.010	250	0.09	0.50	1 145
FSIL0806150A	0.015	380	0.12	0.50	680
FSIL0806200A	0.020	500	0.12	0.50	380

MATERIALS			
PART	MATERIAL	SPECIFICATION	FINISH
Adapter	6AL-4V Ti	AMS 4928, AMS 4965, or AMS 4967	AMS 2488 Type 2 and/or AS5272
Lock Ring	A286 CRES	AMS 5731, AMS 5732, AMS 5734, AMS 5737, or AMS 5853	Passivate
Screen	15-5PH CRES	AMS 5659	Passivate

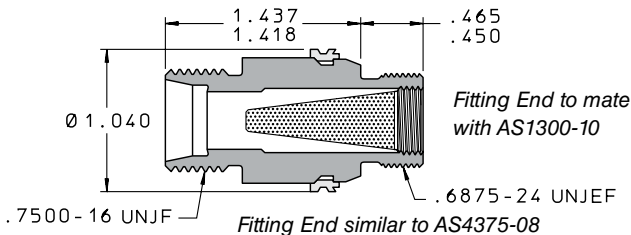

## PERFORMANCE

LEE PART NUMBER	LOHM RATE (nom.)	BURST / COLLAPSE PRESSURE psid (min.)	Rob NUMBER
FSIL1008020A	13	7500	2.7
FSIL1008030A	13	7500	5.9
FSIL1008040A	10	7500	13
FSIL1008060A	10	7500	27
FSIL1008080A	10	7500	50
FSIL1008100A	10	7500	91
FSIL1008150A	10	7500	358
FSIL1008200A	10	7500	770

## SPECIFICATIONS (nom.)

LEE PART NUMBER	HOLE SIZE in	HOLE SIZE $\mu\text{m}$	OPEN AREA in <sup>2</sup>	TOTAL AREA in <sup>2</sup>	NUMBER OF HOLES
FSIL1008020A	0.002	50	0.09	0.90	28 650
FSIL1008030A	0.003	75	0.12	0.90	16 550
FSIL1008040A	0.004	100	0.16	0.90	12 730
FSIL1008060A	0.006	150	0.16	0.90	5 660
FSIL1008080A	0.008	200	0.16	0.90	3 185
FSIL1008100A	0.010	250	0.16	0.90	2 035
FSIL1008150A	0.015	380	0.22	0.90	1 245
FSIL1008200A	0.020	500	0.22	0.90	700

## MATERIALS

PART	MATERIAL	SPECIFICATION	FINISH
Adapter	6AL-4V Ti	AMS 4928, AMS 4965, or AMS 4967	AMS 2488 Type 2 and/or AS5272
Lock Ring	A286 CRES	AMS 5731, AMS 5732, AMS 5734, AMS 5737, or AMS 5853	Passivate
Screen	15-5PH CRES	AMS 5659	Passivate

# HI-BAR 4k Flareless Tube Safety Screen Adapter

# 123

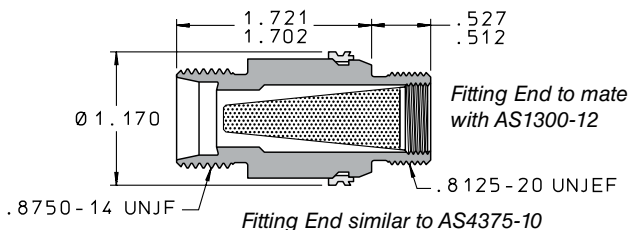

PERFORMANCE			
LEE PART NUMBER	LOHM RATE (nom.)	BURST / COLLAPSE PRESSURE psid (min.)	ROB NUMBER
FSIL1210020A	9	7500	4.7
FSIL1210030A	9	7500	9.8
FSIL1210040A	8	7500	24
FSIL1210060A	8	7500	50
FSIL1210080A	8	7500	93
FSIL1210100A	8	7500	160
FSIL1210150A	8	7500	596
FSIL1210200A	8	7500	1363

SPECIFICATIONS (nom.)					
LEE PART NUMBER	HOLE SIZE in	HOLE SIZE $\mu\text{m}$	OPEN AREA in <sup>2</sup>	TOTAL AREA in <sup>2</sup>	NUMBER OF HOLES
FSIL1210020A	0.002	50	0.15	1.51	48 090
FSIL1210030A	0.003	75	0.19	1.51	27 730
FSIL1210040A	0.004	100	0.28	1.51	22 280
FSIL1210060A	0.006	150	0.28	1.51	9 825
FSIL1210080A	0.008	200	0.28	1.51	5 525
FSIL1210100A	0.010	250	0.28	1.51	3 565
FSIL1210150A	0.015	380	0.36	1.51	2 050
FSIL1210200A	0.020	500	0.36	1.51	1 145

MATERIALS			
PART	MATERIAL	SPECIFICATION	FINISH
Adapter	6AL-4V Ti	AMS 4928, AMS 4965, or AMS 4967	AMS 2488 Type 2 and/or AS5272
Lock Ring	A286 CRES	AMS 5731, AMS 5732, AMS 5734, AMS 5737, or AMS 5853	Passivate
Screen	15-5PH CRES	AMS 5659	Passivate

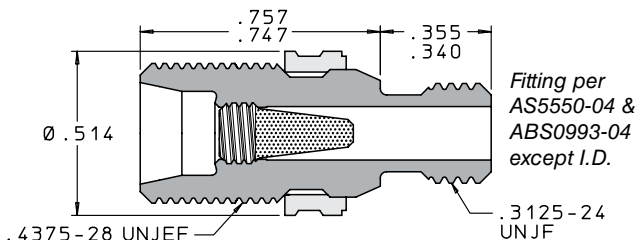

## PERFORMANCE

LEE PART NUMBER	LOHM RATE (nom.)	BURST / COLLAPSE PRESSURE psid (min.)	Rob NUMBER
FSIP0404020A	95	7500	0.3
FSIP0404030A	95	7500	0.7
FSIP0404040A	85	7500	1.4
FSIP0404060A	85	7500	3.0
FSIP0404080A	85	7500	5.7
FSIP0404100A	85	7500	10
FSIP0404150A	85	7500	39
FSIP0404200A	85	7500	83

## SPECIFICATIONS (nom.)

LEE PART NUMBER	HOLE SIZE in	HOLE SIZE $\mu\text{m}$	OPEN AREA in <sup>2</sup>	TOTAL AREA in <sup>2</sup>	NUMBER OF HOLES
FSIP0404020A	0.002	50	0.010	0.10	3185
FSIP0404030A	0.003	75	0.013	0.10	1840
FSIP0404040A	0.004	100	0.018	0.10	1430
FSIP0404060A	0.006	150	0.018	0.10	635
FSIP0404080A	0.008	200	0.018	0.10	360
FSIP0404100A	0.010	250	0.018	0.10	230
FSIP0404150A	0.015	380	0.024	0.10	135
FSIP0404200A	0.020	500	0.024	0.10	75

## MATERIALS

PART	MATERIAL	SPECIFICATION	FINISH
Adapter	6AL-4V Ti	AMS 4928, AMS 4965, or AMS 4967	AMS 2488 Type 2
Lock Ring	A286 CRES	AMS 5731, AMS 5732, AMS 5734, AMS 5737, or AMS 5853	Passivate
Screen	15-5PH CRES	AMS 5659	Passivate

# HI-BAR 5k Flareless Tube Safety Screen Adapter

# 125

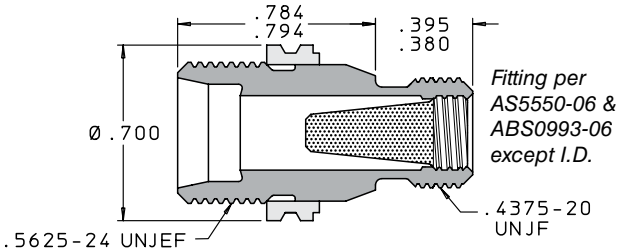

## PERFORMANCE

LEE PART NUMBER	LOHM RATE (nom.)	BURST / COLLAPSE PRESSURE psid (min.)	Rob NUMBER
FSIP0606020A	40	7500	0.6
FSIP0606030A	40	7500	1.6
FSIP0606040A	35	7500	3.5
FSIP0606060A	35	7500	7.6
FSIP0606080A	35	7500	14
FSIP0606100A	35	7500	23
FSIP0606150A	35	7500	90
FSIP0606200A	35	7500	226

## SPECIFICATIONS (nom.)

LEE PART NUMBER	HOLE SIZE in	HOLE SIZE $\mu\text{m}$	OPEN AREA in <sup>2</sup>	TOTAL AREA in <sup>2</sup>	NUMBER OF HOLES
FSIP0606020A	0.002	50	0.02	0.23	7325
FSIP0606030A	0.003	75	0.03	0.23	4230
FSIP0606040A	0.004	100	0.04	0.23	3340
FSIP0606060A	0.006	150	0.04	0.23	1485
FSIP0606080A	0.008	200	0.04	0.23	835
FSIP0606100A	0.010	250	0.04	0.23	510
FSIP0606150A	0.015	380	0.06	0.23	310
FSIP0606200A	0.020	500	0.06	0.23	190

## MATERIALS

PART	MATERIAL	SPECIFICATION	FINISH
Adapter	6AL-4V Ti	AMS 4928, AMS 4965, or AMS 4967	AMS 2488 Type 2
Lock Ring	A286 CRES	AMS 5731, AMS 5732, AMS 5734, AMS 5737, or AMS 5853	Passivate
Screen	15-5PH CRES	AMS 5659	Passivate

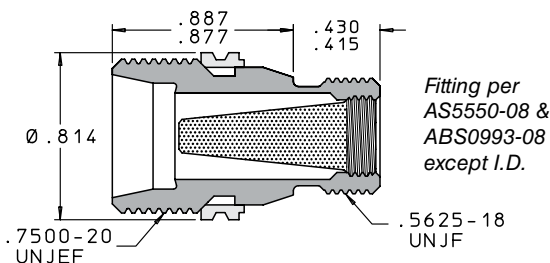

## PERFORMANCE

LEE PART NUMBER	LOHM RATE (nom.)	BURST / COLLAPSE PRESSURE psid (min.)	ROB NUMBER
FSIP0808020A	25	7500	1.6
FSIP0808030A	25	7500	3.7
FSIP0808040A	20	7500	8
FSIP0808060A	20	7500	17
FSIP0808080A	20	7500	31
FSIP0808100A	20	7500	57
FSIP0808150A	20	7500	211
FSIP0808200A	20	7500	457

## SPECIFICATIONS (nom.)

LEE PART NUMBER	HOLE SIZE in	HOLE SIZE $\mu\text{m}$	OPEN AREA in <sup>2</sup>	TOTAL AREA in <sup>2</sup>	NUMBER OF HOLES
FSIP0808020A	0.002	50	0.06	0.56	17825
FSIP0808030A	0.003	75	0.07	0.56	10330
FSIP0808040A	0.004	100	0.10	0.56	7960
FSIP0808060A	0.006	150	0.10	0.56	3535
FSIP0808080A	0.008	200	0.10	0.56	1990
FSIP0808100A	0.010	250	0.10	0.56	1270
FSIP0808150A	0.015	380	0.13	0.56	735
FSIP0808200A	0.020	500	0.13	0.56	415

## MATERIALS

PART	MATERIAL	SPECIFICATION	FINISH
Adapter	6AL-4V Ti	AMS 4928, AMS 4965, or AMS 4967	AMS 2488 Type 2
Lock Ring	A286 CRES	AMS 5731, AMS 5732, AMS 5734, AMS 5737, or AMS 5853	Passivate
Screen	15-5PH CRES	AMS 5659	Passivate

# HI-BAR 5K Flareless Tube Safety Screen Adapter

# 127

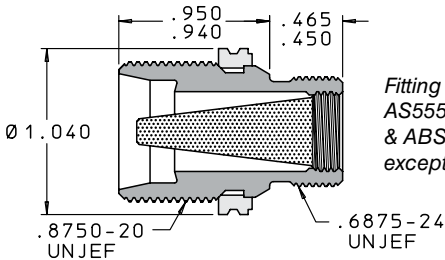

Fitting per  
AS5550-10  
& ABS0993-10  
except I.D.

PERFORMANCE			
LEE PART NUMBER	LOHM RATE (nom.)	BURST / COLLAPSE PRESSURE psid (min.)	ROB NUMBER
FSIP1010020A	13	7500	2.7
FSIP1010030A	13	7500	5.9
FSIP1010040A	10	7500	13
FSIP1010060A	10	7500	27
FSIP1010080A	10	7500	50
FSIP1010100A	10	7500	91
FSIP1010150A	10	7500	358
FSIP1010200A	10	7500	770

SPECIFICATIONS (nom.)					
LEE PART NUMBER	HOLE SIZE in	HOLE SIZE $\mu\text{m}$	OPEN AREA in <sup>2</sup>	TOTAL AREA in <sup>2</sup>	NUMBER OF HOLES
FSIP1010020A	0.002	50	0.09	0.90	28650
FSIP1010030A	0.003	75	0.12	0.90	16550
FSIP1010040A	0.004	100	0.16	0.90	12730
FSIP1010060A	0.006	150	0.16	0.90	5660
FSIP1010080A	0.008	200	0.16	0.90	3185
FSIP1010100A	0.010	250	0.16	0.90	2035
FSIP1010150A	0.015	380	0.22	0.90	1245
FSIP1010200A	0.020	500	0.22	0.90	700

MATERIALS			
PART	MATERIAL	SPECIFICATION	FINISH
Adapter	6AL-4V Ti	AMS 4928, AMS 4965, or AMS 4967	AMS 2488 Type 2
Lock Ring	A286 CRES	AMS 5731, AMS 5732, AMS 5734, AMS 5737, or AMS 5853	Passivate
Screen	15-5PH CRES	AMS 5659	Passivate

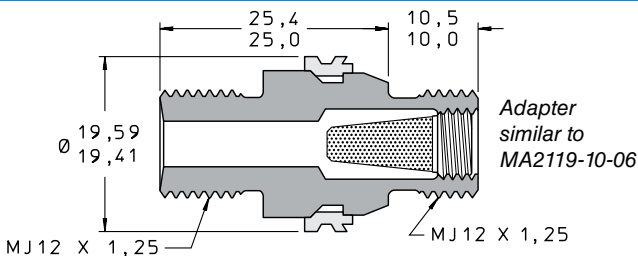

## PERFORMANCE

LEE PART NUMBER	LOHM RATE (nom.)	BURST / COLLAPSE PRESSURE bar (min.)	Rob NUMBER
FSIJ1206020A	40	520	0.6
FSIJ1206030A	40	520	1.6
FSIJ1206040A	35	520	3.5
FSIJ1206060A	35	520	7.6
FSIJ1206080A	35	520	14
FSIJ1206100A	35	520	23
FSIJ1206150A	35	520	90
FSIJ1206200A	35	520	226

## SPECIFICATIONS (nom.)

LEE PART NUMBER	HOLE SIZE in	HOLE SIZE $\mu\text{m}$	OPEN AREA $\text{mm}^2$	TOTAL AREA $\text{mm}^2$	NUMBER OF HOLES
FSIJ1206020A	0.002	50	13	148	7325
FSIJ1206030A	0.003	75	20	148	4230
FSIJ1206040A	0.004	100	27	148	3340
FSIJ1206060A	0.006	150	27	148	1485
FSIJ1206080A	0.008	200	27	148	835
FSIJ1206100A	0.010	250	27	148	510
FSIJ1206150A	0.015	380	35	148	310
FSIJ1206200A	0.020	500	35	148	190

## MATERIALS

PART	MATERIAL	SPECIFICATION	FINISH
Adapter	6AL-4V Ti	AMS 4928, AMS 4965, or AMS 4967	AMS 2488 Type 2 and/or AS5272
Lock Ring	A286 CRES	AMS 5731, AMS 5732, AMS 5734, AMS 5737, or AMS 5853	Passivate
Screen	15-5PH CRES	AMS 5659	Passivate

# HI-BAR Metric Dynamic Beam Seal Safety Screen Adapter

# 129

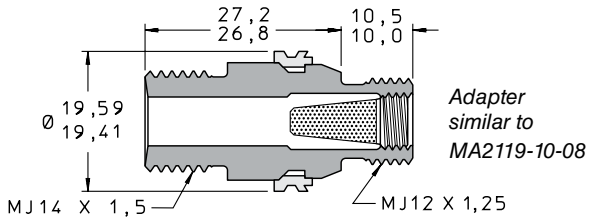

## PERFORMANCE

LEE PART NUMBER	LOHM RATE (nom.)	BURST / COLLAPSE PRESSURE bar (min.)	Rob NUMBER
FSIJ1208020A	40	520	0.6
FSIJ1208030A	40	520	1.6
FSIJ1208040A	35	520	3.5
FSIJ1208060A	35	520	7.6
FSIJ1208080A	35	520	14
FSIJ1208100A	35	520	23
FSIJ1208150A	35	520	90
FSIJ1208200A	35	520	226

## SPECIFICATIONS (nom.)

LEE PART NUMBER	HOLE SIZE in	HOLE SIZE $\mu\text{m}$	OPEN AREA $\text{mm}^2$	TOTAL AREA $\text{mm}^2$	NUMBER OF HOLES
FSIJ1208020A	0.002	50	13	148	7325
FSIJ1208030A	0.003	75	20	148	4230
FSIJ1208040A	0.004	100	27	148	3340
FSIJ1208060A	0.006	150	27	148	1485
FSIJ1208080A	0.008	200	27	148	835
FSIJ1208100A	0.010	250	27	148	510
FSIJ1208150A	0.015	380	35	148	310
FSIJ1208200A	0.020	500	35	148	190

## MATERIALS

PART	MATERIAL	SPECIFICATION	FINISH
Adapter	6AL-4V Ti	AMS 4928, AMS 4965, or AMS 4967	AMS 2488 Type 2 and/ or AS5272
Lock Ring	A286 CRES	AMS 5731, AMS 5732, AMS 5734, AMS 5737, or AMS 5853	Passivate
Screen	15-5PH CRES	AMS 5659	Passivate

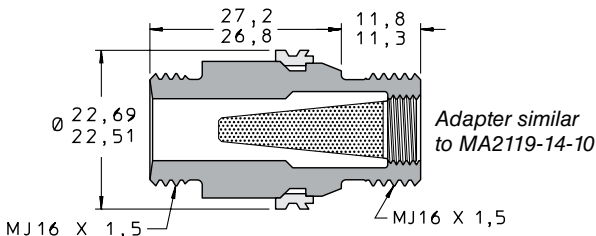

PERFORMANCE			
LEE PART NUMBER	LOHM RATE (nom.)	BURST / COLLAPSE PRESSURE bar (min.)	Rob NUMBER
FSIJ1610020A	25	520	1.6
FSIJ1610030A	25	520	3.4
FSIJ1610040A	20	520	7.8
FSIJ1610060A	20	520	17
FSIJ1610080A	20	520	31
FSIJ1610100A	20	520	51
FSIJ1610150A	20	520	198
FSIJ1610200A	20	520	452

SPECIFICATIONS (nom.)					
LEE PART NUMBER	HOLE SIZE in	HOLE SIZE $\mu\text{m}$	OPEN AREA $\text{mm}^2$	TOTAL AREA $\text{mm}^2$	NUMBER OF HOLES
FSIJ1610020A	0.002	50	32	322	15 925
FSIJ1610030A	0.003	75	42	322	9 195
FSIJ1610040A	0.004	100	58	322	7 320
FSIJ1610060A	0.006	150	58	322	3 255
FSIJ1610080A	0.008	200	58	322	1 830
FSIJ1610100A	0.010	250	58	322	1 145
FSIJ1610150A	0.015	380	77	322	680
FSIJ1610200A	0.020	500	77	322	380

MATERIALS			
PART	MATERIAL	SPECIFICATION	FINISH
Adapter	6AL-4V Ti	AMS 4928, AMS 4965, or AMS 4967	AMS 2488 Type 2 and/or AS5272
Lock Ring	A286 CRES	AMS 5731, AMS 5732, AMS 5734, AMS 5737, or AMS 5853	Passivate
Screen	15-5PH CRES	AMS 5659	Passivate

# HI-BAR Metric Dynamic Beam Seal Safety Screen Adapter

# 131

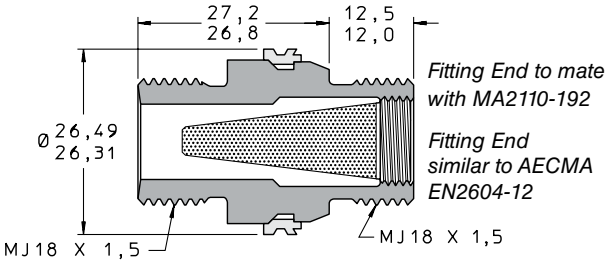

## PERFORMANCE

LEE PART NUMBER	LOHM RATE (nom.)	BURST / COLLAPSE PRESSURE bar (min.)	Rob NUMBER
FSIJ1812020A	13	520	2.7
FSIJ1812030A	13	520	5.9
FSIJ1812040A	10	520	13
FSIJ1812060A	10	520	27
FSIJ1812080A	10	520	50
FSIJ1812100A	10	520	91
FSIJ1812150A	10	520	358
FSIJ1812200A	10	520	770

## SPECIFICATIONS (nom.)

LEE PART NUMBER	HOLE SIZE in	HOLE SIZE $\mu\text{m}$	OPEN AREA $\text{mm}^2$	TOTAL AREA $\text{mm}^2$	NUMBER OF HOLES
FSIJ1812020A	0.002	50	58	581	28 650
FSIJ1812030A	0.003	75	77	581	16 550
FSIJ1812040A	0.004	100	103	581	12 730
FSIJ1812060A	0.006	150	103	581	5 660
FSIJ1812080A	0.008	200	103	581	3 185
FSIJ1812100A	0.010	250	103	581	2 035
FSIJ1812150A	0.015	380	142	581	1 245
FSIJ1812200A	0.020	500	142	581	700

## MATERIALS

PART	MATERIAL	SPECIFICATION	FINISH
Adapter	6AL-4V Ti	AMS 4928, AMS 4965, or AMS 4967	AMS 2488 Type 2 and/ or AS5272
Lock Ring	A286 CRES	AMS 5731, AMS 5732, AMS 5734, AMS 5737, or AMS 5853	Passivate
Screen	15-5PH CRES	AMS 5659	Passivate

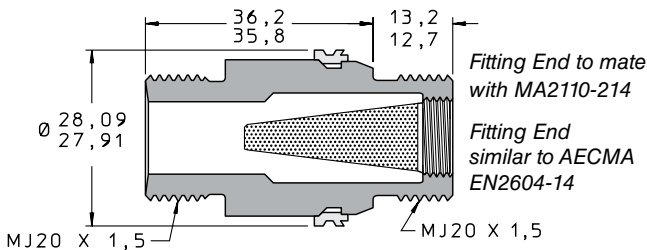

## PERFORMANCE

LEE PART NUMBER	LOHM RATE (nom.)	BURST / COLLAPSE PRESSURE bar (min.)	Rob NUMBER
FSIJ2014020A	13	520	2.7
FSIJ2014030A	13	520	5.9
FSIJ2014040A	10	520	13
FSIJ2014060A	10	520	21
FSIJ2014080A	10	520	50
FSIJ2014100A	10	520	91
FSIJ2014150A	10	520	358
FSIJ2014200A	10	520	770

## SPECIFICATIONS (nom.)

LEE PART NUMBER	HOLE SIZE in	HOLE SIZE $\mu$ m	OPEN AREA mm <sup>2</sup>	TOTAL AREA mm <sup>2</sup>	NUMBER OF HOLES
FSIJ2014020A	0.002	50	58	581	28 650
FSIJ2014030A	0.003	75	77	581	16 550
FSIJ2014040A	0.004	100	103	581	12 730
FSIJ2014060A	0.006	150	103	581	5 660
FSIJ2014080A	0.008	200	103	581	3 185
FSIJ2014100A	0.010	250	103	581	2 035
FSIJ2014150A	0.015	380	142	581	1 245
FSIJ2014200A	0.020	500	142	581	700

## MATERIALS

PART	MATERIAL	SPECIFICATION	FINISH
Adapter	6AL-4V Ti	AMS 4928, AMS 4965, or AMS 4967	AMS 2488 Type 2 and/ or AS5272
Lock Ring	A286 CRES	AMS 5731, AMS 5732, AMS 5734, AMS 5737, or AMS 5853	Passivate
Screen	15-5PH CRES	AMS 5659	Passivate

# HI-BAR Metric Dynamic Beam Seal Safety Screen Adapter

# 133

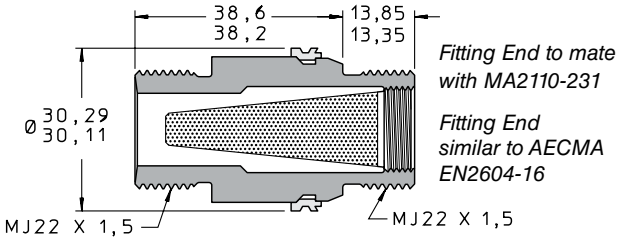

## PERFORMANCE

LEE PART NUMBER	LOHM RATE (nom.)	BURST / COLLAPSE PRESSURE bar (min.)	Rob NUMBER
FSIJ2216020A	9	520	4.7
FSIJ2216030A	9	520	9.8
FSIJ2216040A	8	520	24
FSIJ2216060A	8	520	50
FSIJ2216080A	8	520	93
FSIJ2216100A	8	520	160
FSIJ2216150A	8	520	596
FSIJ2216200A	8	520	1363

## SPECIFICATIONS (nom.)

LEE PART NUMBER	HOLE SIZE in	HOLE SIZE $\mu\text{m}$	OPEN AREA $\text{mm}^2$	TOTAL AREA $\text{mm}^2$	NUMBER OF HOLES
FSIJ2216020A	0.002	50	97	974	48 090
FSIJ2216030A	0.003	75	122	974	27 730
FSIJ2216040A	0.004	100	180	974	22 280
FSIJ2216060A	0.006	150	180	974	9 825
FSIJ2216080A	0.008	200	180	974	5 525
FSIJ2216100A	0.010	250	180	974	3 565
FSIJ2216150A	0.015	380	232	974	2 050
FSIJ2216200A	0.020	500	232	974	1 145

## MATERIALS

PART	MATERIAL	SPECIFICATION	FINISH
Adapter	6AL-4V Ti	AMS 4928, AMS 4965, or AMS 4967	AMS 2488 Type 2 and/or AS5272
Lock Ring	A286 CRES	AMS 5731, AMS 5732, AMS 5734, AMS 5737, or AMS 5853	Passivate
Screen	15-5PH CRES	AMS 5659	Passivate

## HI-BAR INLET SAFETY SCREENS

- AS Flareless tube to port adapter with integral screen
- 100% proof pressure tested
- No burst or collapse at 6000 psid fully clogged
- Hole sizes from 0.002" to 0.020"
- Available in -4, -6, -8 and -10 configurations
- Minimizes space and weight

# HI-BAR Inlet Safety Screen 135

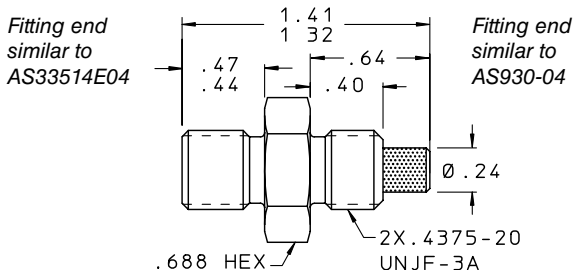

PERFORMANCE			
LEE PART NUMBER	LOHM RATE (nom.)	BURST / COLLAPSE PRESSURE psid (min.)	ROB NUMBER
FSIA0404020A	55	6000	0.9
FSIA0404030A	40	6000	2.3
FSIA0404040A	30	6000	4.3
FSIA0404060A	30	6000	9.3
FSIA0404080A	30	6000	17.3
FSIA0404100A	30	6000	29.8
FSIA0404150A	30	6000	115
FSIA0404200A	30	6000	260

SPECIFICATIONS (nom.)					
LEE PART NUMBER	HOLE SIZE in	HOLE SIZE $\mu\text{m}$	OPEN AREA in <sup>2</sup>	TOTAL AREA in <sup>2</sup>	NUMBER OF HOLES
FSIA0404020A	0.002	50	0.03	0.29	8220
FSIA0404030A	0.003	75	0.04	0.29	6045
FSIA0404040A	0.004	100	0.05	0.29	4080
FSIA0404060A	0.006	150	0.05	0.29	1810
FSIA0404080A	0.008	200	0.05	0.29	1020
FSIA0404100A	0.010	250	0.05	0.29	660
FSIA0404150A	0.015	380	0.07	0.29	390
FSIA0404200A	0.020	500	0.07	0.29	220

MATERIALS			
PART	MATERIAL	SPECIFICATION	FINISH
Adapter	15-5PH CRES	AMS 5659	Passivate
Screen	15-5PH CRES	AMS 5659	Passivate
Braze	Silver Alloy	AMS 4774	—

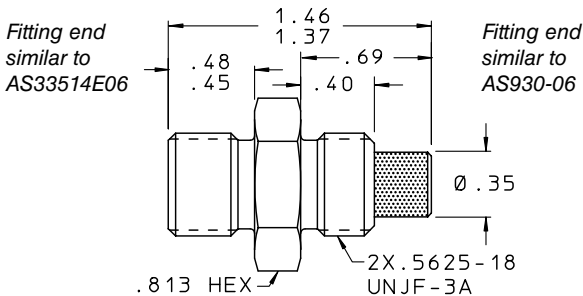

### PERFORMANCE

LEE PART NUMBER	LOHM RATE (nom.)	BURST / COLLAPSE PRESSURE psid (min.)	Rob NUMBER
FSIA0606020A	25	6000	1.7
FSIA0606030A	17	6000	4.0
FSIA0606040A	14	6000	7.6
FSIA0606060A	14	6000	16.3
FSIA0606080A	14	6000	30.3
FSIA0606100A	14	6000	51.4
FSIA0606150A	12	6000	198
FSIA0606200A	12	6000	460

### SPECIFICATIONS (nom.)

LEE PART NUMBER	HOLE SIZE in	HOLE SIZE $\mu\text{m}$	OPEN AREA in <sup>2</sup>	TOTAL AREA in <sup>2</sup>	NUMBER OF HOLES
FSIA0606020A	0.002	50	0.05	0.52	14 460
FSIA0606030A	0.003	75	0.06	0.46	10 630
FSIA0606040A	0.004	100	0.08	0.46	7 180
FSIA0606060A	0.006	150	0.08	0.46	3 190
FSIA0606080A	0.008	200	0.08	0.46	1 790
FSIA0606100A	0.010	250	0.09	0.52	1 150
FSIA0606150A	0.015	380	0.11	0.46	680
FSIA0606200A	0.020	500	0.11	0.46	390

### MATERIALS

PART	MATERIAL	SPECIFICATION	FINISH
Adapter	15-5PH CRES	AMS 5659	Passivate
Screen	15-5PH CRES	AMS 5659	Passivate
Braze	Silver Alloy	AMS 4774	—

# HI-BAR Inlet Safety Screen 137

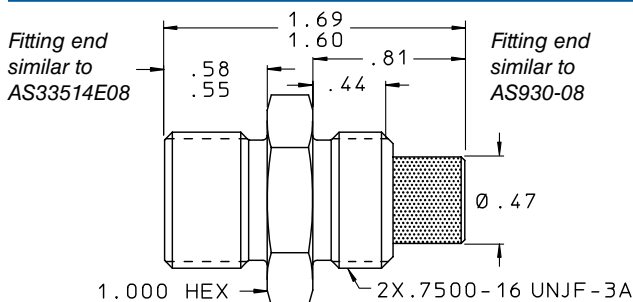

## PERFORMANCE

LEE PART NUMBER	LOHM RATE (nom.)	BURST / COLLAPSE PRESSURE psid (min.)	Rob NUMBER
FSIA0808020A	12	6000	3.4
FSIA0808030A	10	6000	8.3
FSIA0808040A	8	6000	15.8
FSIA0808060A	7	6000	33.9
FSIA0808080A	7	6000	63.1
FSIA0808100A	7	6000	107
FSIA0808150A	7	6000	412
FSIA0808200A	7	6000	948

## SPECIFICATIONS (nom.)

LEE PART NUMBER	HOLE SIZE in	HOLE SIZE $\mu\text{m}$	OPEN AREA in <sup>2</sup>	TOTAL AREA in <sup>2</sup>	NUMBER OF HOLES
FSIA0808020A	0.002	50	0.10	1.08	30 060
FSIA0808030A	0.003	75	0.16	1.08	22 100
FSIA0808040A	0.004	100	0.19	1.08	14 910
FSIA0808060A	0.006	150	0.19	1.08	6 630
FSIA0808080A	0.008	200	0.19	1.08	3 730
FSIA0808100A	0.010	250	0.19	1.08	2 390
FSIA0808150A	0.015	380	0.25	1.08	1 410
FSIA0808200A	0.020	500	0.25	1.08	800

## MATERIALS

PART	MATERIAL	SPECIFICATION	FINISH
Adapter	15-5PH CRES	AMS 5659	Passivate
Screen	15-5PH CRES	AMS 5659	Passivate
Braze	Silver Alloy	AMS 4774	—

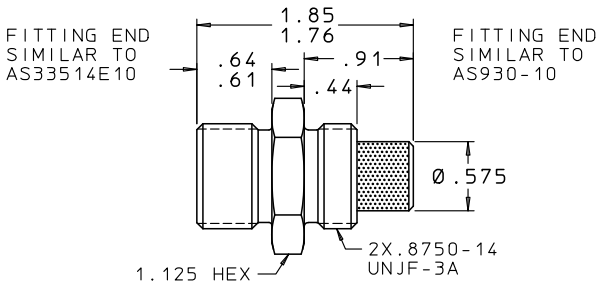

### PERFORMANCE

LEE PART NUMBER	LOHM RATE (nom.)	BURST / COLLAPSE PRESSURE psid (min.)	Rob NUMBER
FSIA1010020A	10	6000	5.1
FSIA1010030A	7	6000	12.3
FSIA1010040A	5	6000	23.5
FSIA1010060A	5	6000	50.3
FSIA1010080A	5	6000	93.6
FSIA1010100A	5	6000	158
FSIA1010150A	5	6000	618
FSIA1010200A	5	6000	1405

### SPECIFICATIONS (nom.)

LEE PART NUMBER	HOLE SIZE in	HOLE SIZE $\mu\text{m}$	OPEN AREA in <sup>2</sup>	TOTAL AREA in <sup>2</sup>	NUMBER OF HOLES
FSIA1010020A	0.002	50	0.15	1.61	44 570
FSIA1010030A	0.003	75	0.23	1.61	32 760
FSIA1010040A	0.004	100	0.28	1.61	22 110
FSIA1010060A	0.006	150	0.28	1.61	9 830
FSIA1010080A	0.008	200	0.28	1.61	5 529
FSIA1010100A	0.010	250	0.28	1.61	3 539
FSIA1010150A	0.015	380	0.37	1.61	2 100
FSIA1010200A	0.020	500	0.37	1.61	1 180

### MATERIALS

PART	MATERIAL	SPECIFICATION	FINISH
Adapter	15-5PH CRES	AMS 5659	Passivate
Screen	15-5PH CRES	AMS 5659	Passivate
Braze	Silver Alloy	AMS 4774	—

## **CUSTOM CAPABILITIES**

The Lee Company is pleased to design any special safety screen product to fill your needs. In fact, over 50 percent of safety screens manufactured by The Lee Company are special products designed to meet the requirements of a specific application. Our capabilities far exceed our standard product line, including, for example, drilled hole sizes between 25 micron and 1500 micron, a wide variety of materials, higher burst and collapse pressure ratings, or unique envelopes optimized for high flow capacity, custom mounting, or integrated bypass mechanisms.



# Piloting Solenoid Valve



- ❑ **Ultra-Compact Design Saves Space and Weight**
- ❑ **Low Power Consumption**
- ❑ **Positive Pull-In At High Temperatures**
- ❑ **Lee MultiSeal® Saves Space, Weight and Machining Costs**
- ❑ **O-Rings and Back-Up Rings are Eliminated with Lee MultiSeal**
- ❑ **Reliable, Low Leakage, Miniature Valve Element**

## TABLE OF CONTENTS

<b>2 and 3-Way Piloting Solenoid Valves</b>	Single and Dual Coil, 3000, 4000 & 5000 psi.....	6 – 13
	Single and Dual Coil, 360° Porting – 3000 psi.....	14 – 17
<b>2 and 3-Way High Flow Solenoid Valves</b>	Single and Dual Coil – 3000 psi.....	18 – 25
<b>Zero Leak Solenoid Valves</b>	Single and Dual Coil – 500 to 3000 psi.....	26 – 29
<b>Latching Solenoid Valves</b>	Single Coil – 3000 psi.....	30 – 33
<b>Performance Racing Solenoid Valves</b>	12V, 360° Porting, Flange Mount – 3000 psi.....	34 – 37
<b>High Speed Solenoid Valves</b>	IEP Series, Miniature, 2-Way.....	38
<b>Custom Capabilities</b>	Customized for particular applications.....	39

Lee Miniature Piloting Solenoid Valves were designed and developed to be the most reliable, efficient, and compact solenoid valves available. The valves have been qualified to numerous aerospace performance and environmental testing standards. They have proven themselves with decades of use in demanding applications under harsh conditions ranging from the high temperatures and pressures of deep subsea oil wells to the cold and vacuum of outer space.

The fluid control components of the solenoid valves are based on proven low-leakage, high reliability designs extensively used in Lee check and shuttle valves and are protected by an integral safety screen. The innovative coil designs have low power consumption, fast response times, and are rated for positive pull in at high temperature and stringent minimum drop out requirements. By using MultiSeal® technology, Lee solenoid valves offer significant space and weight savings with the smallest package weighing less than 0.10 lbs. (1.6 oz.).

## **LEE MULTISEAL®**

The MultiSeal® is a sealing concept based on the controlled expansion of a cylindrical polyamide-imide element, eliminating conventional O-Rings and Anti-Extrusion Rings. The MultiSeal radically simplifies port layout and offers significant space savings, reduced machining costs and higher reliability than traditional sealing methods. To meet the rigorous demands of the aerospace industry, the MultiSeal has completed extensive qualification testing including 10,000,000 impulse cycles (0-7500-0 PSI) at 275°F. The full details have been published in SAE paper #912134 "Total flexibility in Cartridge Valve Porting Through Innovative Sealing Technology".

## STANDARD DESIGNS

Normally closed and normally open, 2 position, 2 and 3-way piloting solenoid valves are offered as standard versions in single and dual coil designs. They are designed for operation in a temperature range of -65°F to 275°F. Most versions utilize a threaded captive retainer for easy installation and extraction and have either lead wires or an integral MIL-DTL-38999 connector. Each of these are available for 3,000 psi, 4,000 psi, or 5,000 psi systems with Lohm rates of 1,800 to 2,800 Lohms. When porting flexibility is required, the unique 360° MultiSeal® provides the ability for omnidirectional porting in a 3,100 Lohm, 3,000 psi configuration.

High flow solenoid valves are also offered in 2 and 3-way versions. Designed for 3,000 psi systems, they have a Lohm rate of 200 and 300 Lohms respectively, and are available in normally open and normally closed configurations.

The Zero Leak Solenoid Valve extends the sealing performance of our field proven piloting solenoid valves. The valve seat incorporates a polymer seal to achieve zero leakage. The standard version of this valve is a pressure assist to close design. This means that a minimum of 500 psid is required to seat the ball and ensure there is no leakage between ports.

The Latching Solenoid Valve is the ideal solution for power sensitive applications. By incorporating permanent magnets into the coil design, this solenoid valve offers a dramatic reduction in overall power consumption, particularly when operating with extended “ON” periods. Unlike traditional designs that require continuous voltage to energize the valve from its natural state, this latching solenoid requires only a momentary pulse of less than a Joule to switch to and remain in state.

The Lee Company also offers two miniature solenoid valves designed to meet unique requirements. The Performance Racing solenoid design combines the flexibility of the 360° MultiSeal, a flange mount interface and a miniature 12V coil to further reduce space, weight, and power consumption. The High Speed Solenoid Valve has a response time below 0.5 ms, and operates at pressures up to 800 psid. It is commonly used to meter flow in applications such as small satellite propulsion systems.

## PRESSURE ASSIST TO OPEN DESIGN

Lee Miniature Piloting Solenoid Valves utilize a pressure assist to open configuration. Operating them at pressures other than their rated pressure may affect performance and cycle life. Cycling the valve in air or 'dry clicking' the valve is not recommended as it may damage the internal components. Custom valves are available for low operating pressure or when a wide operating pressure range is required.

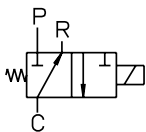

NORMALLY  
CLOSED

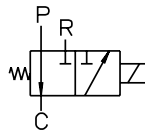

NORMALLY  
OPEN

# 6

# Piloting Solenoid Valve

## SINGLE COIL

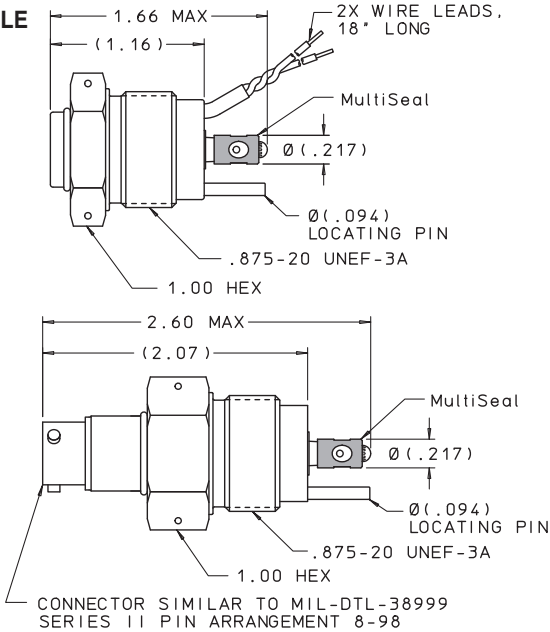

J

LEE PART NUMBER		RATED PRESSURE (psi)	PORTING
NORMALLY CLOSED	NORMALLY OPEN		
SDBB21210*3**	SDBB21210*2**	3000	2-Way
SDBB21310*3**	SDBB21310*2**	3000	3-Way
SDBB21311*3**	SDBB21311*2**	4000	3-Way
SDBB21212*3**	SDBB21212*2**	5000	2-Way
SDBB21312*3**	SDBB21312*2**	5000	3-Way

Operating at Other Pressures May Affect Performance and Cycle Life

Replacement MultiSeal® Part Number.. SDBB2130108A or SDBB2130208A (5000 psi)  
 Recommended Installation Torque..... 25 ft\* lbs nominal  
 Installation Guide ..... PS P1186

\*Test Fluid: 0 = Skydrol, 1 = MIL-PRF-5606, MIL-PRF-83282

\*\* Electrical: A = Lead Wire Front, B = Lead Wire Rear, E = Connector

# Piloting Solenoid Valve

7

## SINGLE COIL

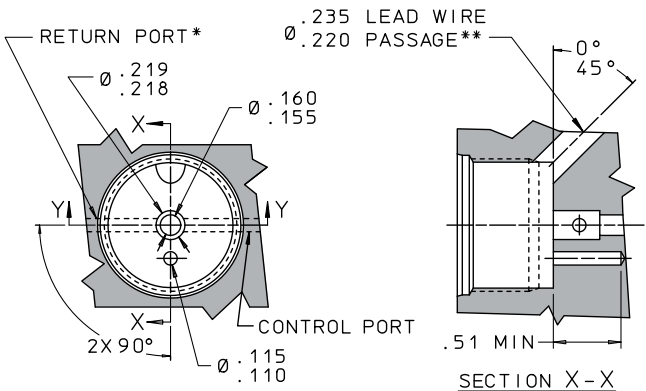
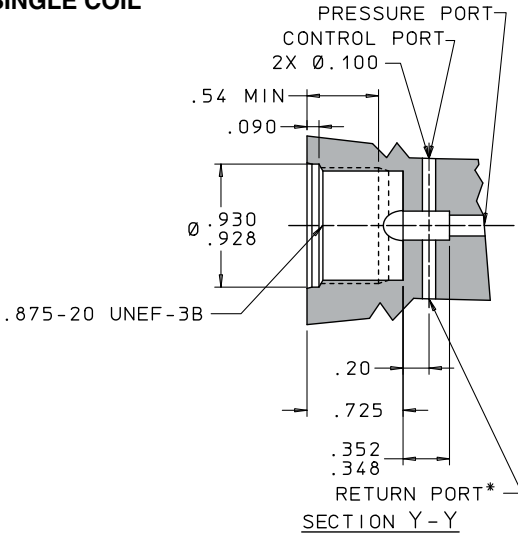

\* 3-Way version only

\*\* Lead wire front version only

J

## 8

## Piloting Solenoid Valve

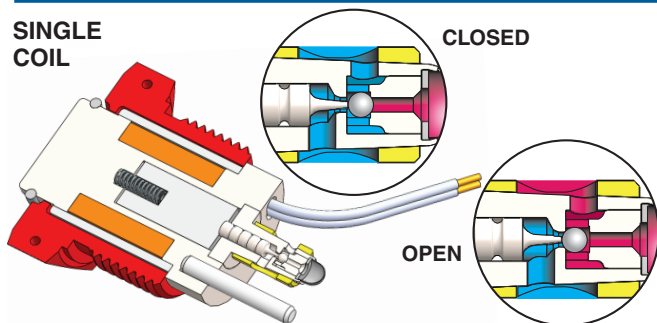
SINGLE  
COIL**MATERIALS**

Body &amp; Ball Seat: 15-5 PH CRES/AMS 5659

MultiSeal®: Polyamide-Imide/AMS 3670

Ball &amp; Pin: 440C CRES/AMS 5630

Spring: 302 CRES/AMS 5688

Flanges, Plungers &amp; Cover: Si Iron BFM/ASTM A867

Filter Screen: 304L CRES/ASTM A666

Shunt: 22-13-5 CRES/AMS 5764

Shims &amp; Spacers: 302 CRES/ASTM A666

Shaft: 440C CRES/AMS-QQ-S-763

Plug &amp; Pushrod: 303 CRES/QQ-S-763C

Retainer: 2024 T-351 AL/AMS-QQ-A-225/6

Retaining Ring: 302 CRES/ASTM A313/A313M

Coil: Copper Magnet Wire/NEMA  
MW1000/MW16

Lead Wire: 22 AWG/SAE AS22759/11

Shrink Tube: AMS-DTL-23053 / 8 &amp; / 12

Insulation Tape: Polyimide/ASTM D5213

Solder: Sb05A/J-STD-006

Brazo: AMS 4774

Potting Compound: Stycast 2762FT, Catalyst 17

Connector: Shell: 304L, Pins: Gold Plated,  
Seal: Fluorosilicone Elastomer

Connector Sleeve: 304 CRES/AMS-QQ-S-763

Connecting Wire: 26 AWG/SAE AS22759/11-26

**FINISH**

CRES Parts: Passivated

Soft Magnetic Material: Nickel Plate/AMS 2404

Retainer: Anodize/MIL-A-8625 Type II

## SINGLE COIL

### OPERATING TEMPERATURE:

Ambient: -65°F to 275°F

Fluid: -65°F to 275°F

### LEAKAGE:

Internal: 1 cc/minute max. at rated pressure

External: 0 cc

### LOHM RATES:

3000 psi rated valve: 1800 Lohms

4000 psi rated valve: 2200 Lohms

5000 psi rated valve: 2800 Lohms

Operating at other pressures may affect performance and cycle life

### ELECTRICAL:

Current Drain: 0.28 amps at 28 Vdc at 70°F (7.8 Watts)

Max. Operating Voltage: 32.2 Vdc

Pull In Voltage: 18 Vdc max. at 275°F and rated pressure

Drop Out Voltage: 3.0 Vdc min. at 70°F and rated pressure

Resistance: 92-108 Ohms at 70°F

Response Time:

Pull In: (28 Vdc at 70°F and rated pressure)

0.015 seconds max., normally closed version

0.040 seconds max., normally open version

Drop Out: (28 Vdc at 70°F and rated pressure)

0.015 seconds max., normally open version

0.035 seconds max., normally closed version

Stabilization Temperature: 225°F max. with 28 Vdc applied, suspended in 70°F to 110°F still air, continuously energized

Insulation Resistance: 100 Megohms min. with 500 Vdc applied for 60 seconds

Dielectric Strength: 1500 Vrms min. at 60 Hz for 60 seconds

### SCREEN HOLE SIZE:

.004 inches nominal

### WEIGHT:

.14 lbs. max. lead wire style

.17 lbs. max. connector style

# 10

# Piloting Solenoid Valve

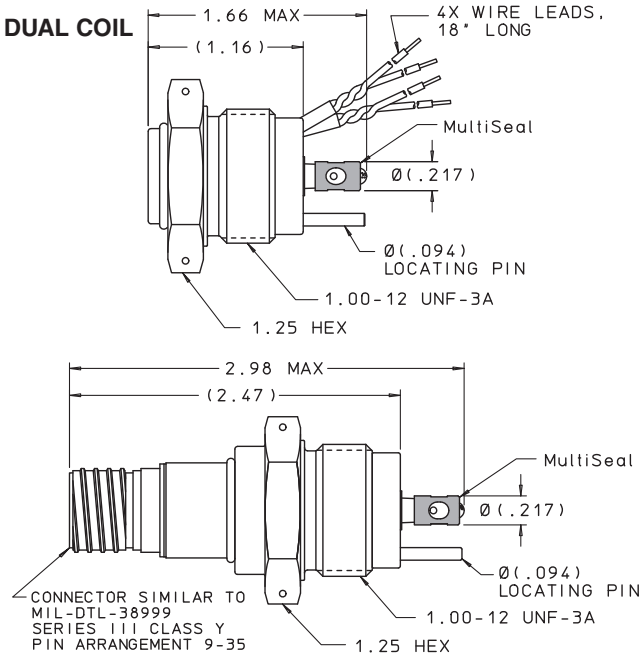

J	LEE PART NUMBER		RATED PRESSURE (psi)	PORTING
	NORMALLY CLOSED	NORMALLY OPEN		
	SDBB21220*3**	SDBB21220*2**	3000	2-Way
	SDBB21320*3**	SDBB21320*2**	3000	3-Way
	SDBB21321*3**	SDBB21321*2**	4000	3-Way
	SDBB21222*3**	SDBB21222*2**	5000	2-Way
	SDBB21322*3**	SDBB21322*2**	5000	3-Way

Operating at Other Pressures May Affect Performance and Cycle Life

Replacement MultiSeal® Part Number.. SDBB2130108A or SDBB2130208A (5000 psi)  
 Recommended Installation Torque..... 25 ft\* lbs nominal  
 Installation Guide ..... PS P1186

\*Test Fluid: 0 = Skydrol, 1 = MIL-PRF-5606, MIL-PRF-83282

\*\* Electrical: A = Lead Wire Front, B = Lead Wire Rear, E = Connector

# Piloting Solenoid Valve

11

## DUAL COIL

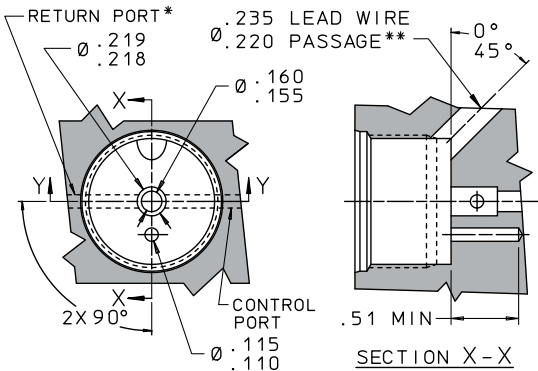
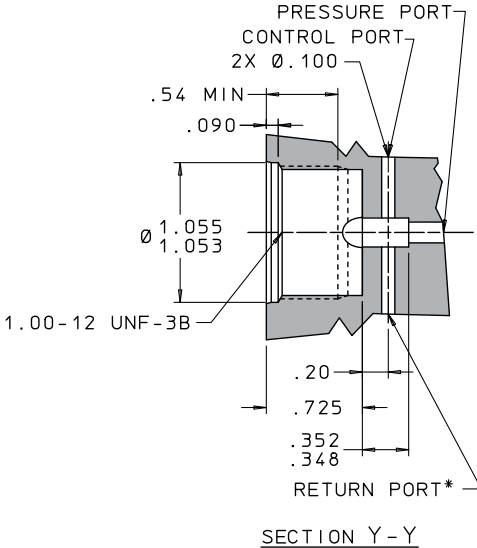

\* 3-Way version only

\*\* Lead wire front version only

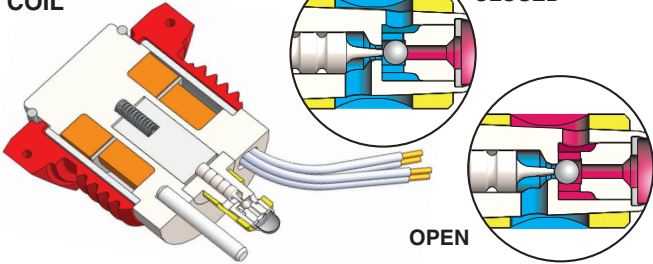
DUAL  
COIL**MATERIALS**

Body &amp; Ball Seat: 15-5 PH CRES/AMS 5659

MultiSeal®: Polyamide-Imide/AMS 3670

Ball &amp; Pin: 440C CRES/AMS 5630

Spring: 302 CRES/AMS 5688

Flanges, Plungers &amp; Cover: Si Iron BFM/ASTM A867

Filter Screen: 304L CRES/ASTM A666

Shunt: 22-13-5 CRES/AMS 5764

Shims &amp; Spacers: 302 CRES/ASTM A666

Shaft: 440C CRES/AMS-QQ-S-763

Plug &amp; Pushrod: 303 CRES/QQ-S-763C

Retainer: 2024 T-351 AL/AMS-QQ-A-225/6

Retaining Ring: 302 CRES/ASTM A313/A313M

Coil: Copper Magnet Wire/NEMA  
MW1000/MW16

Coil Separator (Dual Coil): ARAMID 410/MIL-I-24204

Lead Wire: 22 AWG/SAE AS22759/11-22

Shrink Tube: AMS-DTL-23053 / 8 &amp; / 12

Insulation Tape: Polyimide/ASTM D5213

Solder: Sb05A/J-STD-006

Brazo: AMS 4774

Potting Compound: Stycast 2762FT, Catalyst 17

Connector: Shell: 304L, Pins: Gold Plated,  
Seal: Fluorosilicone Elastomer

Connector Sleeve: 304 CRES/AMS-QQ-S-763

Connecting Wire: 26 AWG/SAE AS22759/11-26

**FINISH**

CRES Parts: Passivated

Soft Magnetic Material: Nickel Plate/AMS 2404

Retainer: Anodize/MIL-A-8625 Type II

## DUAL COIL

### OPERATING TEMPERATURE:

Ambient: -65°F to 275°F

Fluid: -65°F to 275°F

### LEAKAGE:

Internal: 1 cc/minute max. at rated pressure

External: 0 cc

### LOHM RATES:

3000 psi rated valve: 1800 Lohms

4000 psi rated valve: 2500 Lohms

5000 psi rated valve: 2800 Lohms

Operating at other pressures may affect performance and cycle life

### ELECTRICAL:

Current Drain: 0.35 amps at 28 Vdc at 70°F (9.8 Watts)  
(each coil)

Max. Operating Voltage: 32.2 Vdc

Pull In Voltage: 18 Vdc max. at 275°F and rated pressure to either coil

Drop Out Voltage: Both coils energized

1 Vdc min. at 70°F and rated pressure

Resistance: 74-86 Ohms at 70°F

Response Time:

Pull In: (28 Vdc at 70°F and rated pressure)

0.015 seconds max., normally closed version

0.040 seconds max., normally open version

Drop Out: (28 Vdc at 70°F and rated pressure)

0.015 seconds max., normally open version

0.035 seconds max., normally closed version

Stabilization Temperature: 285°F max. with 28 Vdc applied to both coils, suspended in 70°F to 110°F still air, continuously energized

Insulation Resistance: 100 Megohms min. with 500 Vdc applied for 60 seconds

Dielectric Strength: 1500 Vrms min. at 60 Hz for 60 seconds

### SCREEN HOLE SIZE:

.004 inches nominal

### WEIGHT:

.20 lbs. max.

## SINGLE COIL

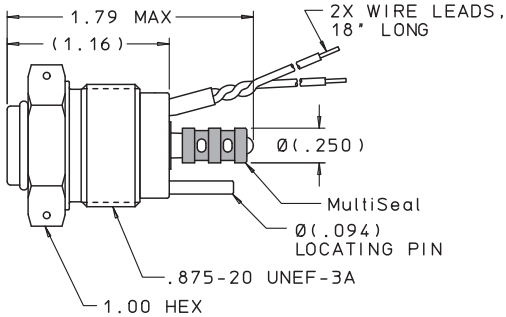

## DUAL COIL

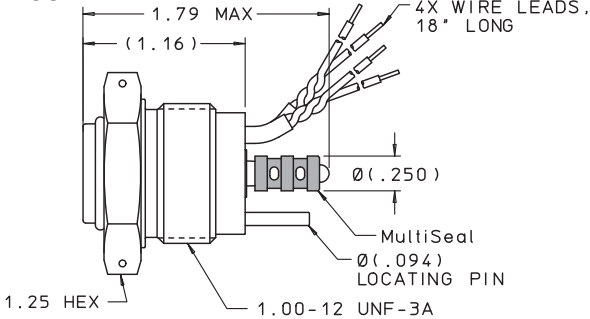

J

LEE PART NUMBER		COIL	TEST FLUID
NORMALLY CLOSED	NORMALLY OPEN		
SDBB2531003A	SDBB2531002A	Single	Skydrol
SDBB2531013A	SDBB2531012A	Single	MIL-PRF-5606, MIL-PRF-83282
SDBB2532003A	SDBB2532002A	Dual	Skydrol
SDBB2532013A	SDBB2532012A	Dual	MIL-PRF-5606, MIL-PRF-83282

Replacement MultiSeal® Part Number..... SDBB2530108A  
 Recommended Installation Torque..... 35 ft\* lbs nominal  
 Installation Guide ..... PS P1186

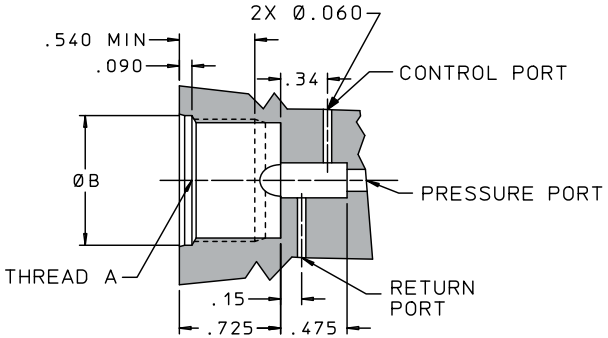

SECTION Y-Y

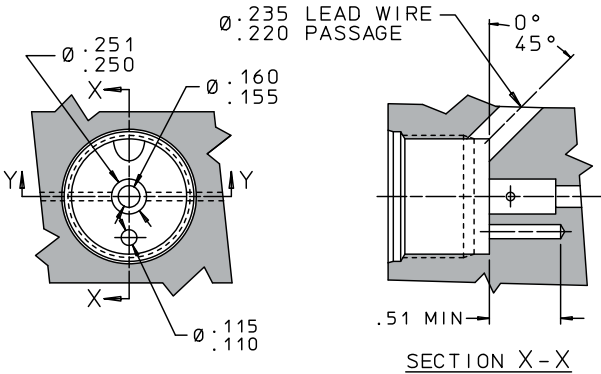

SECTION X-X

COIL TYPE	THREAD A	Ø B
Single Coil	.875 - 20 UNEF-3B	.928 - .930
Dual Coil	1.00 - 12 UNF-3B	1.053 - 1.055

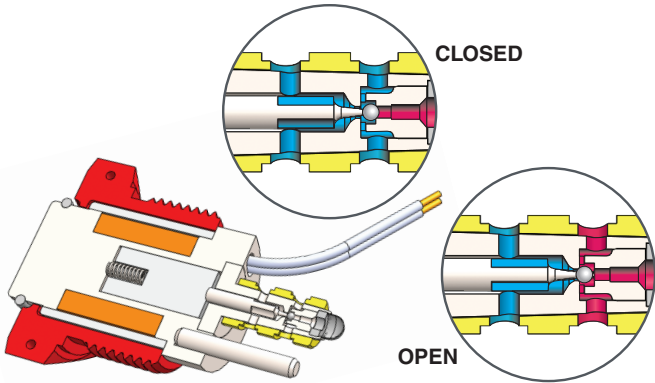
**MATERIALS**

Body &amp; Ball Seat: 15-5 PH CRES/AMS 5659

MultiSeal®: Polyamide-Imide/AMS 3670

Pushrod: 303 CRES/QQ-S-763C

Ball &amp; Pin: 440C CRES/AMS 5630

Spring: 302 CRES/AMS 5688

Shunt: 22-13-5 CRES/AMS 5764

Flanges, Plungers &amp; Cover: Si Iron BFM/ASTM A867

Filter Screen: 304L CRES/ASTM A666

Shims &amp; Spacer: 302 CRES/ASTM A666

Shaft: 440C CRES/AMS-QQ-S-763

Retainer: 2024 T-351 AL/AMS-QQ-A-225/6

Retaining Ring: 302 CRES/ASTM A313/A313M

Coil: Copper Magnet Wire/NEMA  
MW1000/MW16

Lead Wire: 22 AWG/SAE AS22759/11

Shrink Tube: AMS-DTL-23053 / 8 &amp; / 12

Insulation Tape: Polyimide/ASTM D5213

Solder: Sb05A/J-STD-006

Brazing: AMS 4774

Potting Compound: Stycast 2762FT, Catalyst 17

**FINISH**

CRES Parts: Passivated

Soft Magnetic Material: Nickel Plate/AMS 2404

Retainer: Anodize/MIL-A-8625 Type II

**PRESSURE:**

Operating: 3000 psi

Proof: 4500 psi

Burst: 7500 psi

**OPERATING TEMPERATURE:**

Ambient: -65°F to 275°F

Fluid: -65°F to 275°F

**LEAKAGE:** Internal: 1 cc/minute max. at rated pressure  
External: 0 cc

**LOHM RATE:** 3000 psi rated valve: 3500 Lohms  
Operating at other pressures may affect performance  
and cycle life

**ELECTRICAL:** (Single Coil)

Current Drain: 0.28 amps at 28 Vdc at 70°F (7.8 Watts)

Max. Operating Voltage: 32 Vdc

Pull In Voltage: 18 Vdc max. at 275°F and 3000 psi

Drop Out Voltage: 2 Vdc min. at 70°F and 3000 psi

Resistance: 92-108 Ohms at 70°F

Response Time:

Pull In: (28 Vdc at 70°F and 3000 psi)

0.035 seconds max.

Drop Out: (28 Vdc at 70°F and 3000 psi)

0.035 seconds max.

Insulation Resistance: 100 Megohms min. with 500  
Vdc applied for 60 seconds

Dielectric Strength: 1500 Vrms min. at 60 Hz  
for 60 seconds

**SCREEN HOLE SIZE:**

.004 inches nominal

**WEIGHT:**

Single Coil: .14 lbs. max.

Dual Coil: .21 lbs. max.

## 2-WAY SINGLE COIL

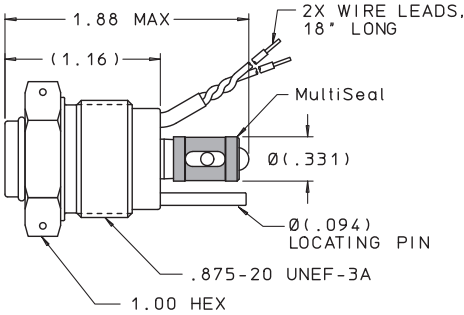

## 2-WAY DUAL COIL

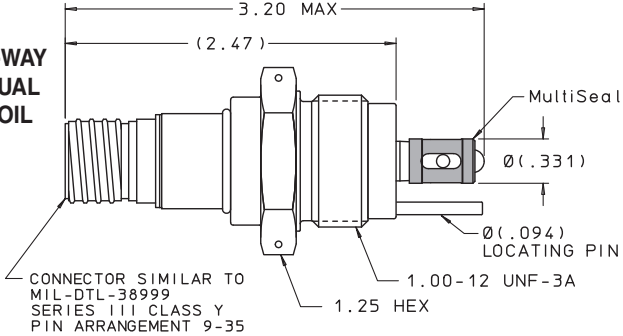

J

LEE PART NUMBER		COIL	TEST FLUID
NORMALLY CLOSED	NORMALLY OPEN		
SDHB3321003**	SDHB3321002**	Single	Skydrol
SDHB3321013**	SDHB3321012**	Single	MIL-PRF-5606, MIL-PRF-83282
SDHB3322003**	SDHB3322002**	Dual	Skydrol
SDHB3322013**	SDHB3322012**	Dual	MIL-PRF-5606, MIL-PRF-83282

Replacement MultiSeal® Part Number..... SDBB3320108A

Recommended Installation Torque..... 25 ft\*lbs nominal

Installation Guide ..... PS P1186

\*\* Electrical: A = Lead Wire Front, B = Lead Wire Rear, E = Connector

# 2-Way High Flow Solenoid Valve

19

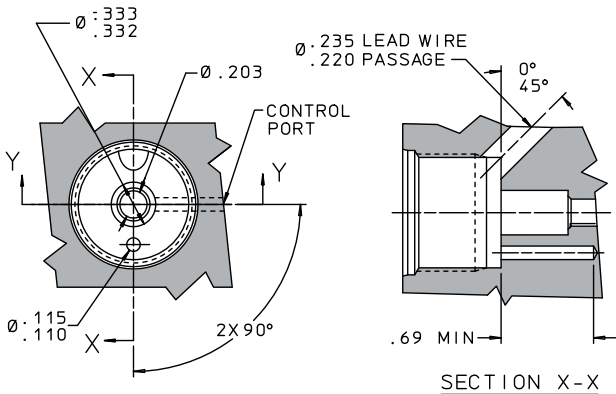
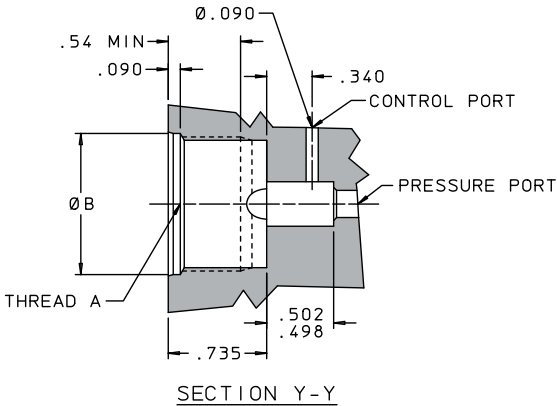

COIL TYPE	THREAD A	Ø B
Single Coil	.875 - 20 UNEF-3B	.928 - .930
Dual Coil	1.00 - 12 UNF-3B	1.053 - 1.055

J

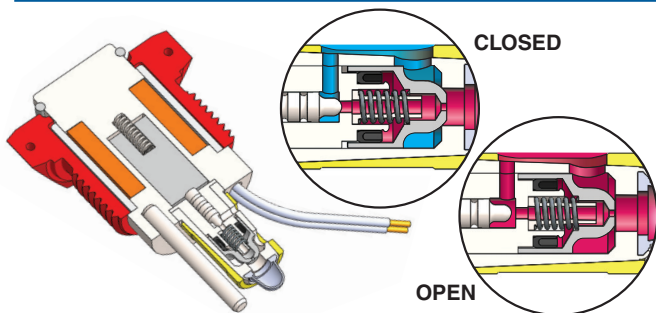
**MATERIALS**

Valve Body, Housing & Shaft:	15-5 PH CRES/AMS 5659
MultiSeal®:	Polyamide-Imide/AMS 3670
Ball & Pin:	440C CRES/AMS 5630
Springs:	302 CRES/AMS 5688
Spring Guide:	304 CRES/AMS-QQ-S-763
Flanges, Plungers & Cover:	Si Iron BFM/ASTM A867
Filter Screen:	304L CRES/ASTM A 666
Shunt:	22-13-5 CRES/AMS 5764
Seal:	Graphite Filled PTFE
Shaft, Poppet:	440C CRES/AMS-QQ-S-763
Retainer:	2024 T-351 AL/AMS-QQ-A-225/6
Retaining Ring:	302 CRES/ASTM A313/A313M
Coil:	Copper Magnet Wire/NEMA MW1000/MW16
Coil Separator (Dual Coil):	ARAMID 410/MIL-I-24204
Lead Wire:	22 AWG/SAE AS22759/11-22
Shrink Tube:	AMS-DTL-23053
Insulation Tape:	Polyimide/ASTM D5213
Solder:	Sb05A/J-STD-006
Braze:	AMS 4774
Potting Compound:	Stycast 2762FT, Catalyst 17
Connector:	Shell: 304L, Pins: Gold Plated, Seal: Fluorosilicone Elastomer
Connector Sleeve:	304 CRES/AMS-QQ-S-763
Connecting Wire:	26 AWG/SAE AS22759/11-26

**FINISH**

CRES Parts:	Passivated
Soft Magnetic Material:	Nickel Plate/AMS 2404
Retainer:	Anodize/MIL-A-8625 Type II

**PRESSURE:** Operating: 3000 psid      Proof: 4500 psi  
Minimum: 200 psid      Burst: 7500 psi

**OPERATING TEMPERATURE:**

Ambient: -65°F to 275°F

Fluid: -65°F to 275°F

**LEAKAGE:** Internal: 2 cc/minute max. at 3000 psi  
External: 0 cc

**LOHM RATE:** 200 Lohms maximum

**ELECTRICAL:**

Current Drain:

Single Coil - 0.28 amps at 28 Vdc at 70°F (7.8 Watts)

Dual Coil - 0.35 amps at 28 Vdc at 70°F (9.8 Watts)

Max. Operating Voltage: 32.2 Vdc

Pull In Voltage: 18 Vdc max. at 275°F and 3000 psi

Drop Out Voltage: 3.0 Vdc min. at 70°F and 3000 psi

Resistance: Single Coil: 92-108 Ohms at 70°F

Dual Coil: 74-86 Ohms at 70°F

Response Time:

Pull In: (28 Vdc at 70°F and 3000 psi) 0.03 seconds max.

Drop Out: (28 Vdc at 70°F and 3000 psi)

0.03 seconds max., normally closed version

0.05 seconds max., normally open version

Stabilization Temperature:

Single Coil: 235°F max. with 28 Vdc applied, suspended in 70°F to 110°F still air, continuously energized

Dual Coil: 285°F max. with 28 Vdc applied to both coils, suspended in 70°F to 110°F still air, continuously energized

Insulation Resistance: 100 Megohms min. with 500 Vdc applied for 60 seconds

Dielectric Strength: 1500 Vrms min. at 60 Hz for 60 seconds

**SCREEN HOLE SIZE:**

.004 inches nominal

**WEIGHT:**

Single Coil - .15 lbs. max.

Conn, SC - .18 max.

Dual Coil - .23 lbs. max.

Conn, DC - .25 max.

# 3-Way High Flow Solenoid Valve

**SINGLE COIL**

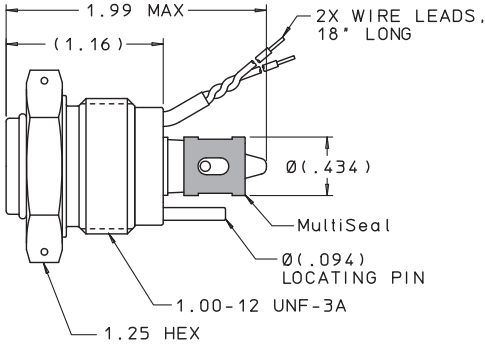

**SINGLE COIL**

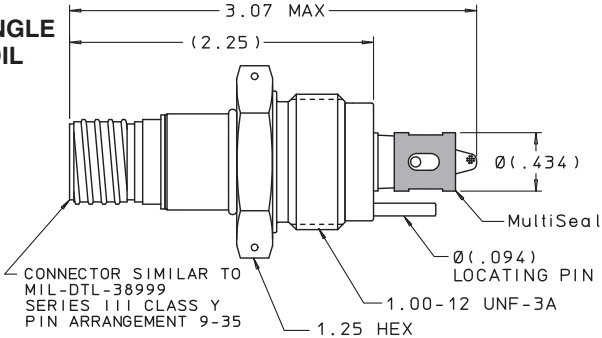

J

LEE PART NUMBER		COIL	TEST FLUID
NORMALLY CLOSED	NORMALLY OPEN		
SDHB4331003**	SDHB4331002**	Single	Skydrol
SDHB4331013**	SDHB4331012**	Single	MIL-PRF-5606, MIL-PRF-83282
SDHB4332003**	SDHB4332002**	Dual	Skydrol
SDHB4332013**	SDHB4332012**	Dual	MIL-PRF-5606, MIL-PRF-83282

Replacement MultiSeal® Part Number..... SDBB4330108A  
 Recommended Installation Torque..... 35 ft\* lbs nominal  
 Installation Guide ..... PS T1011

\*\* Electrical: A = Lead Wire Front, B = Lead Wire Rear, E = Connector

# 3-Way High Flow Solenoid Valve

23

## SINGLE COIL

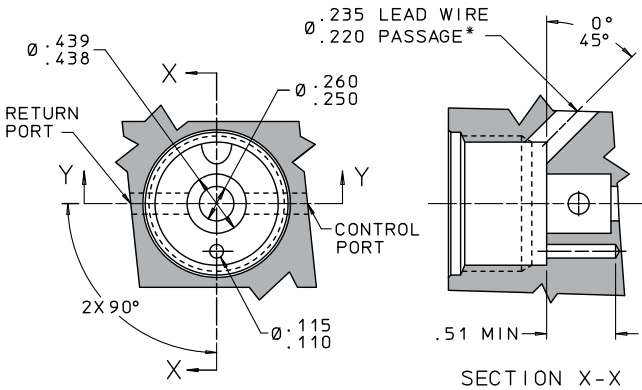
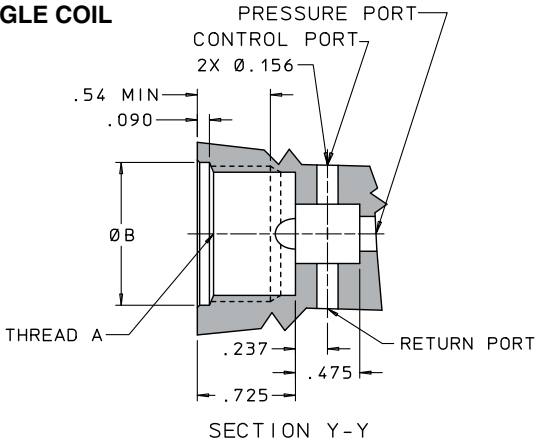

\* Lead wire front version

COIL TYPE	THREAD A	Ø B
Lead Wire Front	1.125 - 12 UNF	1.136 - 1.138
Lead Wire Rear	1.00 - 12 UNF	1.053 - 1.055
Connector	1.00 - 12 UNF	1.053 - 1.055

J

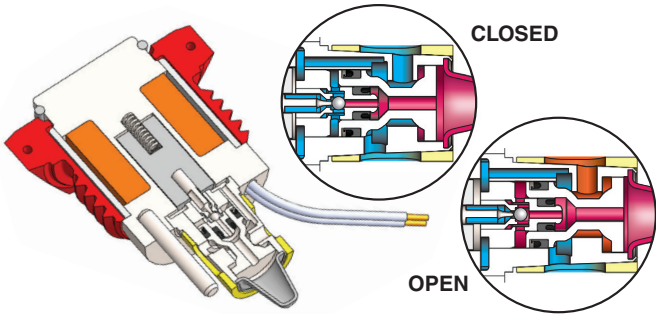
**MATERIALS**

Housing, Pilot, Shaft & Ball Seat:	15-5 PH CRES/AMS 5659
MultiSeal®:	Polyamide-Imide/AMS 3670
Ball & Pin:	440C CRES/AMS 5630
Springs:	302 CRES/AMS 5688
Flanges, Plungers & Cover:	Si Iron BFM/ASTM A867
Filter Screen:	17-4PH CRES/AMS 5604
Shunt:	22-13-5 CRES/AMS 5764
Seals:	Graphite Filled PTFE
Shaft & Poppets:	440C CRES/AMS-QQ-S-763
Retainer:	2024 T-351 AL/AMS-QQ-A-225/6
Retaining Ring:	302 CRES/ASTM A313/A313M
Coil:	Copper Magnet Wire/NEMA MW1000/MW16
Coil Separator (Dual Coil):	ARAMID 410/MIL-I-24204
Lead Wire:	22 AWG/SAE AS22759/11-22
Shrink Tube:	AMS-DTL-23053
Insulation Tape:	Polyimide/ASTM D5213
Solder:	Sb05A/J-STD-006
Braze:	AMS 4774
Potting Compound:	Stycast 2762FT, Catalyst 17
Seal Keeper:	416 CRES/QQ-S-763
Connector:	Shell: 304L, Pins: Gold Plated, Seal: Fluorosilicone Elastomer
Connector Sleeve:	304 CRES/AMS-QQ-S-763
Connecting Wire:	26 AWG/SAE AS22759/11-26

**FINISH**

CRES Parts:	Passivated
Soft Magnetic Material:	Nickel Plate/AMS 2404
Retainer:	Anodize/MIL-A-8625 Type II

**PRESSURE:** Operating: 3000 psid      Proof: 4500 psi  
Minimum: 250 psid      Burst: 7500 psi

**OPERATING TEMPERATURE:**

Ambient: -65°F to 275°F

Fluid: -65°F to 275°F

**LEAKAGE:** Internal: 2 cc/minute max. at rated pressure  
External: 0 cc

**LOHM RATE:** 300 Lohms

**ELECTRICAL:**

Current Drain:

0.28 amps at 28 Vdc at 70°F (7.8 Watts)

Max. Operating Voltage: 32.2 Vdc

Pull In Voltage: 18 Vdc max. at 275°F and 3000 psi

Drop Out Voltage: 1.5 Vdc min. at 70°F and 3000 psi

Resistance: 92-108 Ohms at 70°F

Response Time:

Pull In: (28 Vdc at 70°F at 3000 psi)

0.03 seconds nominal, normally closed version

0.05 seconds nominal, normally open version

Drop Out: (28 Vdc at 70°F at 3000 psi)

0.03 seconds nominal, normally closed version

0.05 seconds nominal, normally open version

Stabilization Temperature:

225°F max. with 28 Vdc applied, suspended

in 70°F to 110°F still air, continuously energized

Insulation Resistance: 100 Megohms min. with 500  
Vdc applied for 60 seconds

Dielectric Strength: 1500 Vrms min. at 60 Hz for 60 seconds

**SCREEN HOLE SIZE:**

.004 inches nominal

**WEIGHT:**

.28 lbs. max.

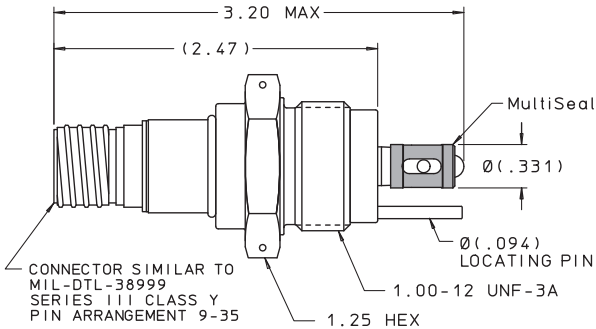
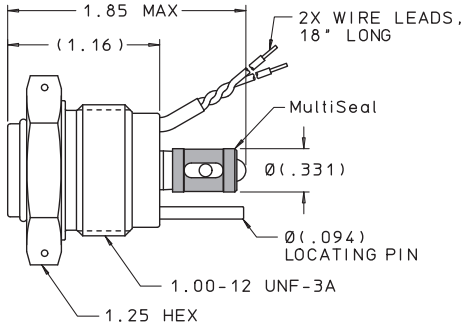

J

LEE PART NUMBER		COIL
NORMALLY CLOSED	NORMALLY OPEN	
SDPB3321013**	SDPB3321012**	Single
SDPB3322013**	SDPB3322012**	Dual

Replacement MultiSeal® Part Number..... SDBB3320108A  
 Recommended Installation Torque..... 25 ft\* lbs nominal  
 Installation Guide ..... PS P1186

\*\* Electrical: A = Lead Wire Front, B = Lead Wire Rear, E = Connector  
 Test Fluid: MIL-PRF-5606, MIL-PRF-83282 and Nitrogen

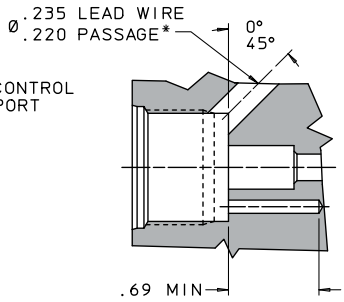
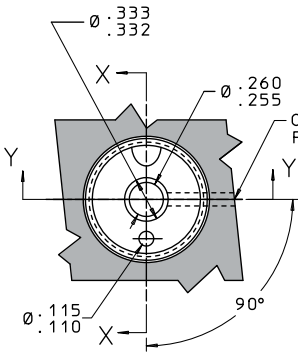
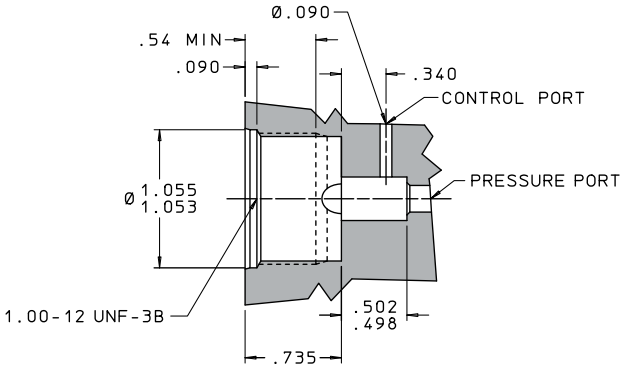

\* Lead wire front version

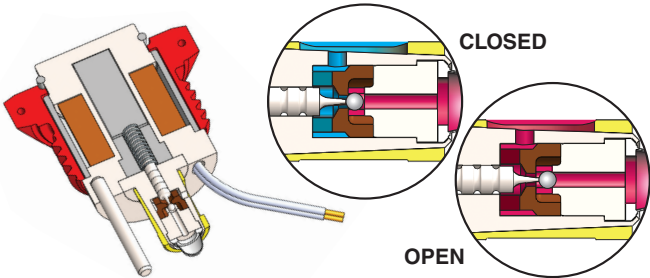

**MATERIALS**

Body &amp; Ball Guide: 15-5 PH CRES/AMS 5659

MultiSeal®: Polyamide-Imide/AMS 3670

Ball &amp; Pin: 440C CRES/AMS 5630

Ball Seat: Polyimide

Retainer: 2024 T-351 AL/AMS-QQ-A-225/6

Flanges, Plungers, Spring  
Guide & Cover: Si Iron BFM/ASTM A867

Spacers: 302 CRES/ASTM A666

Coil: Copper Magnet Wire/NEMA  
MW1000/MW16

Spring: 302 CRES/AMS 5688

Filter Screen: 304L CRES/ASTM A666

Shunt: 22-13-5 CRES/AMS 5764

Brazo: AMS 4774

Shaft: 440C CRES/AMS-QQ-S-763

Plug &amp; Pushrod: 303 CRES/AA-S-763C

Lead Wire: 22 AWG/SAE AS22759/11

Retaining Ring: 302 CRES/ASTM A313/A313M

Potting Compound: Stycast 2762FT, Catalyst 17

Solder: Sb05A/J-STD-006

Shrink Tube: AMS-DTL-23053

Insulation Tape: Polyimide/ASTM D5213

Connector: Shell: 304L, Pins: Gold Plated,  
Seal: Fluorosilicone Elastomer

Connector Sleeve: 304 CRES/AMS-QQ-S-763

Connecting Wire: 26 AWG/SAE AS22759/11

**FINISH**

CRES Parts: Passivated

Soft Magnetic Material: Nickel Plate/AMS 2404

Retainer: Anodize/MIL-A-8625 Type II

**PRESSURE:**

Operating: 500-3000 psid

Proof: 4500 psi

Burst: 7500 psi

**OPERATING TEMPERATURE:**

Ambient: -65°F to 275°F

Fluid: -65°F to 275°F

**LEAKAGE:** Internal: 0 Bubbles/minute on Nitrogen  
(500-3000 psi)  
External: 0 cc

**LOHM RATE:** 3000 psi rated valve: 3500 Lohms max.  
restriction

**ELECTRICAL:**

Current Drain: .280 amps at 28 Vdc at 70°F (7.8 watts)

Max. Operating Voltage: 32.2 Vdc

Pull In Voltage: 18 Vdc max. at 275°F and 3000 psi

Drop Out Voltage: 1.0 Vdc min. at 70°F and 3000 psi

Resistance: 92 - 108 Ohms at 70°F

Insulation Resistance: 100 Megohms min. with 500  
Vdc applied for 60 seconds

Dielectric Strength: 1500 Vrms min. at 60 Hz for 60  
seconds

**SCREEN HOLE SIZE:**

.004 inches nominal

**WEIGHT:**

.28 lbs. max.

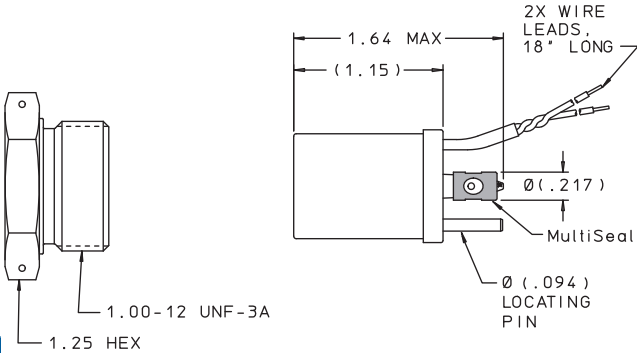
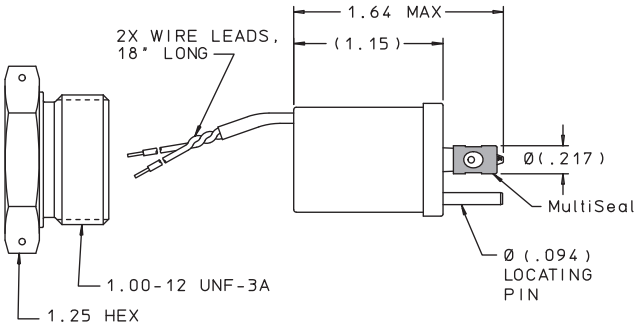

J

LEE PART NUMBER	PORTING	WIRE EXIT
SDLA2121033A	2-Way	Front
SDLA2121033B		Rear
SDLA2131033A	3-Way	Front
SDLA2131033B		Rear

### REPLACEMENT PART NUMBERS

MultiSeal® .....	SDBB2130108A
Retainer .....	SDBB2130009A

Test Fluid .....	HATCOL 2925
Recommended Installation Torque .....	25 ft* lbs nominal
Installation Guide .....	PS P1186

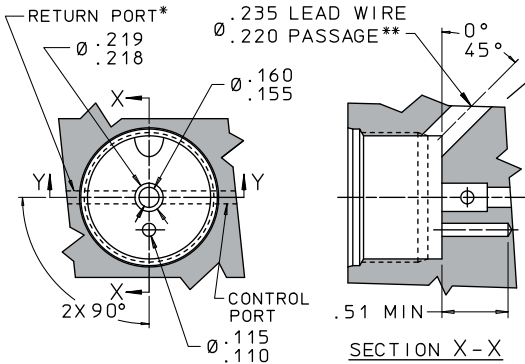
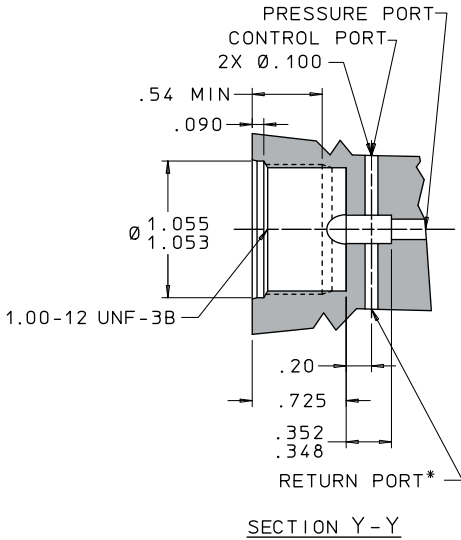

\* 3-Way version only

\*\* Lead wire front version only

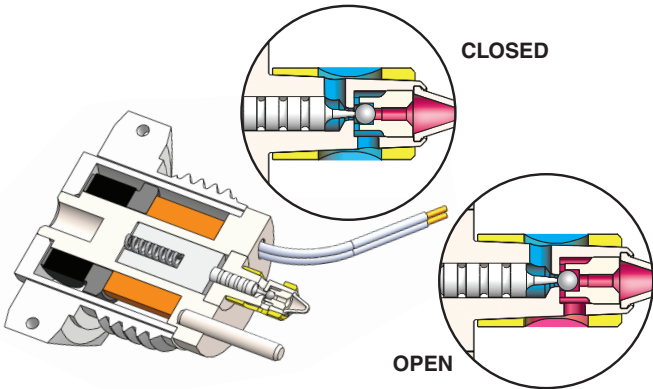
**MATERIALS**

Body, Filter Screen & Ball Seat:	15-5 PH CRES/AMS 5659
MultiSeal®:	Polyamide-Imide/AMS 3670
Ball & Pin:	440C CRES/AMS 5630
Spring:	Elgiloy/AMS 5833 or 17-7 PH CRES/AMS 5678
Flanges, Plungers & Cover:	Chrome Core 18-FM
Shrink Tube:	AMS-DTL-23053
Coil:	Copper Magnet Wire/NEMA MW1000/M16
Lead Wire:	22 AWG/SAE AS22759/11
Insulation Tape:	Polyimide/ASTM D5213
Solder:	Sb05A/J-STD-006
Braze:	AMS 4774
Potting Compound:	Stycast 2762FT, Catalyst 17
Magnet:	SmCo
Magnet Holder:	PEEK
Shunt:	22-13-5 CRES/AMS 5764
Spacer:	302 CRES/ASTM A666
Shaft:	440C CRES/AMS-QQ-S-763
Retainer:	2024 T-351 A/AMS-QQ-A-225/6
Pushrod:	304 CRES/AMS-QQ-S-763

**FINISH**

CRES Parts except Ball:	Passivated
Soft Magnetic Material:	Nickel Plate/AMS 2404
Retainer:	Clear Anodize/MIL-A-8625 Type II

## **PRESSURE:**

Operating: 3000 psi

Proof: 4500 psi

Burst: 7500 psi

## **OPERATING TEMPERATURE:**

Ambient: -65°F to 275°F

Fluid: -65°F to 275°F

**LEAKAGE:** Internal: 1 cc/minute max. at rated pressure  
External: 0 cc

**LOHM RATE:** 3000 psi rated valve: 2000 Lohms  
Operating at other pressures may affect performance  
and cycle life

## **ELECTRICAL:**

Current Drain: 1.2 amps at 12 Vdc at 70°F (14.5 Watts)

Operating Voltage Range: 12-14 Vdc (.083 - .097 amps) at  
275°F (10 - 13.5 Watts) and Pressure Port Pressurized  
to 3000 psid.

Extended periods of energization can lead to coil over-heat  
(recommended on time: 0.5 - 2.0 seconds).

Resistance: 8-12 Ohms at 70°F

Insulation Resistance: 100 Megohms min. with 500  
Vdc applied for 60 seconds

Dielectric Strength: 1500 Vrms min. at 60 Hz for 60  
seconds

## **SCREEN HOLE SIZE:**

.004 inches nominal

## **WEIGHT:**

0.2 lbs. max.

## SINGLE COIL

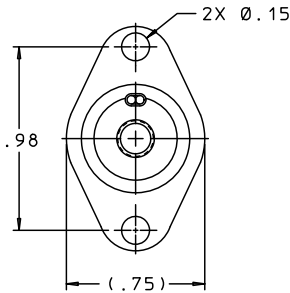
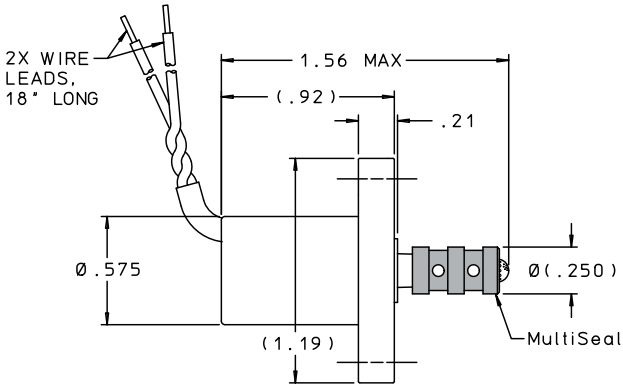

J

PART NUMBER	TYPE
SDBA2531012B	Normally Open
SDBA2531013B	Normally Closed

## SINGLE COIL

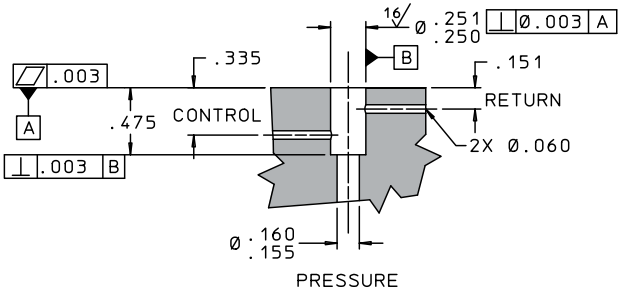
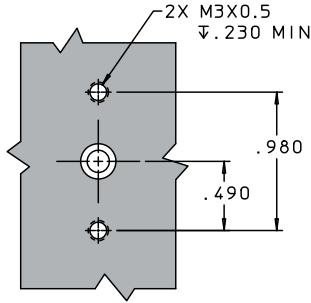

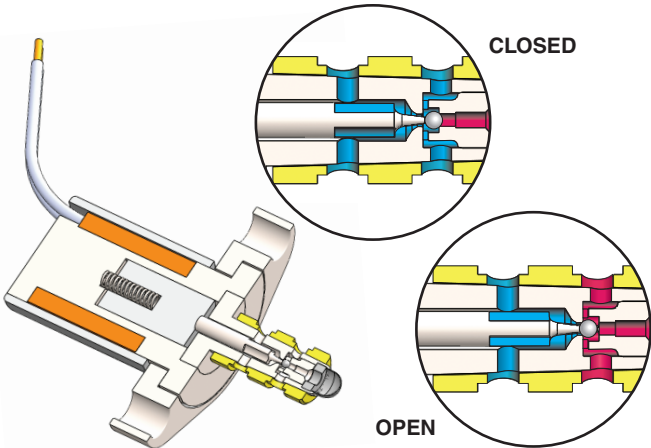
**MATERIALS**

Surface Mounting Plate,  
Body & Ball Seat: 15-5 PH CRES/AMS 5659

MultiSeal®: Polyamide-Imide/AMS 3670

Pushrod: 303 CRES/QQ-S-763C

Ball: 440C CRES/AMS 5630

Spring: 302 CRES/AMS 5688

Shunt: 304L CRES/AMS-QQ-S-763 or  
CRES/AMS 5764

Flanges, Plungers & Cover: Si Iron BFM/ASTM A867

Filter Screen: 304 CRES/ASTM A666

Spacer: 302 CRES/ASTM A666

Shaft: 440C CRES/AMS-QQ-S-763

Coil: Copper Magnet Wire/NEMA MW1000

Lead Wire: 24 AWG/SAE AS22759/11

Shrink Tube: AMS-DTL-23053/11, /12 & 13

Insulation Tape: Polyimide/ASTM D5213

Solder: Pb97B/J-STD-006

Braze: AMS 4774

Potting Compound: Stycast 2762 FT, Catalyst 17

**FINISH**

CRES Parts: Passivated

Soft Magnetic Material: Nickel Plate/AMS 2404

**PRESSURE:**

Operating: 3000 psi  
Proof: 4500 psi  
Burst: 7500 psi

**OPERATING TEMPERATURE:**

Ambient: 0°F to 265°F  
Fluid: 0°F to 265°F

**LEAKAGE:** Internal: 1 cc/minute max. at rated pressure  
External: 0 cc

**LOHM RATE:** 3000 psi rated valve: 3500 Lohms  
Operating at other pressures may affect performance  
and cycle life

**ELECTRICAL:**

Current Drain:

0.40 amps at 12 Vdc at 70°F (4.8 Watts)

Max. Operating Voltage: 15 Vdc

Pull In Voltage: 12 Vdc max. at 265°F and  
rated pressure

Drop Out Voltage: 1.0 Vdc min. at 70°F and  
rated pressure

Resistance: 27- 33 Ohms at 70°F

Response Time:

Pull In: (12 Vdc at 70°F and 3000 psi)

0.015 seconds max., normally closed version

0.040 seconds max., normally open version

Drop Out: (12 Vdc at 70°F and 3000 psi)

0.035 seconds max., normally closed version

0.015 seconds max., normally open version

Insulation Resistance: 100 Megohms min. with 500  
Vdc applied for 60 seconds

Dielectric Strength: 1000 Vrms min. at 60 Hz for 60  
seconds

**SCREEN HOLE SIZE:**

.004 inches nominal

**WEIGHT:**

0.10 lbs. max.

The IEP Series is a miniature, two-way, high speed, normally closed solenoid valve capable of controlling small volumes of liquids or gasses. The IEP Series is typically used in CubeSat and small satellite propulsion systems as a thruster or control valve. The IEP Series is suitable for use in cold gas, pulsed plasma, and electronic propulsion systems and can be used in some mono-propellant and bi-propellant thrusters.

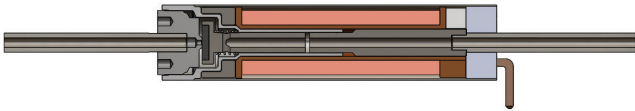
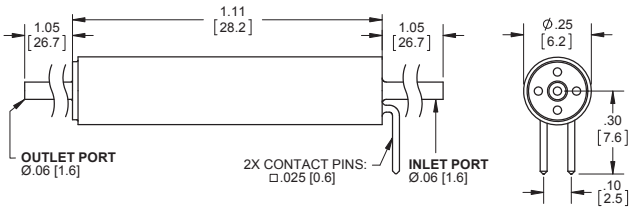

### PERFORMANCE:

- Response time: As fast as 0.5 ms, frequency up to 500 Hz
- Ambient Operating Temperature up to 275°F
- Operating Pressures up to 800 psig
- Weight: 0.17 oz.
- Internal Volume: 62  $\mu$ L
- Lohm Rate: 4100 Lohms
- Standard Porting: 1/16" Tubing, compatible with compression fittings

### MATERIALS:

- Wetted Materials: 316SS, FeCr Alloy, Seal Material (EPDM, FKM or FFKM available)

Unless otherwise specified, dimensions are in inches [mm]. Drawings are not to scale.

## CUSTOM CAPABILITIES

We offer a broad line of standard solenoid valves, but meeting the exact requirements of a particular application often requires a custom solution. Our solenoid valves can be customized to meet your needs, whether that requires operating in extreme environments, accommodating electrical requirements or modifying the hydraulic interface.



# Positive Displacement Pumps



K

- Qualified for 1000 Hours of Operation**
- Self-Priming**
- Reduces Likelihood of Cavitation**
- Superior Contamination Resistance**
- High Volumetric Efficiency Across the Rated Pressure Range**
- Variable Speed for Optimal Efficiency Under Changing Conditions**
- Aerospace Proven Brushless DC Motor for Precise Control of Flow**
- 71°F to +230°F Temperature Range**
- 100% Tested and Inspected**
- Compatible with Most Fuels and Petroleum Based Fluids**

**TABLE OF CONTENTS**

<b>60 Series Pump</b>	(60 pph of Flow at 100 psig)..... 4 – 5
<b>200 Series Pump</b>	(200 pph of Flow at 100 psig)..... 6 – 7

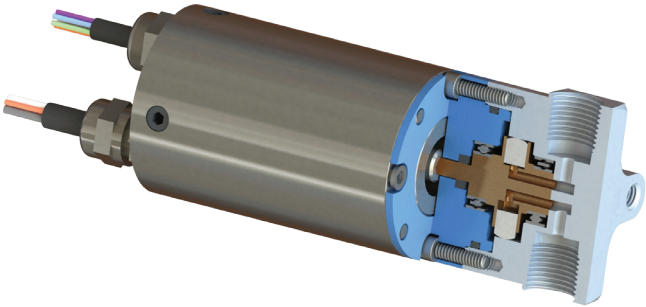

Lee Positive Displacement Pump's unique radial piston design aids in self-priming at altitude and reduces cavitation. Lee pumps are qualified for 1000 hours of operation and to numerous aerospace specifications. As an industry leader in durability and efficiency, they are ideal for fuel systems of small to medium sized Unmanned Aerial Systems and a variety of other demanding applications.

The self-priming capability is a result of the tight tolerances held between bore and pistons. It is not meant to pump air for long periods of time, as it needs liquid for lubrication, but it can pump air well enough to clear it from the pump and pull in fluid from the tank even at the low atmospheric pressures of altitude. These tight tolerances also lead to very high efficiency across the entire pressure range. This results in very predicable flows at high pressures.

Because the volume displaced by each of the pistons is relative large, the fluid velocity is relatively low for a given flow. This lower fluid velocity greatly reduces the likelihood of cavitation.

Lee Positive Displacement Pumps include an integrated brushless DC servo motor with hall sensor feedback to allow for precise control of variable flow. The materials used are compatible with most fuels and petroleum based fluids. These pumps continue the Lee tradition of delivering performance and quality in the smallest, lightest weight package available.

Custom designs with filter screens, integrated drive and control, and alternate materials are available.

# 4

# 60 Series Positive Displacement Pumps

Lee Part Number GPRA0601521C

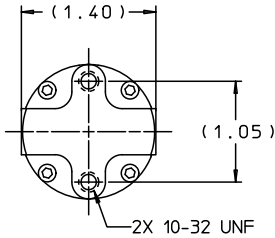
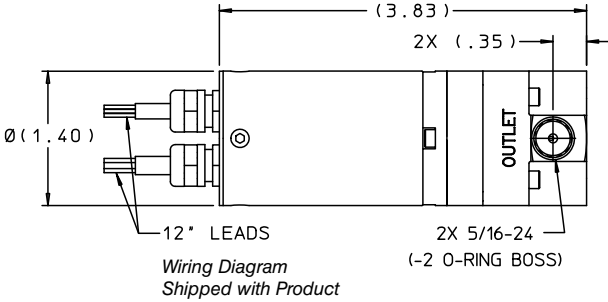

## WETTED MATERIALS

- 7075 Anodized Aluminum
- Fluorosilicone
- 15-5PH Cres
- 17-7PH Cres
- 400 Series Cres
- 300 Series Cres
- PTFE
- Nickel Aluminum Bronze

K

## PERFORMANCE DATA

Nominal Flow:..... 60 PPH  
 Discharge Pressure Range:..... 15 - 115 psia  
 Temperature Range:..... - 71°F to +230°F  
 Servo Motor:  
   Speed Range:.....1100-6500 RPM at 115 psia  
   Operating Voltage:.....12-28 Vdc  
   Nominal Power Required at 115 psia:.....24 W

## TYPICAL PERFORMANCE AT 70°F

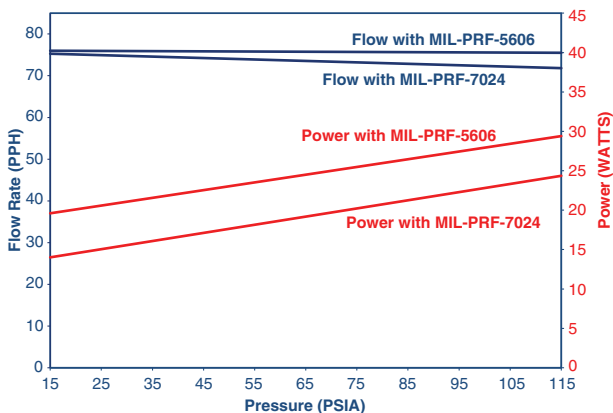

## TYPICAL PERFORMANCE MIL-PRF-7024 AT 70°F

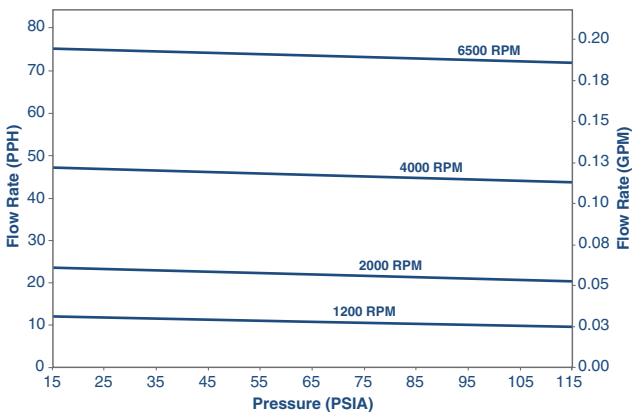

# 6

# 200 Series Positive Displacement Pumps

Lee Part Number GPRA2001521C

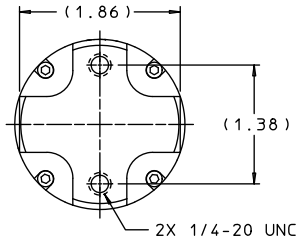
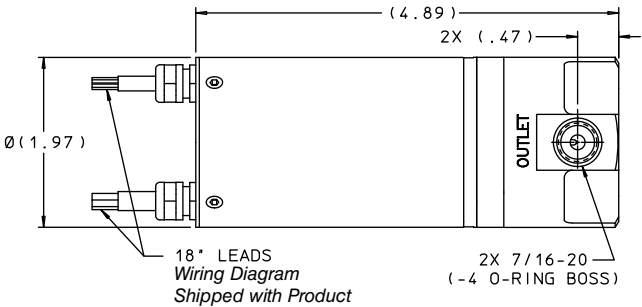

## WETTED MATERIALS

- 7075 Anodized Aluminum
- Fluorosilicone
- 15-5PH Cres
- 17-7PH Cres
- 400 Series Cres
- 300 Series Cres
- UHMWPE
- Phenolic
- Nickel Aluminum Bronze

K

## PERFORMANCE DATA

Nominal Flow:..... 200 PPH  
 Discharge Pressure Range:..... 15-115 psia  
 Temperature Range:..... -71°F to +230°F  
 Servo Motor:  
   Speed Range:.....1050-6500 RPM at 115 psia  
   Operating Voltage:..... 12-28 Vdc  
   Nominal Power Required at 115 psia:.....68 W

## TYPICAL PERFORMANCE AT 70°F

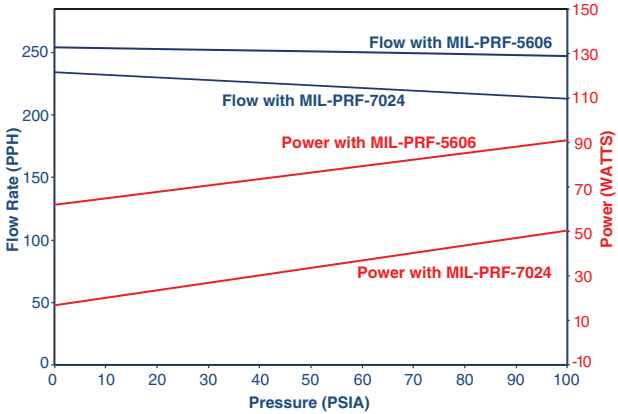

## TYPICAL PERFORMANCE MIL-PRF-7024 AT 70°F

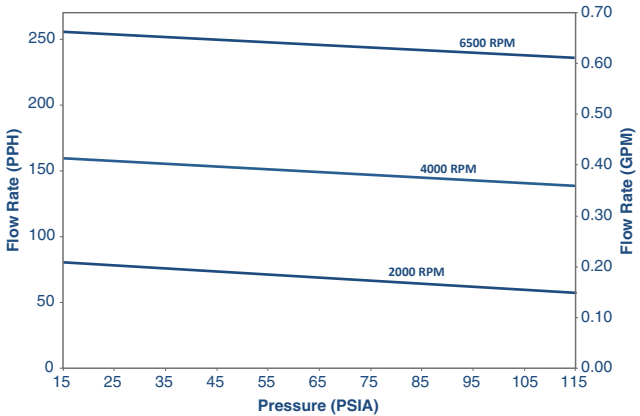

# Lee Line Mounts



## UNIONS

- ❑ Specially Designed to Accept Most Lee Inserts
- ❑ Available in Three Styles: Flared, Flareless and Dynamic Beam Seal
- ❑ Stainless Steel or Titanium Construction
- ❑ Distinctive Appearance and Permanent Marking

## LINE MOUNT

- ❑ Axial Visco Jets in Convenient Line Mount
- ❑ 43 and 68 Series Visco Jets in Line Mount
- ❑ Hi-Q Line Mount Chek Valve

## RING LOCKED ADAPTERS

- ❑ Integral Restrictors, Safety Screens and Valves in Ring Locked Adapters
- ❑ Constructed using Lightweight Titanium Adapters
- ❑ Unique Blue Lock Ring Makes Identification Easy

**TABLE OF CONTENTS****Lee Inserts In Unions**

Dash 4 Unions .....	6 – 8
Dash 6 Unions .....	9 – 11
Dash 4 to Dash 6 Unions .....	12

**Lee Line Mount Components**

Axial Visco Jets .....	13 – 14
43 and 68 Series Visco Jets.....	15 – 17
Hi-Q Chek Valve.....	18 – 19

**Lee Components in Ring Locked Adapters**

Lee Restrictors	
Dynamic Beam Seal Tube End.....	20 – 23
Flareless Tube End.....	24 – 27
Metric Dynamic Beam Seal Tube End .....	28 – 31
Lee Inlet Safety Screens .....	32 – 33
Lee Valves	
Inlet Cheks	
Dynamic Beam Seal Tube End .....	34 – 35
Flareless Tube End .....	36 – 37
Metric Dynamic Beam Seal Tube End ....	38 – 39
Return Cheks	
Dynamic Beam Seal Tube End .....	40 – 41
Flareless Tube End .....	42 – 43
Metric Dynamic Beam Seal Tube End ...	44 – 45
Flow Controls	
Dynamic Beam Seal Tube End .....	46 – 47
Flareless Tube End .....	48 – 49
Metric Dynamic Beam Seal Tube End ...	50 – 51

## LEE UNIONS

Virtually every .187, .250 and .281 inch diameter Lee insert is offered already installed in appropriately sized flared, flareless or dynamic beam seal unions. These unions are made of 304 stainless steel (code “J” in military standards) or 6AL-4V Titanium (code “T”). All Lee Unions have a unique hex wrench arrangement to distinguish them from simple unions and permanent external marking to identify the insert.

The configuration of these unions has been carefully chosen to accommodate most of the .187, .250 and .281 inch Lee inserts, and yet maintain both minimum envelope and weight. These units incorporate the high-root-radius UNJF threads to minimize stress concentrations with Class 3A tolerances. All fitting-end dimensions are, except for the internal diameters, in general accordance with the appropriate AS4375E4 and E6, AS4395E04 and E06, and AS85720/1-04 and -06 specifications.

Every Lee Union with insert installed is proof pressure tested; flared and flareless to 6000 psid and dynamic beam seal to 16,000 psid. Maximum working differential pressure is a function of the particular Lee insert specified (refer to the appropriate insert section).

## LINE MOUNT RESTRICTORS

All of the standard cartridge 43 and 68 Series Visco Jets, and all of the standard Axial Visco Jets, are also available built into unions with AS4395E04 flared ends. Different style or size ends are available on a special order basis.

### **LEE COMPONENTS IN RING LOCKED ADAPTERS**

Virtually all Lee miniature components, including check valves, flow controls, restrictors and screens, are available already installed or built into Ring Locked Adapters. Design engineers can now take advantage of the unused space in their Ring Locked Adapters to save space and weight in their manifolds.

The Lee Company offers all these products in Ring Locked Adapters with three different tube ends: dynamic beam seal, flareless and metric dynamic beam seal (8° 30' lip-seal). Dynamic beam seal and flareless tube versions range in size from -4 to -10 (1/4 to 5/8 inch) and metric lip-seal versions range from 6 to 16mm nominal tube O.D. Titanium has been selected as the adapter material for the lowest possible weight (see chart on opposite page). All Ring Locked Adapters containing Lee components have blue lock rings to distinguish them from ordinary Adapters, and permanent external marking to identify the function of the product inside.

### **LEE RESTRICTORS**

Lee miniature restrictors are available in both one-way (flow controls) and two-way configurations. Lee Flow Controls are built directly into Ring Locked Adapters for low pressure drop in the free flow direction. The two-way restrictors are Lee 5k Jets, Lee High Pressure High Watt Jets, Bender Jets, and Visco Jets installed as inserts in Ring Locked Adapters.

### **INLET SCREENS**

Lee Inlet Safety Screens feature all stainless steel construction. They are rated for use in 5000 psi systems and will withstand a proof pressure of 7500 psi in either direction without burst or collapse when fully clogged.

Lee Inlet Safety Screens have a large open area for maximum dirt carrying capacity and good low temperature performance. Additionally, the large open area guarantees the lowest possible pressure drop under all flow conditions.

### LEE CHEK VALVES

Miniature Lee Chek valves are built directly into Ring Locked Adapters for the lowest possible pressure drop, and are available in both inlet and return line configurations. The inlet Cheks are available with an inlet safety screen that can be easily removed for cleaning or inspection. Simply reinstall the cleaned screen with a new pin, without removing the adapter.

### NOMINAL WEIGHTS OF LEE PRODUCTS IN RING LOCKED ADAPTERS (grams)

TUBE SIZE	INLET CHEK	RETURN CHEK	FLOW CONTROL	RESTRICTOR	INLET SCREEN
<b>DYNAMIC BEAM SEAL TUBE</b>					
04	16.1	—	—	12.0	13.0
06	28.9	23.8	21.1	—	22.0
08	49.5	44.5	40.6	—	41.5
10	76.0	71.3	60.1	—	63.5
<b>FLARELESS TUBE</b>					
04	17.0	—	—	12.0	14.5
06	31.5	26.3	22.5	—	23.5
08	54.5	47.5	43.1	—	45.7
10	81.5	75.3	62.3	—	70.0
<b>METRIC DYNAMIC BEAM SEAL TUBE</b>					
06	23.6	—	—	14.0	15.0
08	25.6	24.4	—	—	21.5
10	34.6	—	24.6	—	30.0
12	—	45.0	—	—	40.0
14	69.2	—	59.2	—	58.5
16	—	71.0	—	—	73.0

## 6

## Dash 4 Stainless Steel Lee Unions

**STYLE "B"  
FLARED**

Ends similar  
to AS4395E04

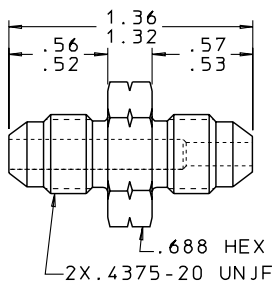
**STYLE "C"  
FLARELESS**

Ends similar  
to AS4375E04

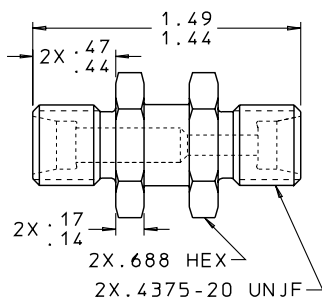

Material.....	304 Cres (AMS QQ-S-763)
Proof Pressure .....	6000 psi
Nominal Weight "B".....	23.3 grams
Nominal Weight "C".....	28.9 grams

**STANDARD CONFIGURATIONS**

STANDARD INSERT PRODUCT LINE	STANDARD INSERT PART # PREFIX	CONVERTED PREFIX	
		FLARED	FLARELESS
Lee Jet	JETA	JETB	JETC
High Watt Jet	JEHA	JEHB	JEHC
Bender Jet	JEBA	JEBB	JEBC
Jeva	JEVA	JEVB	JEVC
18 Series Visco Jet	VDCA	VDCB	VDCC
Restrictor Chek	RCRA	RCRB	RCRC
187 Flow Control	FCRA	FCRB	FCRC
187 Lee Chek	CKRA	CKRB	CKRC
187 Lo-Lohm Chek	CKRA	CKRB	CKRC
187 Zero Leak Chek	CSRA	CSRB	CSRC
187 Lee PRI	PRFA	PRFB	PRFC
Lee TRI	PRTA	PRTB	PRTC

Example: Insert Part Number JETA1872800L becomes JETB1872800L in a "B" Union.

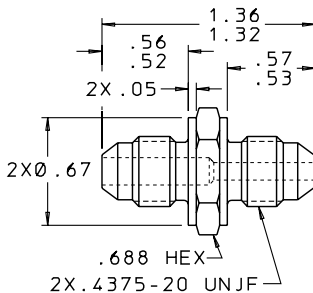

## STYLE "E" FLARED

Ends similar  
to AS4395E04

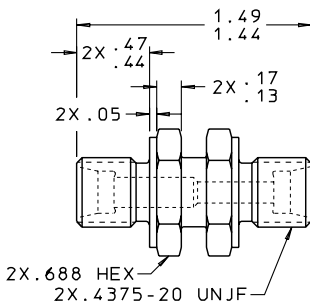

## STYLE "F" FLARELESS

Ends similar  
to AS4375E04

Material.....	6AL-4V Ti (AMS 4965)
Proof Pressure .....	6000 psi
Nominal Weight "E".....	12.3 grams
Nominal Weight "F".....	15.3 grams

## STANDARD CONFIGURATIONS

STANDARD INSERT PRODUCT LINE	STANDARD INSERT PART # PREFIX	CONVERTED PREFIX	
		FLARED	FLARELESS
Lee Jet	JETA	JETE	JETF
High Watt Jet	JEHA	JEHE	JEHF
Bender Jet	JEBA	JEBE	JEBF
Jeva	JEVA	JEVE	JEVF
18 Series Visco Jet	VDCA	VDCE	VDCF
Restrictor Chek	RCRA	RCRE	RCRF
187 Flow Control	FCRA	FCRE	FCRF
187 Lee Chek	CKRA	CKRE	CKRF
187 Lo-Lohm Chek	CKRA	CKRE	CKRF
187 Zero Leak Chek	CSRA	CSRE	CSRF
187 Lee PRI	PRFA	PRFE	PRFF
Lee TRI	PRTA	P RTE	PRTF

Example: Insert Part Number JETA1872800L becomes JETE1872800L in an "E" Union.

# 8

# Dash 4 Titanium Lee Unions

## STYLE "G" DYNAMIC BEAM SEAL

Ends similar  
to AS85720/1-04

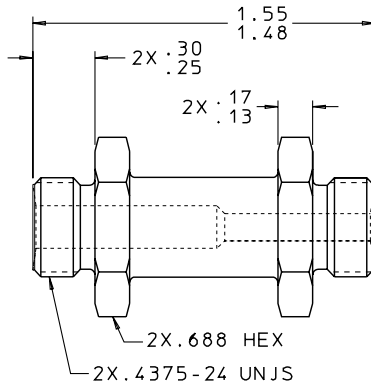

Material.....6AL-4V Ti (AMS 4965)  
 Proof Pressure .....16,000 psi  
 Nominal Weight .....19.9 grams

### STANDARD CONFIGURATIONS

STANDARD INSERT PRODUCT LINE	STANDARD INSERT PART # PREFIX	CONVERTED PREFIX
Lee Jet	JETA	JETG
High Watt Jet	JEHA	JEHG
Bender Jet	JEBA	JEBG
Jeva	JEVA	JEVG
18 Series Visco Jet	VDCA	VDCG
Restrictor Chek	RCRA	RCRG
187 Flow Control	FCRA	FCRG
187 Lee Chek	CKRA	CKRG
187 Lo-Lohm Chek	CKRA	CKRG
187 Zero Leak Chek	CSRA	CSRG
187 Lee PRI	PRFA	PRFG
Lee TRI	PRTA	PRTG
5K Jet	JHTA	JHTG
High Pressure High Watt	JHHA	JHHG
High Pressure Bender Jet	JHBA	JHBG
High Pressure Visco Jet	VHCA	VHCG
High Pressure 187 Chek	CHRA	CHRG

Example: Insert Part Number JETA1872800L becomes JETG1872800L in a "G" Union.

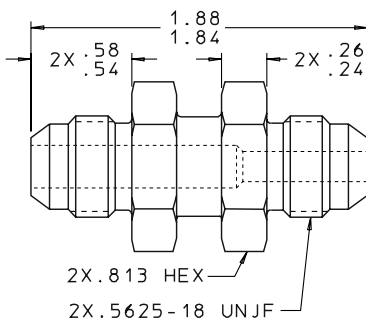

## STYLE "B" FLARED

*Ends similar  
to AS4395E06*

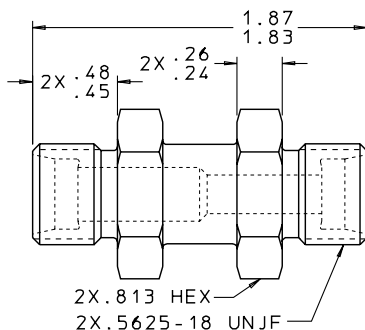

## STYLE "C" FLARELESS

*Ends similar  
to AS4375E06*

Material.....	304 Cres (AMS QQ-S-763)
Proof Pressure .....	6000 psi
Nominal Weight "B".....	57.7 grams
Nominal Weight "C".....	53.6 grams

## STANDARD CONFIGURATIONS

STANDARD INSERT PRODUCT LINE	STANDARD INSERT PART # PREFIX	CONVERTED PREFIX	
		FLARED	FLARELESS
281 Flow Control	FCRA	FCRB	FCRC
281 Flosert	FLFA	FLFB	FLFC
250 Lee Chek	CKRA	CKRB	CKRC
250 Lo-Lohm Chek	CKRA	CKRB	CKRC
250 Zero Leak Chek	CSRA	CSRB	CSRC
281 Kilowatt Jet	JEKA	JEKB	JEKC
281 PRI	PRFA	PRFB	PRFC

Example: Insert Part Number FCRA2815250L becomes FCRB2815250L in a "B" Union.

# 10 Dash 6 Titanium Lee Unions

## STYLE "E" FLARED

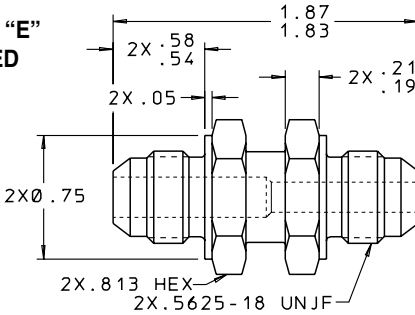

Ends similar  
to AS4395E06

## STYLE "F" FLARELESS

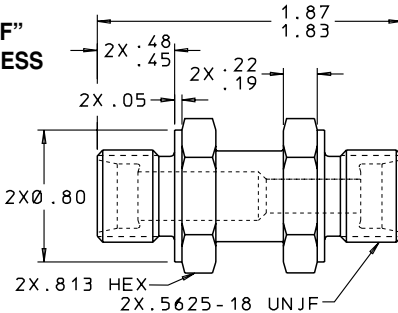

Ends similar  
to AS4375E06

Material.....	6AL-4V Ti (AMS 4965)
Proof Pressure .....	6000 psi
Nominal Weight "E" .....	31.0 grams
Nominal Weight "F" .....	29.9 grams

## STANDARD CONFIGURATIONS

STANDARD INSERT PRODUCT LINE	STANDARD INSERT PART # PREFIX	CONVERTED PREFIX	
		FLARED	FLARELESS
250 Lee Chek	CKRA	CKRE	CKRF
250 Lo-Lohm Chek	CKRA	CKRE	CKRF
250 Zero Leak Chek	CSRA	CSRE	CSRF
281 Flow Control	FCRA	FCRE	FCRF
281 Flosert	FLFA	FLFE	FLFF
281 Kilowatt Jet	JEKA	JEKE	JEKF
281 PRI	PRFA	PRFE	PRFF

Example: Insert Part Number FCRA2815250L becomes FCRE2815250L in an "E" Union.

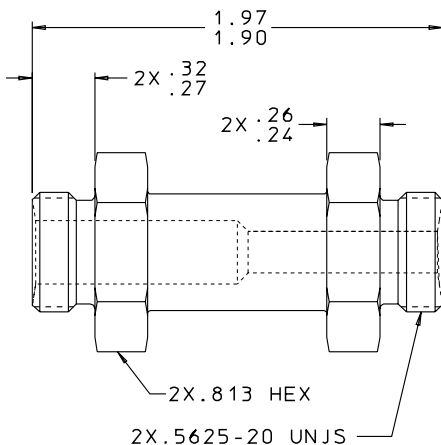

## STYLE "G" DYNAMIC BEAM SEAL

Ends  
similar to  
AS85720/1-06

Material.....	6AL-4V Ti (AMS 4965)
Proof Pressure .....	16,000 psi
Nominal Weight .....	30.7 grams

## STANDARD CONFIGURATIONS

STANDARD INSERT PRODUCT LINE	STANDARD INSERT PART # PREFIX	CONVERTED PREFIX
250 Lee Chek	CKRA	CKRG
250 Lo-Lohm Chek	CKRA	CKRG
250 High Pressure Chek	CHRA	CHRG
250 Zero Leak Chek	CSRA	CSRG
250 High Pressure TRI	PHTA	PHTG
281 Flow Control	FCRA	FCRG
281 Flosert	FLFA	FLFG
281 Kilowatt Jet	JEKA	JEKG
281 PRI	PRFA	PRFG
281 High Pressure PRI	PHFA	PHFG

Example: Insert Part Number FCRA2815250L becomes FCRG2815250L in a "G" Union.

# 12 Dash 6 to 4 Lee Unions

## STYLE "H" DYNAMIC BEAM SEAL

Ends similar to AS85720/1-04 & -06

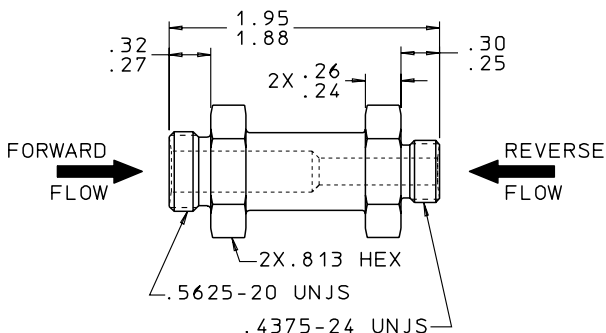

Material..... 6AL-4V Ti (AMS 4965)  
 Proof Pressure ..... 16,000 psi  
 Nominal Weight ..... 29.4 grams

### STANDARD CONFIGURATIONS

STANDARD INSERT PRODUCT LINE	STANDARD INSERT PART # PREFIX	CONVERTED PREFIX	
		FORWARD	REVERSE
250 Lee Chek	CKFA/CKRA	CKFH	CKRH
250 Lo-Lohm Chek	CKFA/CKRA	CKFH	CKRH
250 High Pressure Chek	CHFA/CHRA	CHFh	CHRh
250 Zero Leak Chek	CSFA/CSRA	CSFH	CSRh
250 High Pressure TRI	PHFA/PHRA	PHFH	PHRH
281 Flow Control	FCFA/FCRA	FCFH	FCRH
281 Flosert	FLFA/FLRA	FLFH	FLRH
281 PRI	PRFA/PRRA	PRFH	PRRH
281 High Pressure PRI	PHFA/PHRA	PHFH	PHRH
281 Kilowatt Jet	JEKA	JEKH*	

Example: Insert Part Number FCRA2815250L becomes FCRH2815250L in an "H" Union.  
 To change Flow Directions FCRH2815250L becomes FCFH2815250L.

\*Bidirectional Flow

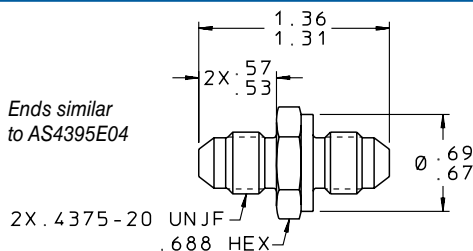

<b>MATERIALS</b>		
PART	MATERIAL	SPECIFICATION
Fitting	304 Cres	AMS QQ-S-763
Stack Retainer	303 Cres	QQ-S-763C
Spacers	303 Cres	QQ-S-763C
Shims	303 Cres	QQ-S-763C
Spinner Discs	17-7PH Cres	AMS 5528
Metering Discs	17-7PH Cres	AMS 5529
Pin	17-4PH Cres	AMS 5643
Screens	303 Cres	QQ-S-763C
	304L Cres	ASTM A 666
Braze	—	AMS 4774

*Finish: All Cres Parts Passivated.*

<b>PERFORMANCE</b>	
Lohm Rate Tolerance.....	±5%
Maximum Working Pressure.....	3000 psid
Proof Pressure.....	6000 psi
Nominal Weight.....	30.0 grams

LEE PART NUMBER	LOHM RATE	NOM. PASSAGE SIZE (Inches)	NOM. SCREEN HOLE SIZE (Inches)
VXLA2500680L	680	0.060	0.031
VXLA2500910L	910	0.060	0.031
VXLA2500120D	1200	0.050	0.031
VXLA2500140D	1400	0.050	0.031
VXLA2500190D	1900	0.045	0.031
VXLA2500210D	2100	0.040	0.031
VXLA2500270D	2700	0.035	0.015
VXLA2500330D	3300	0.035	0.015
VXLA2500370D	3700	0.035	0.015
VXLA2500450D	4500	0.030	0.015
VXLA2500560D	5600	0.025	0.015
VXLA2500620D	6200	0.025	0.015
VXLA2500740D	7400	0.020	0.015
VXLA2500820D	8200	0.020	0.015

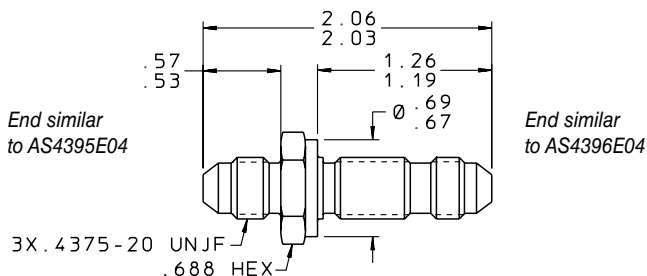

## MATERIALS

PART	MATERIAL	SPECIFICATION
Fitting	304 Cres	AMS QQ-S-763
Stack Retainer	303 Cres	QQ-S-763C
Spacers	303 Cres	QQ-S-763C
Shims	303 Cres	QQ-S-763C
Spinner Discs	17-7PH Cres	AMS 5528
Metering Discs	17-7PH Cres	AMS 5529
Screens	303 Cres	QQ-S-763C
	304L Cres	ASTM A 666
Pin	17-4PH Cres	AMS 5643
Braze	—	AMS 4774

*Finish: All Cres Parts Passivated.*

## PERFORMANCE

Lohm Rate Tolerance .....	±5%
Maximum Working Pressure .....	3000 psid
Proof Pressure .....	6000 psi
Nominal Weight .....	40.0 grams

LEE PART NUMBER	LOHM RATE	MIN. PASSAGE SIZE (Inches)	NOM. SCREEN HOLE SIZE (Inches)
VXLA2501112D	1 120	0.060	0.031
VXLA2501140D	1 400	0.060	0.031
VXLA2501190D	1 900	0.050	0.031
VXLA2501270D	2 700	0.045	0.031
VXLA2501320D	3 200	0.040	0.031
VXLA2501480D	4 800	0.035	0.015
VXLA2501620D	6 200	0.030	0.015
VXLA2501740D	7 400	0.025	0.015
VXLA2501840D	8 400	0.025	0.015
VXLA2501980D	9 800	0.020	0.015
VXLA2501110H	11 000	0.020	0.015

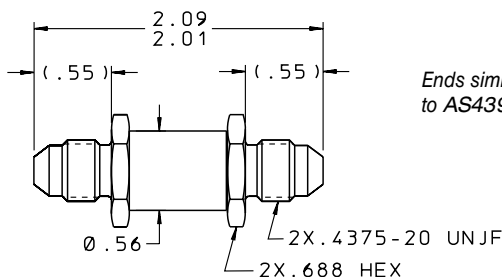

Ends similar  
to AS4395E04

MATERIALS		
PART	MATERIAL	SPECIFICATION
Fittings	304L Cres	AMS 5647
Visco Stack	304L Cres	ASTM A 666
Screens	304L Cres	ASTM A 666
	304L Cres	ASTM A580 / 580M
Screen Spacers	304L Cres	AMS 5647
Shims	304L Cres	ASTM A 666 & AMS 5647
Housing	304L Cres	AMS 5647
Braze	—	AMS 4774

Finish: All Cres Parts Passivated.

PERFORMANCE	
Lohm Rate Tolerance.....	±5%
Maximum Working Pressure.....	3000 psid
Proof Pressure.....	6000 psi
Nominal Weight.....	41.1 grams

LEE PART NUMBER	LOHM RATE	MIN. PASSAGE SIZE (Inches)	NOM. SCREEN HOLE SIZE (Inches)
VDLA4336500D	5 000	0.031	0.020
VDLA4336700D	7 000	0.031	0.020
VDLA4326250H	25 000	0.015	0.010
VDLA4326326H	32 600	0.015	0.010
VDLA4326460H	46 000	0.015	0.010
VDLA4326565H	56 500	0.015	0.010
VDLA4326650H	65 000	0.015	0.010
VDLA4326730H	73 000	0.015	0.010
VDLA4316950K	950 000	0.005	0.002
VDLA4316135T	1 350 000	0.005	0.002
VDLA4316220T	2 200 000	0.005	0.002

Ends similar  
to AS4395E04

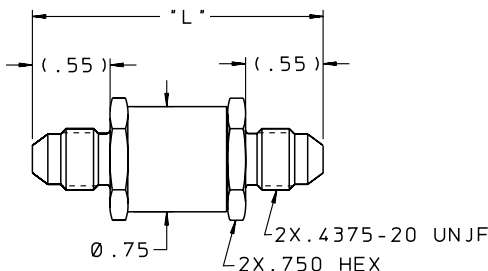

MATERIALS		
PART	MATERIAL	SPECIFICATION
Fittings	304L Cres	AMS 5647
Visco Stack	304L Cres	ASTM A 666
Screens	304L Cres	ASTM A 666
Screen Spacers	304L Cres	AMS 5647
Shims	304L Cres	ASTM A 666 & AMS 5647
Housing	304L Cres	AMS 5647
Braze	—	AMS 4774

Finish: All Cres Parts Passivated.

PERFORMANCE	
Lohm Rate Tolerance.....	±5%
Maximum Working Pressure.....	3000 psid
Proof Pressure .....	6000 psi
Nominal Weight .....	80.0 grams

LEE PART NUMBER	LOHM RATE	"L" DIM. (Inches)	MINIMUM PASSAGE SIZE (Inches)	NOMINAL SCREEN HOLE SIZE (Inches)
VDLA6826137D	1 370	2.04	0.062	No Screen
VDLA6826181D	1 810	2.26	0.062	No Screen
VDLA6816880D	8 800	2.04	0.032	0.020
VDLA6816124H	12 400	2.04	0.032	0.020
VDLA6816152H	15 200	2.26	0.032	0.020
VDLA6816176H	17 600	2.26	0.032	0.020
VDLA6816196H	19 600	2.37	0.032	0.020



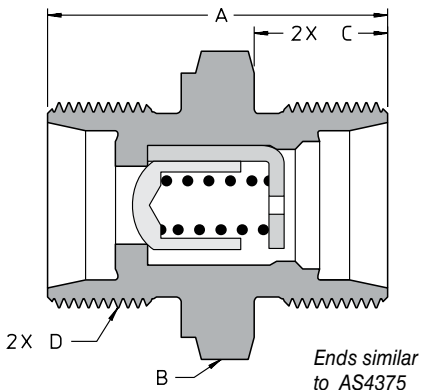

DIMENSIONS				
TUBE SIZE	A	B	C	D
08	1.500	1.000	.56	.750-16UNJF-3A
12	1.750	1.375	.69	1.0625-12UNJ-3A
16	2.125	1.625	.69	1.3125-12UNJ-3A

MATERIALS		
PART	MATERIAL	SPECIFICATION
Fitting	316 Cres	AMS 5648
Poppet	440C	AMS 5630
Spring	17-7PH Cres	AMS 5678
Retainer	13-8 MO Cres	AMS 5629
Cage	304 Cres	ASTM A 666

Finish: All Cres Parts Passivated.

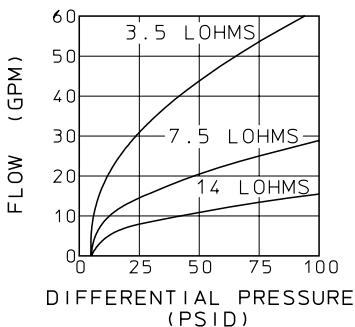

PERFORMANCE		
LEE PART NUMBER	TUBE SIZE	LOHM RATE
CKBC0500605A	08	14
CKBC0750605A	12	7.5
CKBC1000605A	16	3.5

Cracking Pressure ..... 5 ± 3 psid  
 Maximum Leakage in ..... 1 drop/minute at 5 psid  
     checked direction           1 drop/hour at 1000-4000 psid  
 Maximum Working Pressure ..... 4 000 psid  
 Proof Pressure ..... 8 000 psi  
 Burst Pressure ..... 16 000 psi

*Valve Performance on MIL-PRF-83282 at 85°F. 1 drop = 50 µL*

Adapter  
similar to  
AS4383-06-04

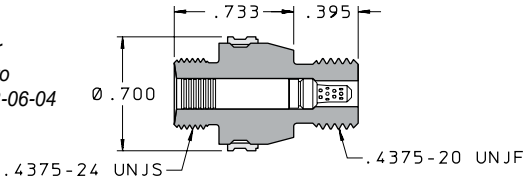

## MATERIALS

PART	MATERIAL	SPECIFICATION
Body	304L Cres	AMS QQ-S-763
Pin	17-4PH Cres	AMS 5643
Spacers	303 Cres	QQ-S-763C
Screen (VHCK)	304L Cres	ASTM A 666
Screen (JHHK)	440C Cres	QQ-S-763
Screen (JHBK)	303 Cres	QQ-S-763C
Screen (JHTK)	304L Cres	ASTM A 666
Metering Element	15-5PH Cres	AMS 5659
VHCK	304L Cres	ASTM A 666
JHHK	304L Cres	QQ-S-763
JHBK	17-7PH Cres	AMS 5529
Adapter	6AL-4V Ti	AMS 4928, AMS 4965, or AMS 4967
Lockring	A286 Cres	AMS 5731, AMS 5732, AMS 5734, AMS 5737, or AMS 5853

Finish: All Cres Parts Passivated. Adapter finish per AMS 2488 Type 2 and/or AS5272. Lockring coated with Blue PTFE and passivated.

## PERFORMANCE

Lohm Rate Tolerance.....	±5%
Maximum Working Pressure .....	5 000 psid
Proof Pressure ....	10 000 psi      Burst Pressure .... 20 000 psi

VISCO JET PART NUMBER	LOHM RATE ±5%	MIN. PASSAGE SIZE (Inches)	NOM. SCREEN HOLE SIZE (Inches)
VHCK0604112H	11 200	0.015	0.008
VHCK0604162H	16 200	0.015	0.008
VHCK0604176H	17 600	0.010	0.006
VHCK0604240H	24 000	0.010	0.006
VHCK0604330H	33 000	0.010	0.006
VHCK0604410H	41 000	0.010	0.006
VHCK0604800H	80 000	0.007	0.004
VHCK0604145K	145 000	0.005	0.004
VHCK0604198K	198 000	0.005	0.004
VHCK0604243K	243 000	0.005	0.004
VHCK0604280K	280 000	0.005	0.004
VHCK0604313K	313 000	0.005	0.004

# In Ring Locked Adapters

21

HIWATT JET PART NUMBER	LOHM RATE ±5%	NOMINAL SCREEN HOLE SIZE (Inches)
JHHK0604350L	350	0.024
JHHK0604375L	375	0.024
JHHK0604400L	400	0.024
JHHK0604425L	425	0.024
JHHK0604450L	450	0.024
JHHK0604475L	475	0.024
JHHK0604500L	500	0.024
JHHK0604550L	550	0.020
JHHK0604600L	600	0.020
JHHK0604650L	650	0.020
JHHK0604700L	700	0.020
JHHK0604750L	750	0.020
JHHK0604800L	800	0.015
JHHK0604850L	850	0.015
JHHK0604900L	900	0.015
JHHK0604950L	950	0.015
JHHK0604100D	1000	0.015
JHHK0604110D	1100	0.012
JHHK0604120D	1200	0.012
JHHK0604130D	1300	0.012
JHHK0604140D	1400	0.012
JHHK0604150D	1500	0.012
JHHK0604160D	1600	0.012
JHHK0604170D	1700	0.012
JHHK0604180D	1800	0.012
JHHK0604190D	1900	0.012
JHHK0604200D	2000	0.012
JHHK0604220D	2200	0.008
JHHK0604240D	2400	0.008
JHHK0604260D	2600	0.008
JHHK0604280D	2800	0.008
JHHK0604300D	3000	0.008

BENDER JET PART NUMBER	LOHM RATE ± 5%	MIN. PASSAGE SIZE (Inches)	NOM. SCREEN HOLE SIZE (Inches)
JHBK0604190D	1900	0.030	0.020
JHBK0604240D	2400	0.030	0.020
JHBK0604330D	3300	0.025	0.015
JHBK0604370D	3700	0.020	0.015
JHBK0604500D	5000	0.020	0.015
JHBK0604590D	5900	0.020	0.015
JHBK0604710D	7100	0.015	0.008
JHBK0604950D	9500	0.015	0.008

L

<b>LEE 5K JET PART NUMBER</b>	<b>LOHM RATE <math>\pm 5\%</math></b>	<b>NOMINAL SCREEN HOLE SIZE (Inches)</b>
JHTK0604100D	1 000	0.008
JHTK0604110D	1 100	0.008
JHTK0604120D	1 200	0.008
JHTK0604130D	1 300	0.008
JHTK0604140D	1 400	0.008
JHTK0604150D	1 500	0.008
JHTK0604160D	1 600	0.008
JHTK0604170D	1 700	0.008
JHTK0604180D	1 800	0.008
JHTK0604190D	1 900	0.008
JHTK0604200D	2 000	0.008
JHTK0604220D	2 200	0.008
JHTK0604240D	2 400	0.008
JHTK0604260D	2 600	0.008
JHTK0604280D	2 800	0.008
JHTK0604300D	3 000	0.008
JHTK0604320D	3 200	0.008
JHTK0604340D	3 400	0.008
JHTK0604360D	3 600	0.008
JHTK0604380D	3 800	0.008
JHTK0604400D	4 000	0.008
JHTK0604430D	4 300	0.008

LEE 5K JET PART NUMBER	LOHM RATE $\pm 5\%$	NOMINAL SCREEN HOLE SIZE (Inches)
JHTK0604460D	4 600	0.008
JHTK0604500D	5 000	0.008
JHTK0604550D	5 500	0.006
JHTK0604600D	6 000	0.006
JHTK0604650D	6 500	0.006
JHTK0604700D	7 000	0.006
JHTK0604750D	7 500	0.006
JHTK0604800D	8 000	0.006
JHTK0604850D	8 500	0.006
JHTK0604900D	9 000	0.006
JHTK0604950D	9 500	0.006
JHTK0604100H	10 000	0.006
JHTK0604110H	11 000	0.004
JHTK0604120H	12 000	0.004
JHTK0604130H	13 000	0.004
JHTK0604140H	14 000	0.004
JHTK0604150H	15 000	0.004
JHTK0604160H	16 000	0.004
JHTK0604170H	17 000	0.004
JHTK0604180H	18 000	0.004
JHTK0604190H	19 000	0.004
JHTK0604200H	20 000	0.004

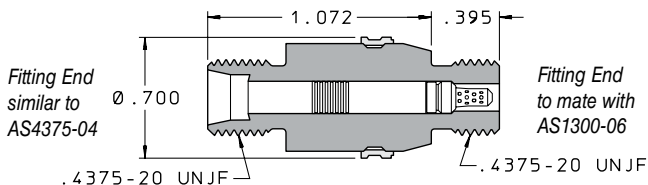

## MATERIALS

PART	MATERIAL	SPECIFICATION
Body	304L Cres	AMS QQ-S-763
Pin	17-4PH Cres	AMS 5643
Spacers	303 Cres	QQ-S-763C
Screen (VHCL)	304L Cres	ASTM A 666
Screen (JHHL)	440C Cres	QQ-S-763
Screen (JHBL)	303 Cres	QQ-S-763C
Screen (JHTL)	304L Cres	ASTM A 666
Metering Element	15-5PH Cres	AMS 5659
VHCL	304L Cres	QQ-S-766
JHHL	304L Cres	AMS QQ-S-763
JHBL	17-7PH Cres	AMS 5529
Adapter	6AL-4V Ti	AMS 4928, AMS 4965, or AMS 4967
Lockring	A286 Cres	AMS 5731, AMS 5732, AMS 5734, AMS 5737, or AMS 5853

Finish: All Cres Parts Passivated. Adapter finish per AMS 2488 Type 2 and/or AS5272. Lockring coated with Blue PTFE and passivated.

## PERFORMANCE

Lohm Rate Tolerance .....	±5%
Maximum Working Pressure .....	4 000 psid
Proof Pressure .....	8 000 psi
Burst Pressure .....	16 000 psi

VISCO JET PART NUMBER	LOHM RATE ± 5%	MIN. PASSAGE SIZE (Inches)	NOM. SCREEN HOLE SIZE (Inches)
VHCL0604112H	11 200	0.015	0.008
VHCL0604162H	16 200	0.015	0.008
VHCL0604176H	17 600	0.010	0.006
VHCL0604240H	24 000	0.010	0.006
VHCL0604330H	33 000	0.010	0.006
VHCL0604410H	41 000	0.010	0.006
VHCL0604800H	80 000	0.007	0.004
VHCL0604145K	145 000	0.005	0.004
VHCL0604198K	198 000	0.005	0.004
VHCL0604243K	243 000	0.005	0.004
VHCL0604280K	280 000	0.005	0.004
VHCL0604313K	313 000	0.005	0.004

# In Ring Locked Adapters

25

HIWATT JET PART NUMBER	LOHM RATE ±5%	NOMINAL SCREEN HOLE SIZE (Inches)
JHHL0604350L	350	0.024
JHHL0604375L	375	0.024
JHHL0604400L	400	0.024
JHHL0604425L	425	0.024
JHHL0604450L	450	0.024
JHHL0604475L	475	0.024
JHHL0604500L	500	0.024
JHHL0604550L	550	0.020
JHHL0604600L	600	0.020
JHHL0604650L	650	0.020
JHHL0604700L	700	0.020
JHHL0604750L	750	0.020
JHHL0604800L	800	0.015
JHHL0604850L	850	0.015
JHHL0604900L	900	0.015
JHHL0604950L	950	0.015
JHHL0604100D	1000	0.015
JHHL0604110D	1100	0.012
JHHL0604120D	1200	0.012
JHHL0604130D	1300	0.012
JHHL0604140D	1400	0.012
JHHL0604150D	1500	0.012
JHHL0604160D	1600	0.012
JHHL0604170D	1700	0.012
JHHL0604180D	1800	0.012
JHHL0604190D	1900	0.012
JHHL0604200D	2000	0.012
JHHL0604220D	2200	0.008
JHHL0604240D	2400	0.008
JHHL0604260D	2600	0.008
JHHL0604280D	2800	0.008
JHHL0604300D	3000	0.008

BENDER JET PART NUMBER	LOHM RATE ± 5%	MIN. PASSAGE SIZE (Inches)	NOM. SCREEN HOLE SIZE (Inches)
JHBL0604190D	1900	0.030	0.020
JHBL0604240D	2400	0.030	0.020
JHBL0604330D	3300	0.025	0.015
JHBL0604370D	3700	0.020	0.015
JHBL0604500D	5000	0.020	0.015
JHBL0604590D	5900	0.020	0.015
JHBL0604710D	7100	0.015	0.008
JHBL0604950D	9500	0.015	0.008

L

LEE 5K JET PART NUMBER	LOHM RATE $\pm 5\%$	NOMINAL SCREEN HOLE SIZE (Inches)
JHTL0604100D	1 000	0.008
JHTL0604110D	1 100	0.008
JHTL0604120D	1 200	0.008
JHTL0604130D	1 300	0.008
JHTL0604140D	1 400	0.008
JHTL0604150D	1 500	0.008
JHTL0604160D	1 600	0.008
JHTL0604170D	1 700	0.008
JHTL0604180D	1 800	0.008
JHTL0604190D	1 900	0.008
JHTL0604200D	2 000	0.008
JHTL0604220D	2 200	0.008
JHTL0604240D	2 400	0.008
JHTL0604260D	2 600	0.008
JHTL0604280D	2 800	0.008
JHTL0604300D	3 000	0.008
JHTL0604320D	3 200	0.008
JHTL0604340D	3 400	0.008
JHTL0604360D	3 600	0.008
JHTL0604380D	3 800	0.008
JHTL0604400D	4 000	0.008
JHTL0604430D	4 300	0.008

LEE 5K JET PART NUMBER	LOHM RATE $\pm 5\%$	NOMINAL SCREEN HOLE SIZE (Inches)
JHTL0604460D	4600	0.008
JHTL0604500D	5000	0.008
JHTL0604550D	5500	0.006
JHTL0604600D	6000	0.006
JHTL0604650D	6500	0.006
JHTL0604700D	7000	0.006
JHTL0604750D	7500	0.006
JHTL0604800D	8000	0.006
JHTL0604850D	8500	0.006
JHTL0604900D	9000	0.006
JHTL0604950D	9500	0.006
JHTL0604100H	10000	0.006
JHTL0604110H	11000	0.004
JHTL0604120H	12000	0.004
JHTL0604130H	13000	0.004
JHTL0604140H	14000	0.004
JHTL0604150H	15000	0.004
JHTL0604160H	16000	0.004
JHTL0604170H	17000	0.004
JHTL0604180H	18000	0.004
JHTL0604190H	19000	0.004
JHTL0604200H	20000	0.004

Adapter similar to MA2119-10-06

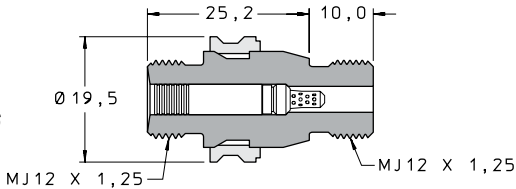

MATERIALS		
PART	MATERIAL	SPECIFICATION
Body	304L Cres	AMS QQ-S-763
Pin	17-4PH Cres	AMS 5643
Spacers	303 Cres	QQ-S-763C
Screen (VHCJ)	304L Cres	ASTM A 666
Screen (JHHJ)	440C Cres	QQ-S-763
Screen (JHBJ)	303 Cres	QQ-S-763C
	304L Cres	ASTM A 666
Screen (JHTJ)	15-5PH Cres	AMS 5659
Metering Element		
VHCJ	304L Cres	QQ-S-766
JHHJ	304L Cres	AMS QQ-S-763
JHBJ	17-7PH Cres	AMS 5529
Adapter	6AL-4V Ti	AMS 4928, AMS 4965, or AMS 4967
Lockring	A286 Cres	AMS 5731, AMS 5732, AMS 5734, AMS 5737, or AMS 5853

Finish: All Cres Parts Passivated. Adapter finish per AMS 2488 Type 2 and/or AS5272. Lockring coated with Blue PTFE and passivated.

PERFORMANCE	
Lohm Rate Tolerance .....	±5%
Maximum Working Pressure .....	28 MPa (diff.)
Proof Pressure .....	56 MPa
Burst Pressure .....	112 MPa

VISCO JET PART NUMBER	LOHM RATE ± 5%	MIN. PASSAGE SIZE (mm)	NOM. SCREEN HOLE SIZE (mm)
VHCJ1206112H	11 200	0,38	0,20
VHCJ1206162H	16 200	0,38	0,20
VHCJ1206176H	17 600	0,25	0,15
VHCJ1206240H	24 000	0,25	0,15
VHCJ1206330H	33 000	0,25	0,15
VHCJ1206410H	41 000	0,25	0,15
VHCJ1206800H	80 000	0,18	0,10
VHCJ1206145K	145 000	0,13	0,10
VHCJ1206198K	198 000	0,13	0,10
VHCJ1206243K	243 000	0,13	0,10
VHCJ1206280K	280 000	0,13	0,10
VHCJ1206313K	313 000	0,13	0,10

HIWATT JET PART NUMBER	LOHM RATE ±5%	NOMINAL SCREEN HOLE SIZE (mm)
JHHJ1206350L	350	0,61
JHHJ1206375L	375	0,61
JHHJ1206400L	400	0,61
JHHJ1206425L	425	0,61
JHHJ1206450L	450	0,61
JHHJ1206475L	475	0,61
JHHJ1206500L	500	0,61
JHHJ1206550L	550	0,51
JHHJ1206600L	600	0,51
JHHJ1206650L	650	0,51
JHHJ1206700L	700	0,51
JHHJ1206750L	750	0,51
JHHJ1206800L	800	0,38
JHHJ1206850L	850	0,38
JHHJ1206900L	900	0,38
JHHJ1206950L	950	0,38
JHHJ1206100D	1000	0,38
JHHJ1206110D	1100	0,30
JHHJ1206120D	1200	0,30
JHHJ1206130D	1300	0,30
JHHJ1206140D	1400	0,30
JHHJ1206150D	1500	0,30
JHHJ1206160D	1600	0,30
JHHJ1206170D	1700	0,30
JHHJ1206180D	1800	0,30
JHHJ1206190D	1900	0,30
JHHJ1206200D	2000	0,30
JHHJ1206220D	2200	0,20
JHHJ1206240D	2400	0,20
JHHJ1206260D	2600	0,20
JHHJ1206280D	2800	0,20
JHHJ1206300D	3000	0,20

BENDER JET PART NUMBER	LOHM RATE ± 5%	MIN. PASSAGE SIZE (mm)	NOM. SCREEN HOLE SIZE (mm)
JHBJ1206190D	1900	0,76	0,51
JHBJ1206240D	2400	0,76	0,51
JHBJ1206330D	3300	0,64	0,38
JHBJ1206370D	3700	0,51	0,38
JHBJ1206500D	5000	0,51	0,38
JHBJ1206590D	5900	0,51	0,38
JHBJ1206710D	7100	0,38	0,20
JHBJ1206950D	9500	0,38	0,20

LEE 5K JET PART NUMBER	LOHM RATE $\pm 5\%$	NOMINAL SCREEN HOLE SIZE (mm)
JHTJ1206100D	1 000	0,20
JHTJ1206110D	1 100	0,20
JHTJ1206120D	1 200	0,20
JHTJ1206130D	1 300	0,20
JHTJ1206140D	1 400	0,20
JHTJ1206150D	1 500	0,20
JHTJ1206160D	1 600	0,20
JHTJ1206170D	1 700	0,20
JHTJ1206180D	1 800	0,20
JHTJ1206190D	1 900	0,20
JHTJ1206200D	2 000	0,20
JHTJ1206220D	2 200	0,20
JHTJ1206240D	2 400	0,20
JHTJ1206260D	2 600	0,20
JHTJ1206280D	2 800	0,20
JHTJ1206300D	3 000	0,20
JHTJ1206320D	3 200	0,20
JHTJ1206340D	3 400	0,20
JHTJ1206360D	3 600	0,20
JHTJ1206380D	3 800	0,20
JHTJ1206400D	4 000	0,20
JHTJ1206430D	4 300	0,20

LEE 5K JET PART NUMBER	LOHM RATE $\pm 5\%$	NOMINAL SCREEN HOLE SIZE (mm)
JHTJ1206460D	4600	0,20
JHTJ1206500D	5000	0,20
JHTJ1206550D	5500	0,15
JHTJ1206600D	6000	0,15
JHTJ1206650D	6500	0,15
JHTJ1206700D	7000	0,15
JHTJ1206750D	7500	0,15
JHTJ1206800D	8000	0,15
JHTJ1206850D	8500	0,15
JHTJ1206900D	9000	0,15
JHTJ1206950D	9500	0,15
JHTJ1206100H	10000	0,15
JHTJ1206110H	11000	0,10
JHTJ1206120H	12000	0,10
JHTJ1206130H	13000	0,10
JHTJ1206140H	14000	0,10
JHTJ1206150H	15000	0,10
JHTJ1206160H	16000	0,10
JHTJ1206170H	17000	0,10
JHTJ1206180H	18000	0,10
JHTJ1206190H	19000	0,10
JHTJ1206200H	20000	0,10

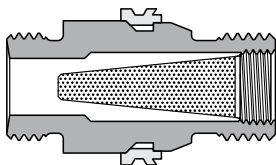

DYNAMIC BEAM SEAL

PERFORMANCE				
LEE PART NUMBER PREFIX	TUBE SIZE	LOHM RATE	HOLE SIZES (Inches)	FOR ADDITIONAL INFO. SEE PAGE
<b>INCH SIZES</b>				
FSIK0604	04	40	0.002, 0.003	I116
		35	0.004, 0.006, 0.008, 0.015, 0.020	
FSIK0806	06	25	0.002, 0.003	I117
		20	0.004, 0.006, 0.008, 0.015, 0.020	
FSIK1008	08	11	0.002, 0.003	I118
		10	0.004, 0.006, 0.008, 0.015, 0.020	
FSIK1210	10	9	0.002, 0.003	I119
		8	0.004, 0.006, 0.008, 0.015, 0.020	
<b>METRIC SIZES</b>				
FSIJ 1206	06	40	0.002, 0.003	I128
		35	0.004, 0.006, 0.008, 0.015, 0.020	
FSIJ1208	08	40	0.002, 0.003	I129
		35	0.004, 0.006, 0.008, 0.015, 0.020	
FSIJ1610	10	25	0.002, 0.003	I130
		20	0.004, 0.006, 0.008, 0.015, 0.020	
FSIJ1812	12	11	0.002, 0.003	I131
		10	0.004, 0.006, 0.008, 0.015, 0.020	
FSIJ2014	14	11	0.002, 0.003	I132
		10	0.004, 0.006, 0.008, 0.015, 0.020	
FSIJ2216	16	9	0.002, 0.003	I133
		8	0.004, 0.006, 0.008, 0.015, 0.020	

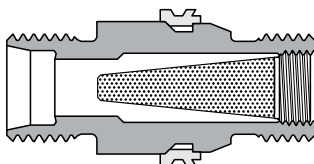

**FLARELESS TUBE**

<b>PERFORMANCE</b>				
<b>LEE PART NUMBER PREFIX</b>	<b>TUBE SIZE</b>	<b>LOHM RATE</b>	<b>HOLE SIZES (Inches)</b>	<b>FOR ADDITIONAL INFO. SEE PAGE</b>
<b>INCH SIZES</b>				
FSIL0604	04	40	0.002, 0.003	I120
		35	0.004, 0.006, 0.008, 0.015, 0.020	
FSIL0806	06	25	0.002, 0.003	I121
		20	0.004, 0.006, 0.008, 0.015, 0.020	
FSIL1008	08	11	0.002, 0.003	I122
		10	0.004, 0.006, 0.008, 0.015, 0.020	
FSIL1210	10	9	0.002, 0.003	I123
		8	0.004, 0.006, 0.008, 0.015, 0.020	
FSIP0404	04	95	0.002, 0.003	I124
		85	0.004, 0.006, 0.008, 0.015, 0.020	
FSIP0606	06	40	0.002, 0.003	I125
		35	0.004, 0.006, 0.008, 0.015, 0.020	
FSIP0808	08	25	0.002, 0.003	I126
		20	0.004, 0.006, 0.008, 0.015, 0.020	
FSIP1010	10	11	0.002, 0.003	I127
		10	0.004, 0.006, 0.008, 0.015, 0.020	

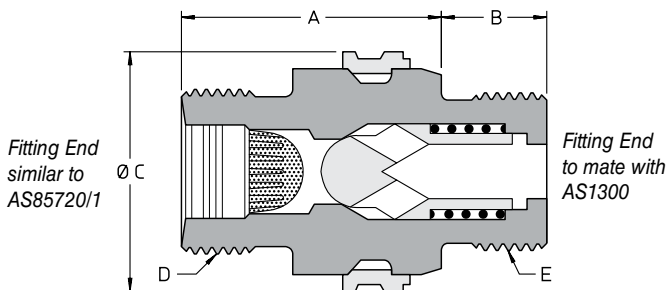

DIMENSIONS					
TUBE SIZE	A	B	C	D	E
04	.743	.380	.700	.4375 -	.4375 -
	.728			24UNJS	20UNJF
06	.988	.415	.814	.5625 -	.5625 -
	.973			20UNJS	18UNJF
08	1.132	.465	1.040	.7188 -	.6875 -
				20UNJS	24UNJEF
10	1.358	.527	1.170	.8438 -	.8125 -
				18UNJS	20UNJEF

MATERIALS		
PART	MATERIAL	SPECIFICATION
Spring Seat	6AL-4V Ti	AMS 4967
Spring	17-7PH Cres	AMS 5678
Poppet	15-5PH Cres	AMS 5659
Screen Body	304L Cres	AMS QQ-S-763
Screen	304L Cres or 410 Cres	ASTM A 666 QQ-S-763C
Braze	—	AMS 4774
Pin	17-4PH Cres	AMS 5643
Adapter	6AL-4V Ti	AMS 4928, AMS 4965, or AMS 4967
Lockring	A286 Cres	AMS 5731, AMS 5732, AMS 5734, AMS 5737, or AMS 5853

*Finish: All Cres Parts Passivated.*

*Adapter finish per AMS 2488 Type 2 and/or AS5272.*

*Lockring coated with Blue PTFE and passivated.*

## UNSCREENED

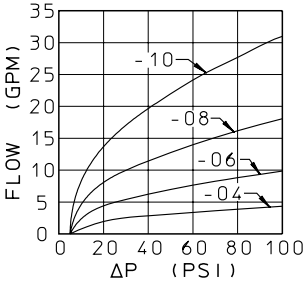

## SCREENED

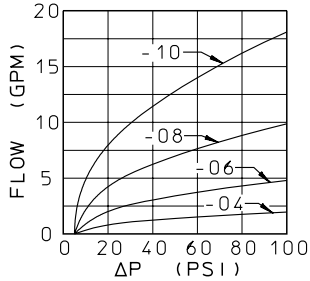

## PERFORMANCE

LEE PART NUMBER	TUBE SIZE	MAX. LOHM RATE	SCREEN OPEN AREA IN. <sup>2</sup> (Nom.)	SCREEN REMOVAL TOOL PART NUMBER
CIFK0604315D	04	150	0.03	CUTA1900328C
CIFK0604060L	04	60	No Screen	
CIFK0806350L	06	50	0.06	CUTA3030328C
CIFK0806027L	06	27	No Screen	
CIFK1008322L	08	22	0.09	CUTA4040328C
CIFK1008013L	08	13	No Screen	
CIFK1210313L	10	13	0.12	CUTA5030328C
CIFK1210008L	10	8	No Screen	

Cracking Pressure ..... 5 ± 3 psid  
 Maximum Leakage in ..... 1 drop/minute at 5 psid  
     checked direction                      1 drop/hour at 1000-5000 psid  
 Nominal Screen Hole Size..... 0 .008"  
 Maximum Working Pressure ..... 5000 psid  
 Proof Pressure ..... 10 000 psi  
 Burst Pressure ..... 20 000 psi

Screen Installation/Extraction Procedures see *Pages N26 – N30*

Valve Performance on MIL-PRF-83282 at 85°F. 1 drop = 50 μL



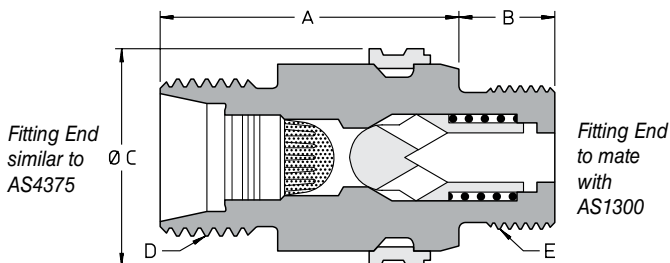

## DIMENSIONS

TUBE SIZE	A	B	C	D	E
04	.968	.395	.700	.4375 - 20UNJF	.4375 - 20UNJF
06	1.184	.430	.814	.5625 - 18UNJF	.5625 - 18UNJF
08	1.428	.465	1.040	.7500 - 16UNJF	.6875 - 24UNJEF
10	1.712	.527	1.170	.8750 - 14UNJF	.8125 - 20UNJEF

## MATERIALS

PART	MATERIAL	SPECIFICATION
Spring Seat	6AL-4V Ti	AMS 4967
Spring	17-7PH Cres	AMS 5678
Poppet	15-5PH Cres	AMS 5659
Screen Body	304L Cres	AMS QQ-S-763
Screen	304L Cres or 410 Cres	ASTM A 666 QQ-S-763C
Braze	—	AMS 4774
Pin	17-4PH Cres	AMS 5643
Adapter	6AL-4V Ti	AMS 4928, AMS 4965, or AMS 4967
Lockring	A286 Cres	AMS 5731, AMS 5732, AMS 5734, AMS 5737, or AMS 5853

*Finish: All Cres Parts Passivated.*

*Adapter finish per AMS 2488 Type 2 and/or AS5272.*

*Lockring coated with Blue PTFE and passivated.*

## UNSCREENED

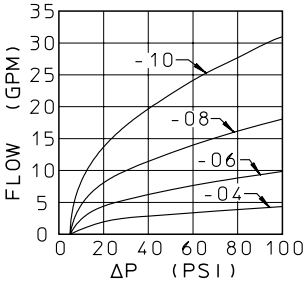

## SCREENED

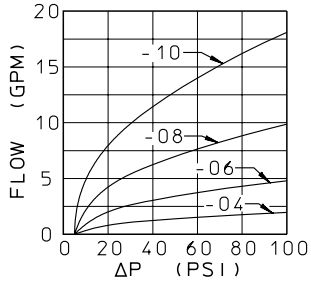

## PERFORMANCE

LEE PART NUMBER	TUBE SIZE	MAX. LOHM RATE	SCREEN OPEN AREA IN. <sup>2</sup> (Nom.)	SCREEN REMOVAL TOOL PART NUMBER
CIFL0604315D	04	150	0.03	CUTA1900328C
CIFL0604060L	04	60	No Screen	
CIFL0806350L	06	50	0.06	CUTA3030328C
CIFL0806027L	06	27	No Screen	
CIFL1008322L	08	22	0.09	CUTA4040328C
CIFL1008013L	08	13	No Screen	
CIFL1210313L	10	13	0.12	CUTA5030328C
CIFL1210008L	10	8	No Screen	

Cracking Pressure ..... 5 ± 3 psid  
 Maximum Leakage in ..... 1 drop/minute at 5 psid  
     checked direction ..... 1 drop/hour at 1000-4000 psid  
 Nominal Screen Hole Size..... 0.008"  
 Maximum Working Pressure ..... 4000 psid  
 Proof Pressure ..... 8000 psi  
 Burst Pressure ..... 16 000 psi

Screen Installation/Extraction Procedures see *Pages N26 – N30*  
 Valve Performance on MIL-PRF-83282 at 85°F. 1 drop = 50 μL

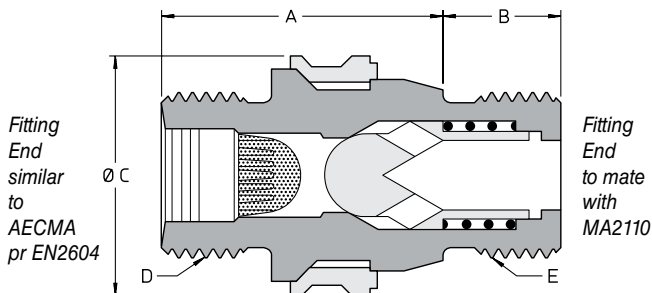

**DIMENSIONS**

TUBE SIZE	A	B	C	D	E
06	25,2	10,0	19,5	MJ12X1,25	MJ12X1,25
08	27,0	10,0	19,5	MJ14X1,5	MJ12X1,25
10	27,0	11,3	22,6	MJ16X1,5	MJ16X1,5
14	36,0	12,7	28,0	MJ20X1,5	MJ20X1,5

**MATERIALS**

PART	MATERIAL	SPECIFICATION
Spring Seat	6AL-4V Ti	AMS 4967
Spring	17-7PH Cres	AMS 5678
Poppet	15-5PH Cres	AMS 5659
Screen Body	304L Cres	AMS QQ-S-763
Screen	304L Cres or 410 Cres	ASTM A 666 QQ-S-763C
Braze	—	AMS 4774
Pin	17-4PH Cres	AMS 5643
Adapter	6AL-4V Ti	AMS 4928, AMS 4965, or AMS 4967
Lockring	A286 Cres	AMS 5731, AMS 5732, AMS 5734, AMS 5737, or AMS 5853

*Finish: All Cres Parts Passivated.*

*Adapter finish per AMS 2488 Type 2 and/or AS5272.*

*Lockring coated with Blue PTFE and passivated.*



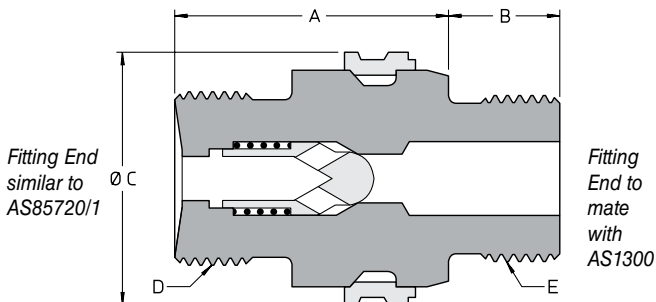

### DIMENSIONS

TUBE SIZE	A	B	C	D	E
06	.980	.430	.814	.5625 - 20UNJS	.5625 - 18UNJF
08	1.132	.465	1.040	.7188 - 20UNJS	.6875 - 24UNJEF
10	1.358	.527	1.170	.8438 - 18UNJS	.8125 - 20UNJEF

### MATERIALS

PART	MATERIAL	SPECIFICATION
Spring Seat	6AL-4V Ti	AMS 4967
Spring	17-7PH Cres	AMS 5678
Poppet	15-5PH Cres	AMS 5659
Adapter	6AL-4V Ti	AMS 4928, AMS 4965, or AMS 4967
Lockring	A286 Cres	AMS 5731, AMS 5732, AMS 5734, AMS 5737, or AMS 5853

*Finish: All Cres Parts Passivated.*

*Adapter finish per AMS 2488 Type 2 and/or AS5272.*

*Lockring coated with Blue PTFE and passivated.*

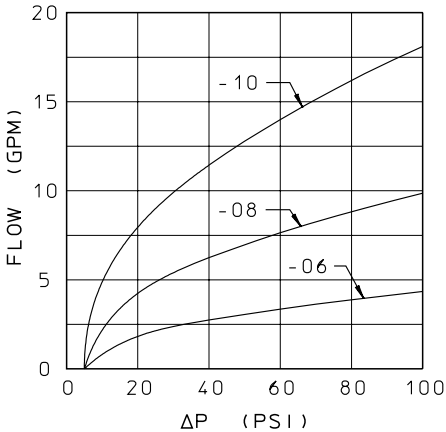

PERFORMANCE		
LEE PART NUMBER	TUBE SIZE	MAX. LOHM RATE
CIRK0806060L	06	60
CIRK1008027L	08	27
CIRK1210013L	10	13
Cracking Pressure ..... 5 ± 3 psid Maximum Leakage in ..... 1 drop/minute at 5 psid checked direction           1 drop/hour at 1000-5000 psid Maximum Working Pressure ..... 5000 psid Proof Pressure ..... 10 000 psi Burst Pressure ..... 20 000 psi  <i>Valve Performance on MIL-PRF-83282 at 85°F. 1 drop = 50 μL</i>		



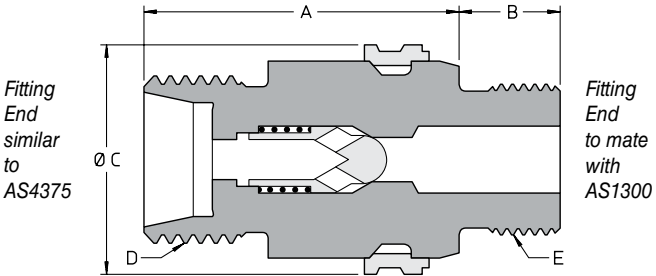

### DIMENSIONS

TUBE SIZE	A	B	C	D	E
06	1.184	.430	.814	.5625 - 18UNJF	.5625 - 18UNJF
08	1.428	.465	1.040	.7500 - 16UNJF	.6875 - 24UNJEF
10	1.712	.527	1.170	.8750 - 14UNJF	.8125 - 20UNJEF

### MATERIALS

PART	MATERIAL	SPECIFICATION
Spring Seat	6AL-4V Ti	AMS 4967
Spring	17-7PH Cres	AMS 5678
Poppet	15-5PH Cres	AMS 5659
Adapter	6AL-4V Ti	AMS 4928, AMS 4965, or AMS 4967
Lockring	A286 Cres	AMS 5731, AMS 5732, AMS 5734, AMS 5737, or AMS 5853

*Finish: All Cres Parts Passivated.*

*Adapter finish per AMS 2488 Type 2 and/or AS5272.*

*Lockring coated with Blue PTFE and passivated.*

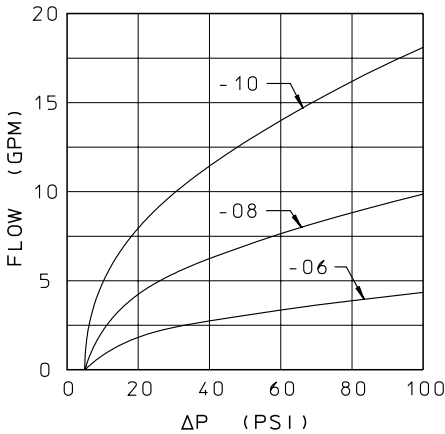

PERFORMANCE		
LEE PART NUMBER	TUBE SIZE	MAX. LOHM RATE
CIRL0806060L	06	60
CIRL1008027L	08	27
CIRL1210013L	10	13
Cracking Pressure ..... $5 \pm 3$ psid Maximum Leakage in ..... 1 drop/minute at 5 psid checked direction           1 drop/hour at 1000-4000 psid Maximum Working Pressure ..... 4000 psid Proof Pressure ..... 8000 psi Burst Pressure ..... 16 000 psi  Valve Performance on MIL-PRF-83282 at 85°F. 1 drop = 50 $\mu$ L		

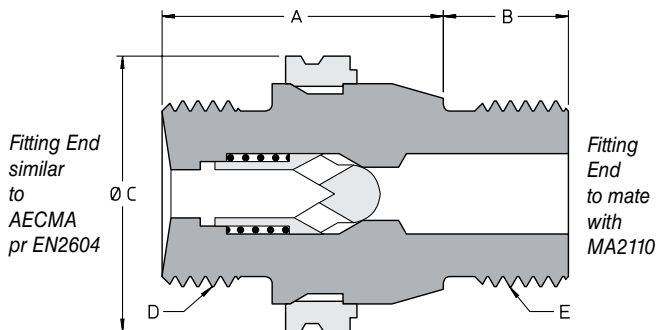

DIMENSIONS					
TUBE SIZE	A	B	C	D	E
08	27,0	10,0	19,5	MJ14X1,5	MJ12X1,25
12	27,0	12,0	26,4	MJ18X1,5	MJ18X1,5
16	38,4	13,4	30,2	MJ22X1,5	MJ22X1,5

MATERIALS		
PART	MATERIAL	SPECIFICATION
Spring Seat	6AL-4V Ti	AMS 4967
Spring	17-7PH Cres	AMS 5678
Poppet	15-5PH Cres	AMS 5659
Adapter	6AL-4V Ti	AMS 4928, AMS 4965, or AMS 4967
Lockring	A286 Cres	AMS 5731, AMS 5732, AMS 5734, AMS 5737, or AMS 5853

Finish: All Cres Parts Passivated.

Adapter finish per AMS 2488 Type 2 and/or AS5272.

Lockring coated with Blue PTFE and passivated.

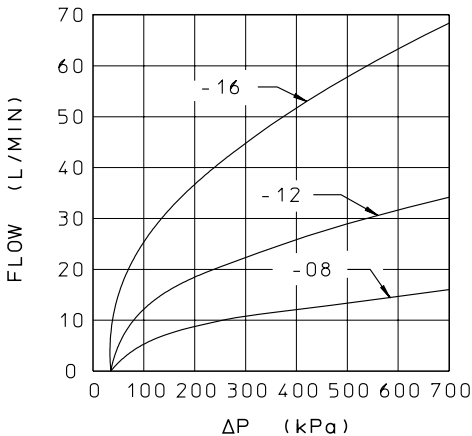

PERFORMANCE		
LEE PART NUMBER	TUBE SIZE	MAX. LOHM RATE
CIRJ1208060L	08	60
CIRJ1812027L	12	27
CIRJ2216013L	16	13

Cracking Pressure ..... 35 ± 20 kPa  
 Maximum Leakage in ..... 1 drop/minute at 35 kPa (diff.)  
     checked direction           1 drop/hour at 7-28 MPa (diff.)  
 Maximum Working Pressure ..... 28 MPa (diff.)  
 Proof Pressure ..... 56 MPa  
 Burst Pressure ..... 112 MPa

*Valve Performance on MIL-PRF-83282 at 29°C. 1 drop = 50 μL*

Fitting End similar to AS85720/1

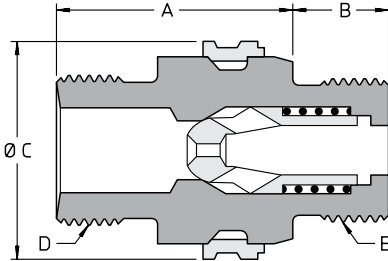

Fitting End to mate with AS1300

DIMENSIONS					
TUBE SIZE	A	B	C	D	E
06	.980	.430	.814	.5625 - 20UNJS	.5625 - 18UNJF
08	1.132	.465	1.040	.7188 - 20UNJS	.6875 - 24UNJEF
10	1.358	.527	1.170	.8438 - 18UNJS	.8125 - 20UNJEF

MATERIALS		
PART	MATERIAL	SPECIFICATION
Spring Seat	6AL-4V Ti	AMS 4967
Spring	17-7PH Cres	AMS 5678
Poppet	15-5PH Cres	AMS 5659
Adapter	6AL-4V Ti	AMS 4928, AMS 4965, or AMS 4967
Lockring	A286 Cres	AMS 5731, AMS 5732, AMS 5734, AMS 5737, or AMS 5853

Finish: All Cres Parts Passivated.  
 Adapter finish per AMS 2488 Type 2 and/or AS5272.  
 Lockring coated with Blue PTFE and passivated.

PERFORMANCE	
Cracking Pressure .....	.5 ± 3 psid
Metered Lohm Rate Tolerance.....	±5%
Maximum Working Pressure .....	.5000 psid
Proof Pressure .....	10 000 psi
Burst Pressure .....	20 000 psi

TUBE SIZE	LEE PART NUMBER	METERED LOHM RATE ( $\pm 5\%$ )	MAX. FREE FLOW LOHM RATE	
06	FCFK0806070L	70	27	
	FCFK0806080L	80	27	
	FCFK0806095L	95	27	
	FCFK0806110L	110	27	
	FCFK0806130L	130	27	
	FCFK0806150L	150	27	
	FCFK0806175L	175	27	
	FCFK0806200L	200	27	
	FCFK0806230L	230	27	
	FCFK0806260L	260	27	
	08	FCFK1008040L	40	13
		FCFK1008045L	45	13
FCFK1008050L		50	13	
FCFK1008055L		55	13	
FCFK1008060L		60	13	
FCFK1008070L		70	13	
FCFK1008080L		80	13	
FCFK1008095L		95	13	
FCFK1008110L		110	13	
FCFK1008130L		130	13	
FCFK1008150L		150	13	
FCFK1008175L		175	13	
FCFK1008200L		200	13	
FCFK1008230L		230	13	
FCFK1008260L		260	13	
10	FCFK1210015L	15	8	
	FCFK1210020L	20	8	
	FCFK1210025L	25	8	
	FCFK1210030L	30	8	
	FCFK1210035L	35	8	
	FCFK1210040L	40	8	
	FCFK1210045L	45	8	
	FCFK1210050L	50	8	
	FCFK1210055L	55	8	
	FCFK1210060L	60	8	
	FCFK1210070L	70	8	
	FCFK1210080L	80	8	
	FCFK1210095L	95	8	
	FCFK1210110L	110	8	
	FCFK1210130L	130	8	
FCFK1210150L	150	8		

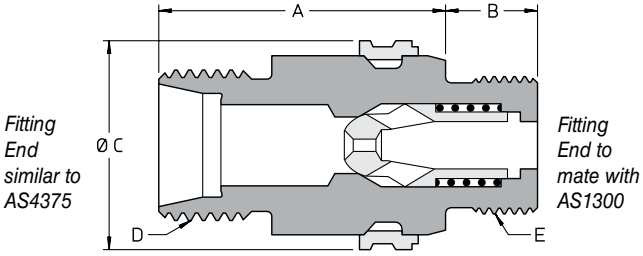

DIMENSIONS					
TUBE SIZE	A	B	C	D	E
06	1.184	.430	.814	.5625 - 18UNJF	.5625 - 18UNJF
08	1.428	.465	1.040	.7500 - 16UNJF	.6875 - 24UNJEF
10	1.712	.527	1.170	.8750 - 14UNJF	.8125 - 20UNJEF

MATERIALS		
PART	MATERIAL	SPECIFICATION
Spring Seat	6AL-4V Ti	AMS 4967
Spring	17-7PH Cres	AMS 5678
Poppet	15-5PH Cres	AMS 5659
Adapter	6AL-4V Ti	AMS 4928, AMS 4965, or AMS 4967
Lockring	A286 Cres	AMS 5731, AMS 5732, AMS 5734, AMS 5737, or AMS 5853

*Finish: All Cres Parts Passivated.  
 Adapter finish per AMS 2488 Type 2 and/or AS5272.  
 Lockring coated with Blue PTFE and passivated.*

PERFORMANCE	
Cracking Pressure .....	5 ± 3 psid
Metered Lohm Rate Tolerance.....	±5%
Maximum Working Pressure .....	4000 psid
Proof Pressure .....	8000 psi
Burst Pressure .....	16 000 psi

TUBE SIZE	LEE PART NUMBER	METERED LOHM RATE ( $\pm 5\%$ )	MAX. FREE FLOW LOHM RATE	
06	FCFL0806070L	70	27	
	FCFL0806080L	80	27	
	FCFL0806095L	95	27	
	FCFL0806110L	110	27	
	FCFL0806130L	130	27	
	FCFL0806150L	150	27	
	FCFL0806175L	175	27	
	FCFL0806200L	200	27	
	FCFL0806230L	230	27	
	FCFL0806260L	260	27	
	08	FCFL1008040L	40	13
		FCFL1008045L	45	13
FCFL1008050L		50	13	
FCFL1008055L		55	13	
FCFL1008060L		60	13	
FCFL1008070L		70	13	
FCFL1008080L		80	13	
FCFL1008095L		95	13	
FCFL1008110L		110	13	
FCFL1008130L		130	13	
FCFL1008150L		150	13	
FCFL1008175L		175	13	
FCFL1008200L		200	13	
FCFL1008230L		230	13	
FCFL1008260L		260	13	
10	FCFL1210015L	15	8	
	FCFL1210020L	20	8	
	FCFL1210025L	25	8	
	FCFL1210030L	30	8	
	FCFL1210035L	35	8	
	FCFL1210040L	40	8	
	FCFL1210045L	45	8	
	FCFL1210050L	50	8	
	FCFL1210055L	55	8	
	FCFL1210060L	60	8	
	FCFL1210070L	70	8	
	FCFL1210080L	80	8	
	FCFL1210095L	95	8	
	FCFL1210110L	110	8	
	FCFL1210130L	130	8	
	FCFL1210150L	150	8	

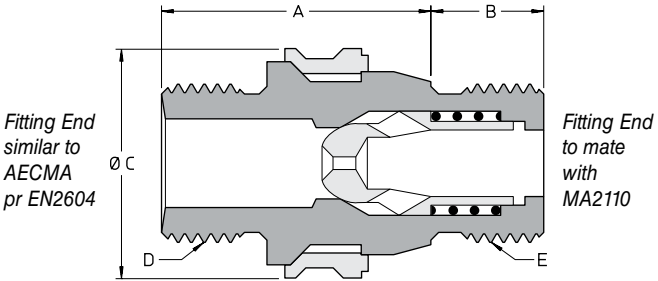

DIMENSIONS					
TUBE SIZE	A	B	C	D	E
10	27,0	11,3	22,6	MJ16X1,5	MJ16X1,5
14	36,0	12,7	28,0	MJ20X1,5	MJ20X1,5

MATERIALS		
PART	MATERIAL	SPECIFICATION
Spring Seat	6AL-4V Ti	AMS 4967
Spring	17-7PH Cres	AMS 5678
Poppet	15-5PH Cres	AMS 5659
Adapter	6AL-4V Ti	AMS 4928, AMS 4965, or AMS 4967
Lockring	A286 Cres	AMS 5731, AMS 5732, AMS 5734, AMS 5737, or AMS 5853

*Finish: All Cres Parts Passivated.*

*Adapter finish per AMS 2488 Type 2 and/or AS5272.*

*Lockring coated with Blue PTFE and passivated.*

PERFORMANCE	
Cracking Pressure .....	35± 20 kPa
Metered Lohm Rate Tolerance.....	±5%
Maximum Working Pressure .....	28 MPa (diff.)
Proof Pressure .....	56 MPa
Burst Pressure .....	112 MPa

# In Ring Locked Adapters

51

TUBE SIZE	LEE PART NUMBER	METERED LOHM RATE ( $\pm 5\%$ )	MAX. FREE FLOW LOHM RATE
10	FCFJ1610040L	40	13
	FCFJ1610045L	45	13
	FCFJ1610050L	50	13
	FCFJ1610055L	55	13
	FCFJ1610060L	60	13
	FCFJ1610070L	70	13
	FCFJ1610080L	80	13
	FCFJ1610095L	95	13
	FCFJ1610110L	110	13
	FCFJ1610130L	130	13
	FCFJ1610150L	150	13
	FCFJ1610175L	175	13
	FCFJ1610200L	200	13
	FCFJ1610230L	230	13
	FCFJ1610260L	260	13
14	FCFJ2014015L	15	8
	FCFJ2014020L	20	8
	FCFJ2014025L	25	8
	FCFJ2014030L	30	8
	FCFJ2014035L	35	8
	FCFJ2014040L	40	8
	FCFJ2014045L	45	8
	FCFJ2014050L	50	8
	FCFJ2014055L	55	8
	FCFJ2014060L	60	8
	FCFJ2014070L	70	8
	FCFJ2014080L	80	8
	FCFJ2014095L	95	8
	FCFJ2014110L	110	8
	FCFJ2014130L	130	8
FCFJ2014150L	150	8	

L

# Pressure Components

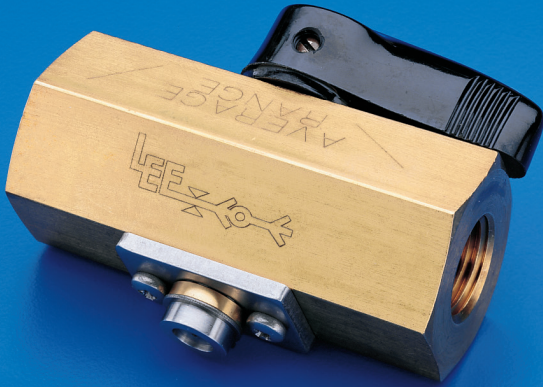

M

## LEE MICRO DAMP

- Microminiature
- Damps Pressure Transients
- Extends Life of Gauges, Switches and Transducers

## HYDAMP

- Damps Pressure Spikes
- Allows Gauge to Read Maximum, Minimum or Average Pressure



- Records Peak Pressure
- Simple to Remove and Read
- Inconel Construction

## TABLE OF CONTENTS

<b>Micro Damp</b>	Miniature restrictor (Visco Jet) for damping pressure transients .....	3 – 5, 8 – 9
<b>Hydamp</b>	Adjustable pulsation damper .....	6, 10 – 11
<b>Kipster</b>	Peak pressure recorder .....	6 – 7, 12 – 13

## LEE MICRO DAMP

The Lee Visco Jet<sup>®</sup>, 0.125 inches in diameter, has been designed specifically to provide pressure surge protection for hydraulic pressure transmitters, pressure switches and pressure gauges as required by AS 5440.

The Micro Damp operates at system pressures of up to 8000 psid and is so small it can often be incorporated directly into the sensing port of a pressure transducer. The package is only 0.125 inches in diameter and 0.32 to 0.50 inches long, depending on the Lohm rate required. Twelve Lohm rates are offered from 11,200 to 313,000 Lohms, so the designer can properly size the restriction.

The Lee Micro Damp improves the accuracy, reliability, and life of pressure measurement instruments. A pressure transducer, for example, is specified for a particular application based upon a system's maximum operating pressure, with an additional overpressure margin if pressure transients, spikes or pulsations are present. If a pressure transducer is chosen to tolerate the higher pressure transients, then accuracy is sacrificed. The Lee Micro Damp Visco Snubber therefore allows a transducer optimized for a lower pressure range to be used. Also, reliability and life are improved since pressure sensing elements are not fully exposed to the detrimental effects of the pressure spikes. Catastrophic failures due to extreme, unanticipated overpressurization are also avoided. Using the Lohm Law for snubbing on the next page, performance can be accurately predicted, eliminating costly trial and error methods.

# 4

# Pressure Components

## TRANSDUCER SNUBBING

Transducer snubbing need no longer be guesswork. Using our new Lohm law for snubbers it is easy to select the correct Visco snubber for every application.

Typical applications involve snubbing a cyclic pressure ripple superimposed on a steady pressure. The graph on [page M5](#) together with the formula below provide a rapid means of calculating the necessary Lohm rate.

### TO FIND A LOHM RATE

Decide how much attenuation is required and use the graph on [page 5](#) to obtain a value for  $f_o$ . Use this in the formula below and solve for Lohm rate.

$$L = \frac{2.2 f_o}{f_r (K + v/B) \sqrt{P_o}}$$

L = Fluid resistance (Lohms)

$f_o$  = Frequency from graph (Hz)

$f_r$  = Ripple frequency (Hz)

$v^*$  = Internal volume of the transducer ( $\text{in}^3$ )

B = Fluid bulk modulus (psi)

$K^*$  = Transducer compliance ( $\text{in}^3/\text{psi}$ )

$P_o$  = Ripple amplitude, peak-to-peak (psi)

\*Obtainable from the transducer manufacturer.

### EXAMPLE

A pressure transducer is being damaged by a pump ripple of 270 Hz. The peak-to-peak amplitude is 1000 psi. Knowing the transducer has an internal volume of  $0.09 \text{ in}^3$  (1.5 mL) and a compliance of  $3 \times 10^{-7} \text{ in}^3/\text{psi}$ , which Visco snubber is required to reduce the ripple to 1/20 of the unsnubbed amplitude? The fluid is Skydrol with a bulk modulus of 340,000 psi.

Obtain  $f_0$  from the graph (170 Hz at 0.05 amplitude ratio.)  
Then use the formula:

$$L = \frac{2.2 \times 170}{270 (3 + 2.6) \times 10^{-7} \times \sqrt{1000}}$$

$$L = 78,200 \text{ Lohms}$$

Use Visco snubber Part Number VHSA1250800H  
(80,000 Lohms).

## ATTENUATION CHART

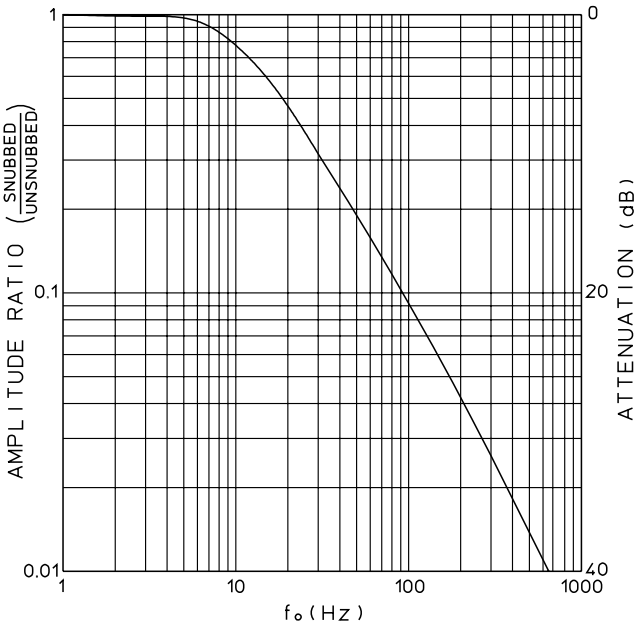

## 6

# Pressure Components

### LEE HYDAMP

The Lee Hydamp is more than just a snubber. It is a multi-function damper that lets you read maximum, minimum or average pressures from an ordinary gauge without costly transducers, amplifiers or recorders.

Simply rotate the selector knob to read minimum pressure through to maximum pressure. In between, read average pressure while varying the damping. Lee Hydamps extend the life of your gauges and are easy to mount.

Hydamps are available in a brass body for pressures up to 6000 psi. There is also a stainless steel version for pressures to 8000 psi.

### LEE KIPSTER

The Kipster is a miniature peak pressure recorder. Each Kipster contains a pressure sensitive disc which permanently and irreversibly deforms a calibrated amount in relation to the peak pressure sensed. By simply measuring the deformation of the disc, the peak pressure can be determined from the deflection versus pressure graph on [page M13](#).

The Kipster is designed to be an economical alternative for recording peak pressures. While its accuracy doesn't replace sophisticated electronics, it does offer unique design opportunities where other expensive and bulky options are inappropriate. The Kipster can be used in a wide range of applications. Typical examples are: water hammer, hydraulic transient pressure rises, and warranty protection, where the Kipster will establish if a maximum operating pressure has been exceeded.

Due to its compact size, the Kipster is capable of being installed in areas not accessible to electronic transducers. The Kipster is even small enough to be installed in a -4 Tee! The Kipster utilizes the patented TWIS mounting system which provides for maximum mounting flexibility. Special mounting methods and custom configurations are also available.

## **PRESSURE RANGES/ACCURACY**

There are 3 models of pressure recording Kipsters that span the pressure range from 4000 psi to 30,000 psi. The first model is designed to measure pressures in the 4000 to 12,000 psi range and has an accuracy of  $\pm 3\%$  of full scale. The second and third models cover the ranges of 7000 to 21,000 psi and 10,000 to 30,000 psi with an accuracy of  $\pm 2.5\%$  and  $\pm 3\%$  of full scale, respectively.

## **PRESSURIZATION RATES**

The Kipster will record peak pressure rises over a wide range of pressurization rates. Testing has been conducted with nitrogen at slow rates (0.14 psi/sec.), and at higher rates with water (2,000,000 psi/sec.).

The rate of pressurization has little effect on the Kipster's accuracy up to 50,000 psi/sec. Above this rate, some drift can be expected. If a repeatable rate of rise is being monitored, the drift is consistent Kipster to Kipster. This has been experimentally shown to 2,000,000 psi/sec.

PIN

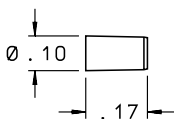

INSERT

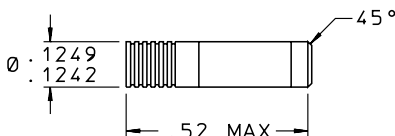

## MATERIALS

PART	MATERIAL	SPECIFICATION
Body	304L Cres	AMS QQ-S-763
Pin	17-4PH Cres	AMS 5643
Visco Stack	304L Cres	ASTM A 666
Spacers	304L Cres	QQ-S-763
Screens	304L Cres	ASTM A 666
Braze	—	AMS 4774

*Finish: All Cres Parts Passivated.*

*Pins are prewaxed. Do not degrease. Do not lubricate.*

## PERFORMANCE

Lohm Rate Tolerance.....	±10%
Maximum Working Pressure.....	8000 psid
Nominal Weight .....	0.4 grams

## NOMINAL SCREEN DATA

DISC STYLE	NOMINAL SCREEN DATA		
	TOTAL AREA (Square Inches)	OPEN AREA (Square Inches)	SCREEN HOLE SIZE (Inches)
VHSA121	0.005	0.0009	0.004
VHSA122	0.005	0.0009	0.004
VHSA123	0.005	0.0009	0.004
VHSA124	0.005	0.0009	0.004

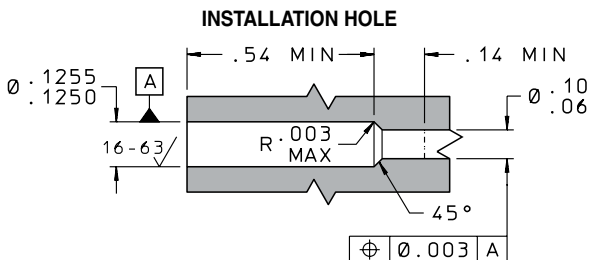

## INSTALLATION AND EXTRACTION

Tool Set Part Number ..... CUTA1250306C  
 Procedures ..... See **Pages N26 – N30**  
*For Boss size see **page N24**. For oversize see **page N27**.*

LEE PART NUMBER	LOHM RATE	MINIMUM PASSAGE SIZE (Inches)
VHSA1240112H	11 200	0.015
VHSA1240162H	16 200	0.015
VHSA1230176H	17 600	0.010
VHSA1230240H	24 000	0.010
VHSA1230330H	33 000	0.010
VHSA1230410H	41 000	0.010
VHSA1220800H	80 000	0.007
VHSA1210145K	145 000	0.005
VHSA1210198K	198 000	0.005
VHSA1210243K	243 000	0.005
VHSA1210280K	280 000	0.005
VHSA1210313K	313 000	0.005

# 10 Hydamp

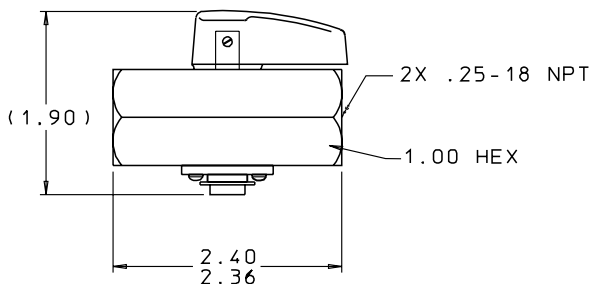

MATERIALS		
PART	MATERIAL	SPECIFICATION
Body *	303 Cres	QQ-S-763C
Body **	360 Brass	QQ-B-626
Shaft	17-4PH Cres	AMS 5643
O-Ring Retainer	301 Cres	QQ-S-766C
O-Rings	VITON	MIL-R-83248/1
Back-up Ring	TEFLON	MS28774
Retaining Ring	Cres	MS16624-4037
Machine Screws	Cres	MS51957-13
Spacer Shim*	416 Cres	QQ-S-763C
Spacer Shim**	360 Brass	QQ-B-626
Knob	PHENOLIC	—
Lee Plug**	416 Cres	QQ-S-763C
Lee Plug*	17-4PH Cres	AMS 5643
187 Lee Chek**	(see pg. E8)	—
125 Lee Chek*	(see pg. E58)	—

\* Cres version only

\*\*Brass version only

*Finish: All Cres Parts Passivated.*

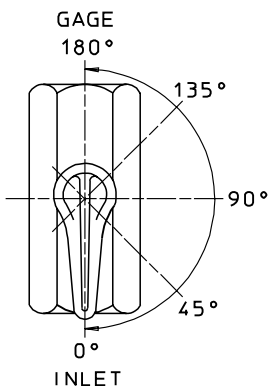

0° ..... MINIMUM PRESSURE

45° ..... AVERAGE PRESSURE  
(Maximum Damping)

90° ..... AVERAGE PRESSURE  
(Minimum Damping)

135° ..... AVERAGE PRESSURE  
(Maximum Damping)

180° ..... MAXIMUM PRESSURE

LEE PART NUMBER	BODY MATERIAL	MAXIMUM WORKING PRESSURE (psid)	MAXIMUM TRANSIENT PRESSURE (psi)	BURST PRESSURE (psi)
HYDA5412215T	Brass	6000	6750	10000
HYDA5420315T	Cres	8000	9600	12000

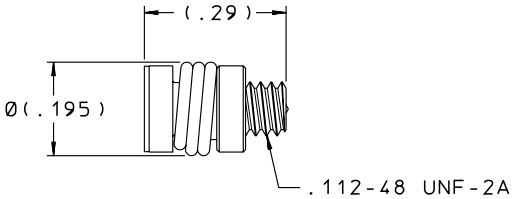

MATERIALS	
PART	MATERIAL
Body and Spring	Cres
Sensing Element	Inconel

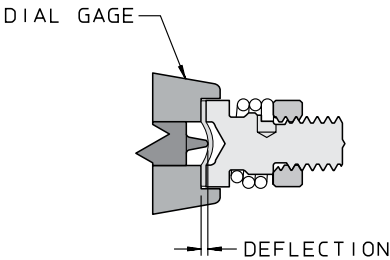

PERFORMANCE			
MODEL	K1	K2	K3
Part Number	KIPA1810112K	KIPA1810221K	KIPA1810330K
Pressure Range (psi)	4 000 - 12 000	7 000 - 21 000	10 000 - 30 000
Accuracy			
±% of full scale	3	2.5	3
± psi	360	525	900

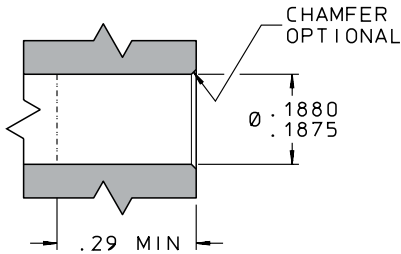

## INSTALLATION AND EXTRACTION

Installation/Extraction Tool Part Number..... RTTA1870100

Dial Gauge and Calibration Block

Tool Set Part Number ..... RTTA1870150

Pressure Measurement Procedures ..... See [Page N41](#)

## KIPSTER DEFLECTION PROFILE

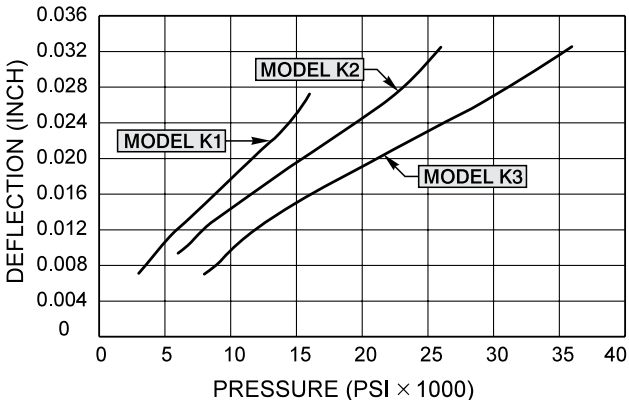



- ❑ **Installation Procedures**
- ❑ **Extraction Procedures**
- ❑ **Tools for Installation and Extraction**
- ❑ **Oversize Part Numbers**
- ❑ **Guidelines for Boss Size**
- ❑ **Adapters for Stacking Inserts**

**TABLE OF CONTENTS**

<b>Lee</b>	Inspection & Handling.....	3
<b>Plugs</b>	Installation.....	4 – 5
	Quick Installation Plug, Installation ..	6 – 7
	Extraction.....	8 – 9
	Oversize & Tool Part Number.....	9 – 14
	Plug Size Charts.....	15 – 16
	R.F.O.....	17 – 20
	A.F.O.....	21 – 23
<b>Lee</b>	Boss Size.....	24
<b>Inserts</b>	Dual Insert Adapter.....	25
	Installation & Extraction .....	26 – 30
	3- Port Inserts .....	31 – 32
<b>Cartridge</b>		
<b>Visco Jets</b>	.....	33 – 36
<b>Lee</b>		
<b>Microjet</b>	.....	37
<b>Safety</b>	L4.....	38 – 39
<b>Screens</b>	Spring Retained .....	40
	TWIS.....	40
<b>Kipster</b>	.....	41

**INSPECTION AND HANDLING**

1. When measuring the O. D. of the Plug, a micrometer should be used on the front or solid end of the Plug to eliminate errors in readings due to permissible groove burrs. Groove burrs are left on the O.D. of Plugs to 0.001" over maximum diameter. This increases the proof pressure.
2. Manufacturing tolerances are closer than those shown for inspection in this handbook. Inspection drawings are freely available for all Lee components.
3. All dimensions are statistically checked. Key dimensions are 100% checked, and all plugs and pins are 100% visually inspected.
4. Lee Plug pins are pre-waxed, and must not be degreased. In addition, Lee Plug sets should not be stored at temperatures exceeding 150°F to avoid wax coating loss. Pin handling should be kept to a minimum.
5. Aluminum Lee Plugs are color coded to assure easy and foolproof identification between the standard size, oversize, and metric plugs. The standard 2024 aluminum plugs are green, the oversize aluminum plugs are red, and the metric aluminum plugs are brown. Standard and oversize stainless steel Lee Plugs are clearly marked on their packaging.
6. All Lee Plugs are manufactured and controlled by lots. These lot numbers are marked on the bags for plugs and pins and correspond to bar material certifications from the mill, which are on file at The Lee Company. In addition, certification of performance testing is included with every shipment of plugs.

**INSTALLATION TOOLS**

The Lee Company offers a complete line of installation tools (see table starting on [page N10](#)).

**PLUG INSTALLATION TOOL****INSTALLATION METHOD**

1. The installation hole and O. D. of the plug should be clean and dry.
2. Insert the plug into the hole until it is firmly seated against the shoulder of the reamed hole.
3. The pins are factory pre-waxed for easy installation. Additional lubrication must not be used.
4. Start the smaller chamfered end of the pin into the tapered hole. Avoid tilting the pin.
5. Firmly support the item to be plugged.
6. Press or drive the pin until the exposed end of the pin is flush with the exposed end of the plug.

## FLUSHNESS TOLERANCES

Long Series Lee Plug		Short Series Lee Plug	
Into Plug	0.010 in.	Into Plug	0.003 in.
Out of Plug	0.005 in.	Out of Plug	0.005 in.

## PRE-ASSEMBLY

It is not advisable to partially insert the Pin into the Plug as a pre-assembly before installing the Plug in the reamed hole. This has a tendency to expand the Plug, and on insertion cause longitudinal scratch marks in the reamed hole, which can cause undesirable leakage.

## INSTALLATION FORCES

1. Lee Plugs are usually a slip fit in the reamed holes. Push fits can be encountered when the hole size is less than the permissible groove burr diameter.
2. Always make sure that the Plug has been inserted firmly against the shoulder of the reamed hole. If this is not done, the Plug may slide forward while the Pin is being driven and cause longitudinal scratch marks in the reamed hole.
3. The work required to expand and lock the Plug comes from the drive force and the distance the Pin is driven. Therefore, on the larger sizes the drive forces are understandably higher.
4. Pins may be driven into the plugs using an arbor press, hydraulic press, or hammer. When using a hammer, a few firm blows is preferable to a series of light taps.

**SEATING TOOL****INSTALLATION TOOL****INSTALLATION METHOD**

The following procedure should be followed when installing Lee Quick Installation Plugs (see figure on [page N7](#)).

1. The installation hole and O.D. of the plug should be clean and dry.
2. Firmly support the item to be plugged.
3. Slip the pre-assembled pin and plug into the hole. **Lightly push or tap** the back of the plug with the seating tool (see table on [page N7](#)) until it is firmly seated on the support shoulder in the mounting hole. This is a technique that will ensure firm seating. If this is not done, the plug may slide forward while the pin is being driven and cause longitudinal scratch marks in the reamed hole. **Do not** apply any more than a few pounds of force to ensure a more firm seat.
4. Press or drive the pin with the proper installation tool (see table on [page N10](#)) until the end of the pin is flush with the end of the plug within the tolerances indicated in the table on [page N5](#) for Short Series Lee Plug.

## INSTALLATION METHOD

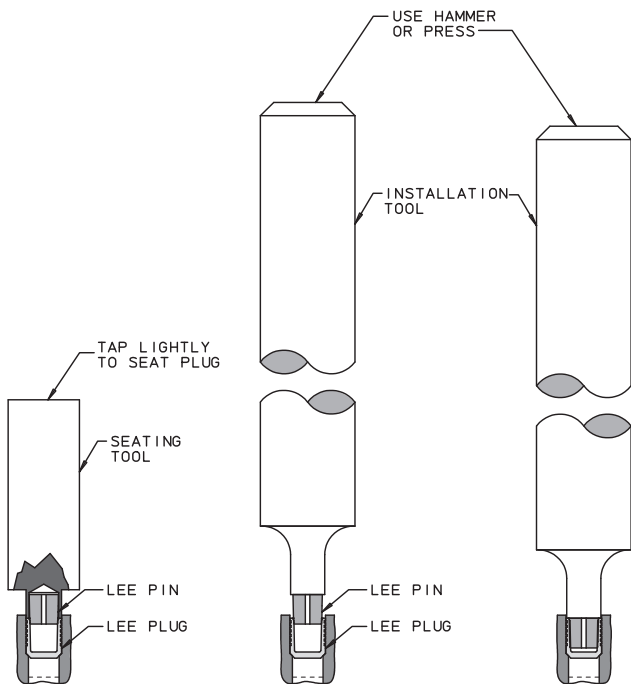

## QUICK INSTALLATION PLUG SEATING TOOLS

LEE PLUG STANDARD PART NUMBER	SEATING TOOL
PLPA0930010A	CUTA0930303A
PLPA1250010A	CUTA1250303A
PLPA1560010A	CUTA1560303A
PLPA1870010A	CUTA1870303A

**EXTRACTION TOOLS**

The design of Lee Plugs ensures permanent leak-tight sealing by controlled expansion. This feature also allows for convenient extraction should access to the internal passageways be required at any time.

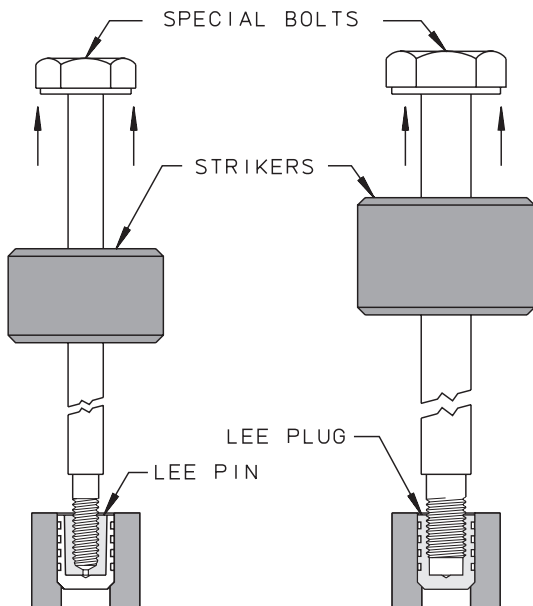

The Lee Company maintains a stock of extraction tools for all sizes of Lee Plugs. Each set is comprised of tap sets for pin and plug, removal bolts for pin and plug, and striker(s) (see table starting on [page N10](#)).

Using the correct tooling will ensure the reamed hole remains undamaged and uncontaminated. Holes should be inspected after Lee Plug extraction, since it is frequently possible to reuse the hole directly without machining to the next oversize. A new pin and plug should always be used.

## EXTRACTION METHOD

1. Drill and tap a hole in the Pin.
2. Extract the Pin using the bolt and striker.
3. Tap the Plug.
4. Extract the Plug using the appropriate bolt and striker.

## OVERSIZE

The Lee Company stocks a full line of Oversize Lee Plugs. These Plugs are for rework or salvage of reamed holes. For each standard inch size there is an oversize Lee Plug which has all of the same dimensions, except the O.D. is 0.010 inch larger than the standard. The proof pressures are the same. The part numbers are shown in the table starting on [page N10](#). When using oversize Lee Plugs, pick the maximum and minimum ream diameters for the appropriate class of fit. Then add 0.010 inch to both the maximum and minimum diameters shown on the tables in [Section A](#).

Metric Lee Plugs provide additional intermediate plug sizes for repair work. The chart on [page N15](#) lists both *inch* and *metric* plug diameters in inches to help in the selection process. The chart on [page N16](#) lists plug diameters in millimeters so that *inch* size plugs can be selected for rework of metric plug holes.

## LEE PLUG PROCESS SPECIFICATION

Details of all the practical aspects of using Lee Plugs are given in our Process Specification 203. Contact The Lee Company for a complimentary copy.

## LEE PLUG VIDEO GUIDE

A complete video guide to installation and extraction of Lee Plugs is available upon request.

## TOOL SET AND OVERSIZE PART NUMBERS

LEE PLUG STANDARD PART NUMBER	LEE PLUG OVERSIZE PART NUMBER	INSTALLATION TOOL PART NUMBER	EXTRACTION TOOL SET PART NUMBER
PLGA0930010A	PLGA1030010A	CUTA0930203A	CUTA0930103B
PLGA0930020A	PLGA1030020A		
PLGA0931010A	PLGA1031010A		
PLGA0931020A	PLGA1031020A		
PLGA0931400A	PLGA1031400A		
PLHA0931241A	PLHA1031241A		
PLPA0930010A	PLGA1030010A		
PLGA1250010A	PLGA1350010A	CUTA1250203A	CUTA1250103B
PLGA1250020A	PLGA1350020A		
PLGA1251010A	PLGA1351010A		
PLGA1251020A	PLGA1351020A		
PLGA1251400A	PLGA1351400A		
PLHA1251241A	PLHA1351241A		
PLPA1250010A	PLGA1350010A		
PLGA1560010A	PLGA1660010A	CUTA1560203A	CUTA1560103B
PLGA1560020A	PLGA1660020A		
PLGA1561010A	PLGA1661010A		
PLGA1561020A	PLGA1661020A		
PLGA1561400A	PLGA1661400A		
PLHA1561241A	PLHA1661241A		
PLPA1560010A	PLGA1660010A		
PLGA1870010A	PLGA1970010A	CUTA1870203A	CUTA1870103B
PLGA1870020A	PLGA1970020A		
PLGA1871010A	PLGA1971010A		
PLGA1871020A	PLGA1971020A		
PLGA1871400A	PLGA1971400A		
PLHA1871241A	PLHA1971241A		
PLPA1870010A	PLGA1970010A		

## TOOL SET AND OVERSIZE PART NUMBERS

LEE PLUG STANDARD PART NUMBER	LEE PLUG OVERSIZE PART NUMBER	INSTALLATION TOOL PART NUMBER	EXTRACTION TOOL SET PART NUMBER
PLGA2180010A PLGA2180020A PLGA2181010A PLGA2181020A PLGA2181400A PLHA2181241A	PLGA2280010A PLGA2280020A PLGA2281010A PLGA2281020A PLGA2281400A PLHA2281241A	CUTA2180203A	CUTA2180103B
PLGA2500010A PLGA2500020A PLGA2501010A PLGA2501020A PLGA2501400A PLHA2501241A	PLGA2600010A PLGA2600020A PLGA2601010A PLGA2601020A PLGA2601400A PLHA2601241A	CUTA2500203A	CUTA2500103B
PLGA2810010A PLGA2810020A PLGA2811010A PLGA2811020A PLGA2811400A PLHA2811241A	PLGA2910010A PLGA2910020A PLGA2911010A PLGA2911020A PLGA2911400A PLHA2911241A	CUTA2810203A	CUTA2810103B
PLGA3120010A PLGA3120020A PLGA3121010A PLGA3121020A PLGA3121400A PLHA3121241A	PLGA3220010A PLGA3220020A PLGA3221010A PLGA3221020A PLGA3221400A PLHA3221241A	CUTA3120203A	CUTA3120103B

## TOOL SET AND OVERSIZE PART NUMBERS

LEE PLUG STANDARD PART NUMBER	LEE PLUG OVERSIZE PART NUMBER	INSTALLATION TOOL PART NUMBER	EXTRACTION TOOL SET PART NUMBER
PLGA3430010A	PLGA3530010A	CUTA3430203A	CUTA3430103B
PLGA3430020A	PLGA3530020A		
PLGA3431010A	PLGA3531010A		
PLGA3431020A	PLGA3531020A		
PLGA3431400A	PLGA3531400A		
PLHA3431241A	PLHA3531241A		
PLGA4060010A	PLGA4160010A	CUTA4060303A	CUTA4060103B
PLGA4060020A	PLGA4160020A		
PLGA4061010A	PLGA4161010A		
PLGA4061020A	PLGA4161020A		
PLGA4061400A	PLGA4161400A		CUTA4060203B
PLGA4680010A	PLGA4780010A	CUTA4680203A	CUTA4680103B
PLGA4680020A	PLGA4780020A		
PLGA4681010A	PLGA4781010A		
PLGA4681020A	PLGA4781020A		
PLGA4681400A	PLGA4781400A		
PLGA5310010A	PLGA5410010A	CUTA5310203A	CUTA5310103B
PLGA5310020A	PLGA5410020A		
PLGA5311010A	PLGA5411010A		
PLGA5311020A	PLGA5411020A		
PLGA5311400A	PLGA5411400A		
PLGA6560010A	PLGA6660010A	CUTA6560203A	CUTA6560103B
PLGA6560020A	PLGA6660020A		
PLGA6561010A	PLGA6661010A		
PLGA6561020A	PLGA6661020A		
PLGA6561400A	PLGA6661400A		

## METRIC LEE PLUG TOOL SET PART NUMBERS

METRIC LEE PLUG PART NUMBER	INSTALLATION TOOL PART NUMBER	EXTRACTION TOOL SET PART NUMBER
PLGM0250010A PLGM0250020A	CUTA0930203A	CUTM0250103B
PLGM0300010A PLGM0300020A	CUTA0930203A	CUTM0300103B
PLGM0350010A PLGM0350020A	CUTA1250203A	CUTM0350103B
PLGM0400010A PLGM0400020A PLGM0401010A PLGM0401020A	CUTA1560203A	CUTM0400103B
PLGM0450010A PLGM0450020A PLGM0451010A PLGM0451020A	CUTA1560203A	CUTM0450103B
PLGM0500010A PLGM0500020A PLGM0501010A PLGM0501020A	CUTA1870203A	CUTM0500103B
PLGM0550010A PLGM0550020A PLGM0551010A PLGM0551020A	CUTA1870203A	CUTM0550103B

**METRIC LEE PLUG  
TOOL SET PART NUMBERS**

<b>METRIC LEE PLUG PART NUMBER</b>	<b>INSTALLATION TOOL PART NUMBER</b>	<b>EXTRACTION TOOL SET PART NUMBER</b>
PLGM0600010A PLGM0600020A PLGM0601010A PLGM0601020A	CUTA2180203A	CUTM0600103B
PLGM0650010A PLGM0650020A PLGM0651010A PLGM0651020A	CUTA2500203A	CUTM0650103B
PLGM0700010A PLGM0700020A PLGM0701010A PLGM0701020A	CUTA2810203A	CUTM0700103B
PLGM0750010A PLGM0750020A PLGM0751010A PLGM0751020A	CUTA2810203A	CUTM0750103B
PLGM0800010A PLGM0800020A PLGM0801010A PLGM0801020A	CUTA3120203A	CUTM0800103B

## COMMON LEE PLUG SIZES (INCHES)

PART NUMBER	REAM DIAMETER (CLASS 3)	"A" MINIMUM	
		SHORT PLUGS	LONG PLUGS
PLGA093 - - - -	0.0937 – 0.0942	0.097	0.145
PLGM025 - - - -	0.0984 – 0.0989	0.107	—
PLGA103 - - - -	0.1037 – 0.1042	0.097	0.145
PLGM030 - - - -	0.1181 – 0.1186	0.123	—
PLGA125 - - - -	0.1250 – 0.1255	0.125	0.195
PLGA135 - - - -	0.1350 – 0.1355	0.125	0.195
PLGM035 - - - -	0.1378 – 0.1383	0.134	—
PLGA156 - - - -	0.1562 – 0.1567	0.130	0.250
PLGM040 - - - -	0.1575 – 0.1580	0.154	0.260
PLGA166 - - - -	0.1662 – 0.1667	0.130	0.250
PLGM045 - - - -	0.1772 – 0.1777	0.170	0.280
PLGA187 - - - -	0.1875 – 0.1880	0.152	0.253
PLGM050 - - - -	0.1968 – 0.1973	0.186	0.300
PLGA197 - - - -	0.1975 – 0.1980	0.152	0.253
PLGM055 - - - -	0.2165 – 0.2170	0.201	0.319
PLGA218 - - - -	0.2187 – 0.2192	0.187	0.312
PLGA228 - - - -	0.2287 – 0.2292	0.187	0.312
PLGM060 - - - -	0.2362 – 0.2367	0.217	0.339
PLGA250 - - - -	0.2500 – 0.2505	0.212	0.352
PLGM065 - - - -	0.2559 – 0.2564	0.237	0.359
PLGA260 - - - -	0.2600 – 0.2605	0.212	0.352
PLGM070 - - - -	0.2756 – 0.2761	0.252	0.378
PLGA281 - - - -	0.2812 – 0.2817	0.250	0.375
PLGA291 - - - -	0.2912 – 0.2917	0.250	0.375
PLGM075 - - - -	0.2953 – 0.2958	0.268	0.398
PLGA312 - - - -	0.3124 – 0.3129	0.269	0.423
PLGM080 - - - -	0.3150 – 0.3155	0.284	0.418
PLGA322 - - - -	0.3224 – 0.3229	0.269	0.423
PLGA343 - - - -	0.3437 – 0.3442	0.295	0.437
PLGA353 - - - -	0.3537 – 0.3542	0.295	0.437
PLGA406 - - - -	0.4062 – 0.4067	0.325	0.500
PLGA416 - - - -	0.4162 – 0.4167	0.325	0.500
PLGA468 - - - -	0.4687 – 0.4692	0.350	0.562
PLGA478 - - - -	0.4787 – 0.4792	0.350	0.562
PLGA531 - - - -	0.5312 – 0.5317	0.486	0.625
PLGA541 - - - -	0.5412 – 0.5417	0.486	0.625
PLGA656 - - - -	0.6562 – 0.6567	0.490	0.685
PLGA666 - - - -	0.6662 – 0.6667	0.490	0.685

Unshaded = "Hard" Dimensions

Shaded = "Soft" Dimensions

## COMMON LEE PLUG SIZES (mm)

PART NUMBER	REAM DIAMETER (CLASS 3)	"A" MINIMUM	
		SHORT PLUGS	LONG PLUGS
PLGA093 ----	2,38 – 2,39	2,5	3,7
PLGM025 ----	2,50 – 2,51	2,7	—
PLGA103 ----	2,635 – 2,645	2,5	3,7
PLGM030 ----	3,00 – 3,01	3,1	—
PLGA125 ----	3,175 – 3,185	3,2	5,0
PLGA135 ----	3,43 – 3,44	3,2	5,0
PLGM035 ----	3,50 – 3,51	3,4	—
PLGA156 ----	3,97 – 3,98	3,4	6,4
PLGM040 ----	4,00 – 4,01	3,9	6,6
PLGA166 ----	4,22 – 4,23	3,4	6,4
PLGM045 ----	4,50 – 4,51	4,3	7,1
PLGA187 ----	4,765 – 4,775	3,9	6,5
PLGM050 ----	5,00 – 5,01	4,7	7,6
PLGA197 ----	5,02 – 5,03	3,9	6,5
PLGM055 ----	5,50 – 5,51	5,1	8,1
PLGA218 ----	5,56 – 5,57	4,8	8,0
PLGA228 ----	5,81 – 5,82	4,8	8,0
PLGM060 ----	6,00 – 6,01	5,5	8,6
PLGA250 ----	6,35 – 6,36	5,4	9,0
PLGM065 ----	6,50 – 6,51	6,0	9,1
PLGA260 ----	6,61 – 6,62	5,4	9,0
PLGM070 ----	7,00 – 7,01	6,4	9,6
PLGA281 ----	7,145 – 7,155	6,4	9,6
PLGA291 ----	7,40 – 7,41	6,4	9,6
PLGM075 ----	7,50 – 7,51	6,8	10,1
PLGA312 ----	7,94 – 7,95	6,9	10,8
PLGM080 ----	8,00 – 8,01	7,2	10,6
PLGA322 ----	8,19 – 8,20	6,9	10,8
PLGA343 ----	8,73 – 8,74	7,5	11,1
PLGA353 ----	8,99 – 9,00	7,5	11,1
PLGA406 ----	10,32 – 10,33	8,3	12,8
PLGA416 ----	10,57 – 10,58	8,3	12,8
PLGA468 ----	11,91 – 11,92	8,9	14,3
PLGA478 ----	12,16 – 12,17	8,9	14,3
PLGA531 ----	13,495 – 13,505	12,4	15,9
PLGA541 ----	13,75 – 13,76	12,4	15,9
PLGA656 ----	16,67 – 16,68	12,5	17,4
PLGA666 ----	16,92 – 16,93	12,5	17,4

Unshaded = "Hard" Dimensions

Shaded = "Soft" Dimensions

# R.F.O. LEE PLUG INSTALLATION

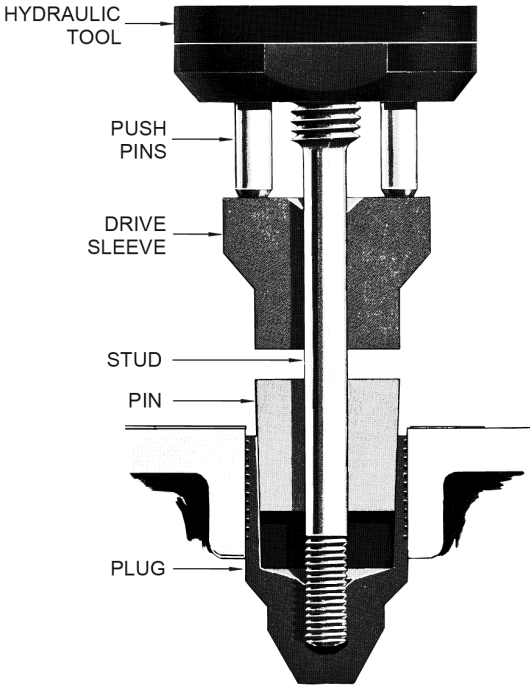

**INSTALLATION METHOD**

R.F.O. Lee Plugs are installed with Lee R.F.O. Hydraulic Installation Tool CUTX0100000B and the appropriate Installation Tool Set (see table, [page N20](#)).

1. Slide the drive sleeve over the stud. Thread the stud completely onto the driving piston.
2. Slide the pin onto the stud with the smaller end of the pin pointing away from the stud.
3. Thread the R. F. O. plug onto the stud approximately 7 turns, until finger tight.
4. Slide the plug into the reamed hole to the desired depth.
5. Operate the hand pump to drive the pin into the plug. Drive the pin until the rear surface of the pin is flush with the back edge of the plug.
6. Release the pump pressure and the piston will retract.
7. To disengage the stud turn the driving piston assembly counterclockwise. The swivel fitting will prevent the hose from twisting.

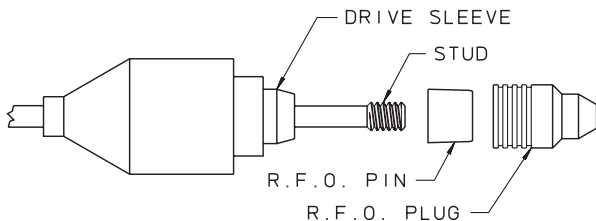

## EXTRACTION METHOD

R.F.O. Lee Plugs can be extracted with Lee R.F.O. Hydraulic Installation Tool CUTX0100000B and the appropriate Extraction Tool Set (see table, [page N20](#)).

1. Select the proper extraction sleeve and stud for the R.F.O. plug being removed.
2. After sliding the extraction sleeve onto the stud, thread the stud into the piston assembly until bottomed snugly.
3. Thread the other end of the stud fully into the R.F.O. pin. The swivel fitting prevents the hose from twisting. For 0.156 inch diameter through 0.260 inch diameter R.F.O.'s, pins must first be threaded using the tap supplied in the extraction tool set.
4. Operate the pump to extract the pin.
5. Thread the bolt, with the striker, fully into the R.F.O. plug and remove the plug by tapping the striker against the bolt head.

## HYDRAULIC INSTALLATION TOOL

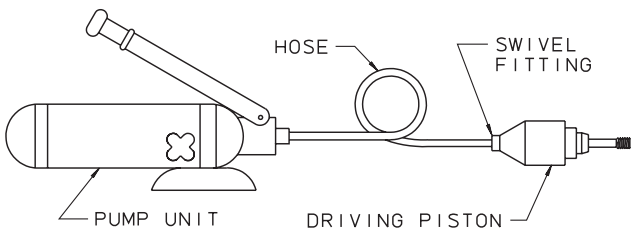

**PART NUMBER: CUTX0100000B**

**R.F.O. PLUG TOOL SET  
AND OVERSIZE PART NUMBERS**

R.F.O. PLUG STANDARD PART NUMBER	R.F.O. PLUG OVERSIZE PART NUMBER	INSTALLATION TOOL SET PART NUMBER	EXTRACTION TOOL SET PART NUMBER
PLRA1560010A	PLRA1660010A	CUTA1565205A	CUTA1566205B
PLRA1870010A	PLRA1970010A	CUTA1875205A	CUTA1876205B
PLRA2180010A	PLRA2280010A	CUTA2185205A	CUTA2186205B
PLRA2500010A	PLRA2600010A	CUTA2505205A	CUTA2506205B
PLRA2810010A	PLRA2910010A	CUTA2815205A	CUTA2816205B
PLRA3430010A	PLRA3530010A	CUTA3435205A	CUTA3436205B
PLRA4060010A	PLRA4160010A	CUTA4065205A	CUTA4066205B
PLRA4680010A	PLRA4780010A	CUTA4685205A	CUTA4686205B
PLRA5000010A	PLRA5100010A	CUTA5005205A	CUTA5006205B
PLRA5310010A	PLRA5410010A	CUTA5315205A	CUTA5316205B
PLRA6560010A	PLRA6660010A	CUTA6565205A	CUTA6566205B
PLRA7500010A	PLRA7600010A	CUTA7505205A	CUTA7506205B
PLRA8750010A	PLRA8850010A	CUTA8755205A	CUTA8756205B

The pump, the hose, the swivel fitting, the gauge and the drive piston assembly can be ordered with part number CUTX0100000B. Order the appropriate installation and extraction tool sets separately.

When using oversize Lee Plugs, pick the maximum and minimum ream diameters for the appropriate class of fit, then add 0.010 inch to both the maximum and minimum diameters shown on the tables in [Section A](#).

## COINING TOOLS

Coining tools are available for each A.F.O. Plug (see table on [page N22](#)).

### A.F.O. PLUG COINING TOOL

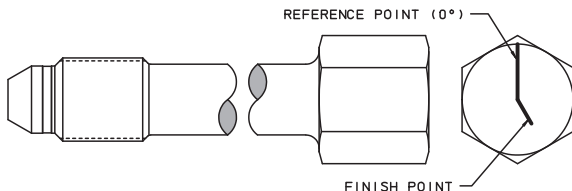

## COINING METHOD

1. Coin the sealing seat using the coining tool listed in the table on [page N22](#).
2. Coining is accomplished by rotating the coining tool to the proper angle listed in the table on [page N22](#). The angle has been calculated to correspond to an even chamfer within the acceptable width.
3. As shown in the figure above, coining tools are marked with two lines on the top face to aid in the measurement of rotation\*. The longer line represents the reference point (0°) and the shorter line indicates the finish point.
4. Thread the tool by hand into the installation hole until the nose bottoms out on the edge to be coined.
5. Mark a line at the finish point on the housing manifold and use a wrench to rotate the tool until the reference line is parallel with the manifold marking. In tougher materials that are difficult to coin, the nose and threads may be coated with a high film strength oil to prevent galling during the coining operation.
6. Check to see that an even chamfer approximately .015 - .025 inches wide was formed. If the chamfer is not wide enough, repeat the coining procedure at a slightly higher angle of rotation and re-inspect the seat.

\* Lee coining tools manufactured prior to November 2018 may not have reference lines.

**COINING TOOLS AND REQUIRED ROTATION**

A.F.O. PLUG PART NUMBER	COINING TOOL PART NUMBER	REQUIRED TOOL ROTATION
PLAA1932010A	CUTA1900163A	200° +/- 45°
PLAA1932020A	CUTA1900163A	200° +/- 45°
PLAA2528010A	CUTA2500163A	175° +/- 35°
PLAA2528020A	CUTA2500163A	175° +/- 35°
PLAA3124010A	CUTA3120163A	150° +/- 30°
PLAA3124020A	CUTA3120163A	150° +/- 30°
PLAA3724010A	CUTA3750163A	150° +/- 30°
PLAA3724020A	CUTA3750163A	150° +/- 30°
PLAA5020010A	CUTA5000163A	125° +/- 25°
PLAA5020020A	CUTA5000163A	125° +/- 25°
PLAA5020110A	CUTA5000263A	125° +/- 25°
PLAA5020120A	CUTA5000263A	125° +/- 25°
PLAA6218010A	CUTA6250163A	110° +/- 25°
PLAA6218020A	CUTA6250163A	110° +/- 25°
PLAA7516010A	CUTA7500163A	100° +/- 20°
PLAA7516020A	CUTA7500163A	100° +/- 20°
PLAA7516110A	CUTA7500263A	100° +/- 20°
PLAA7516120A	CUTA7500263A	100° +/- 20°

## INSTALLATION METHOD

1. Install the A.F.O. Plug by hand until the nose piece is seated against the sealing surface.
2. Tighten the plug to its installation torque value as described in the table below. The A.F.O. Plug may be coated with a high film strength oil on the nose piece and the area between the body and nose.

## TORQUE VALUES

A.F.O. PLUG PART NUMBER	COINING TOOL PART NUMBER	ALUMINUM HOUSING		STAINLESS STEEL / AISI 8630 HOUSING	
		(Ref.) Coining Torque	Installation Torque	(Ref.) Coining Torque	Installation Torque
PLAA1932010A	CUTA1900163A	10 in-lbs	7 in-lbs	22 in-lbs	18 in-lbs
PLAA1932020A	CUTA1900163A	10 in-lbs	7 in-lbs	22 in-lbs	18 in-lbs
PLAA2528010A	CUTA2500163A	30 in-lbs	25 in-lbs	71 in-lbs	55 in-lbs
PLAA2528020A	CUTA2500163A	30 in-lbs	25 in-lbs	71 in-lbs	55 in-lbs
PLAA3124010A	CUTA3120163A	85 in-lbs	75 in-lbs	180 in-lbs	90 in-lbs
PLAA3124020A	CUTA3120163A	85 in-lbs	75 in-lbs	180 in-lbs	90 in-lbs
PLAA3724010A	CUTA3750163A	125 in-lbs	100 in-lbs	275 in-lbs	220 in-lbs
PLAA3724020A	CUTA3750163A	125 in-lbs	100 in-lbs	275 in-lbs	220 in-lbs
PLAA5020010A	CUTA5000163A	25 ft-lbs	25 ft-lbs	40 ft-lbs	30 ft-lbs
PLAA5020020A	CUTA5000163A	25 ft-lbs	25 ft-lbs	40 ft-lbs	30 ft-lbs
PLAA5020110A	CUTA5000263A	25 ft-lbs	25 ft-lbs	40 ft-lbs	30 ft-lbs
PLAA5020120A	CUTA5000263A	25 ft-lbs	25 ft-lbs	40 ft-lbs	30 ft-lbs
PLAA6218010A	CUTA6250163A	40 ft-lbs	40 ft-lbs	95 ft-lbs	55 ft-lbs
PLAA6218020A	CUTA6250163A	40 ft-lbs	40 ft-lbs	95 ft-lbs	55 ft-lbs
PLAA7516010A	CUTA7500163A	50 ft-lbs	50 ft-lbs	95 ft-lbs	75 ft-lbs
PLAA7516020A	CUTA7500163A	50 ft-lbs	50 ft-lbs	95 ft-lbs	75 ft-lbs
PLAA7516110A	CUTA7500263A	50 ft-lbs	50 ft-lbs	95 ft-lbs	75 ft-lbs
PLAA7516120A	CUTA7500263A	50 ft-lbs	50 ft-lbs	95 ft-lbs	75 ft-lbs

**INSERT BOSS SIZE\***

The installation of a Lee insert in a hydraulic manifold with the Lee tapered expander principle produces a high retention force, a leak tight seal, and low stress in the manifold. As with the Lee Plug, alternate lands and grooves on the O.D. of the Lee insert produce local plastic deformation and interlocking with the manifold to form the seals. The discontinuous bands of stress rapidly average out to a uniform stress as we examine the surrounding material. To assure that the stress in the manifold is below 40% of its yield strength (a customary design standard), and to assure maximum retention of the Lee insert, the minimum D/d ratios shown on the graph below should be observed.

MINIMUM RECOMMENDED D/d RATIO  
FOR LEE INSERTS

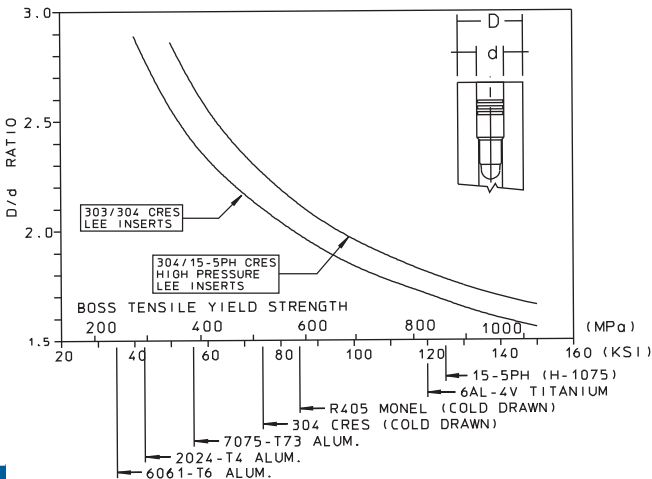

\* See [pages A9-A10](#) for Lee Plug boss size.

## DUAL INSERT ADAPTERS

It is now possible to stack two Lee inserts of the same diameter in series with the use of the Lee Dual Insert Adapter. The Adapter eliminates the need to machine an additional shoulder, which normally would be required to place a second insert behind the first. The second insert is no longer required to be of a larger diameter than the first, allowing for a smaller boss. Machining is simplified, and space and weight are reduced.

Dual Insert Adapters are available for 0.187 inch and 0.281 inch diameter Lee inserts, and are offered in two versions: one with crossport flow capability and the other without. They are not to be used in conjunction with Lee Plugs.

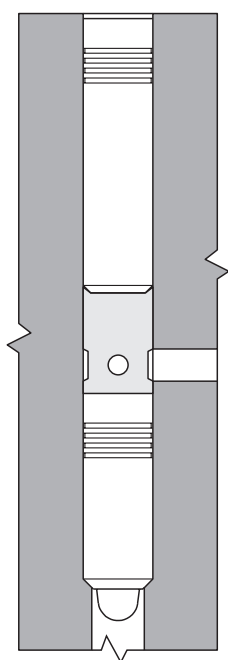

TYPICAL INSTALLATION

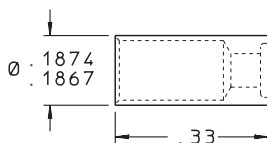

NO CROSSPORT

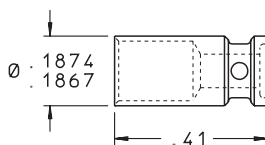

WITH CROSSPORT

## INSTALLATION AND EXTRACTION OF LEE INSERTS

Lee Inserts utilize the principle of controlled expansion which employs a tapered expander pin and a body with an internal taper, and lands and grooves on the outside. When the pin is pressed into the body, the lands “bite” into the surrounding material to seal and lock the insert in place. The body and pin of most inserts have internal threads to facilitate installation and extraction.

The Lee Company provides an installation/extraction tool kit at minimal cost as a service to our customers. The kit contains a body tool, a pin extraction tool, a pin installation tool and a striker.

BODY TOOL

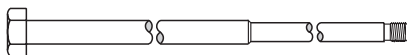

PIN EXTRACTION TOOL

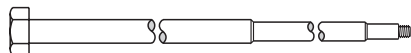

PIN INSTALLATION TOOL



STRIKER

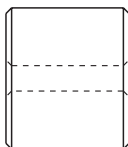

SIDE VIEW

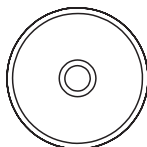

FRONT VIEW

## **INSTALLATION METHOD**

1. Thread the insert body onto the body tool.
2. Push the insert firmly into the reamed hole until it is seated against the 45° shoulder. Remove the body tool.
3. Thread the pin completely onto the pin installation tool.
4. Drive the pin into the body until the pin is flush with the body to within  $\pm 0.005$  inch.

## **EXTRACTION METHOD**

1. Slide the striker onto the pin extraction tool and thread it completely into the pin.
2. Strike the head of the pin extraction tool with the striker until the pin is removed.
3. Repeat steps 1 & 2 using the body bolt and a striker to remove the insert body.

For a more detailed installation and extraction procedure see Process Specification 187 which is available upon request from The Lee Company.

## **REINSTALLATION**

With reasonable care, Lee inserts are reusable without further machining until the fifth or sixth insertion/removal cycle. A new pin should be used for every new installation. When an installation hole is no longer serviceable, re-ream to 0.010 inch over the original size (same depth and same tolerances) and use an oversize insert. An oversize version of all Lee inserts is available. (NOTE: High Pressure inserts can not be reinstalled in aluminum.)

## **OVERSIZE**

To order an oversize part, the part number for the standard size part must be modified to indicate 0.010 inch oversize. The diameter is signified by the first three numbers in the part number, (shown on the next [page](#)).

**EXAMPLES****STANDARD PART NUMBER**

CHFA1256505A  
 JETA1872800L  
 CKFA2506205A  
 PRFA2812080L  
 FCFA3755070L  
 FLFA5001350D

**OVERSIZE PART NUMBER**

CHFA1356505A  
 JETA1972800L  
 CKFA2606205A  
 PRFA2912080L  
 FCFA3855070L  
 FLFA5101350D

When using oversize inserts, add 0.010 inch to both the maximum and minimum diameter of the installation hole. All other dimensions remain the same as the standard size.

BODY DIA. STANDARD/ OVERSIZE	INST./EXTR. TOOL KIT PART NUMBER	PIN		BODY INST./EXTR. THREAD SIZE
		INST. / EXTR.	THREAD SIZE	
0.125 / 0.135	CUTA1250306C	0.073	- 64*	0.112 - 40*
	CUTA1250801C	0.086	- 56*	0.086 - 56*
0.156 / 0.166	CUTA1560104C	0.086	- 64	0.138 - 40
0.187 / 0.197	CUTA1870104C	0.112	- 40	0.164 - 36
	CUTA1870109C	0.112	- 40	0.112 - 40
	CUTA1877000C	0.112	- 40	0.164 - 36
	CUTA1870110C	0.112	- 40	0.125 - 40
	CUTA1870128C	0.112	- 40	0.099 - 48
	CUTA1870210C	0.112	- 40	0.125 - 40
	CUTA1870306C	0.112	- 40	0.164 - 36*
	CUTA1870801C	0.112	- 40*	0.190 - 32 MOD*
	CUTA1870904C	0.086	- 56	0.156 - 36
0.250 / 0.260	CUTA2500106C	0.138	- 40	0.216 - 28
	CUTA2000113C	0.125	- 40	0.125 - 40
	CUTA2500306C	0.164	- 36	0.164 - 36
	CUTA2500406C	0.164	- 36	0.164 - 36
	CUTA2500801C	0.164	- 36*	0.250 - 20 MOD*
0.281 / 0.291	CUTA2810104C	0.164	- 36	0.216 - 28
	CUTA2810114C	0.138	- 40	0.250 - 48
0.343 / 0.353	CUTA3430106C	—		0.125 - 40
0.375 / 0.385	CUTA3750106C	0.250	- 32	0.250 - 32
	CUTA3750114C	0.250	- 32	0.325 - 40
	CUTA3750214C	0.250	- 32	0.325 - 40
	CUTA3750306C	0.250	- 32	0.250 - 32
0.500 / 0.510	CUTA5000106C	0.375	- 24	0.3125 - 24
	CUTA5000116C	0.375	- 24	0.4375 - 28
	CUTA5000206C	0.3125	- 24	0.3125 - 24
	CUTA5000306C	0.375	- 24	0.375 - 24

\* Not threaded. Tool set includes tapset.

## PIN JACKING TOOLS

If the installation hole is not reamed correctly, or the housing material is soft, the body and pin are occasionally extracted as an assembly when trying to remove only the pin. This condition may produce a reamed hole which is unacceptable for reinstallation of Lee Hydraulic Inserts. To eliminate this possibility, The Lee Company also offers pin jacking tools which gently remove the pin by reacting the pin extraction forces on the exposed face of the body, thereby more effectively preserving the integrity of the insert and the reamed hole.

There are two types of pin jacking tools, a T-Handle Pin Jacking Tool and a stud and sleeve set that works with a standard rivet tool.

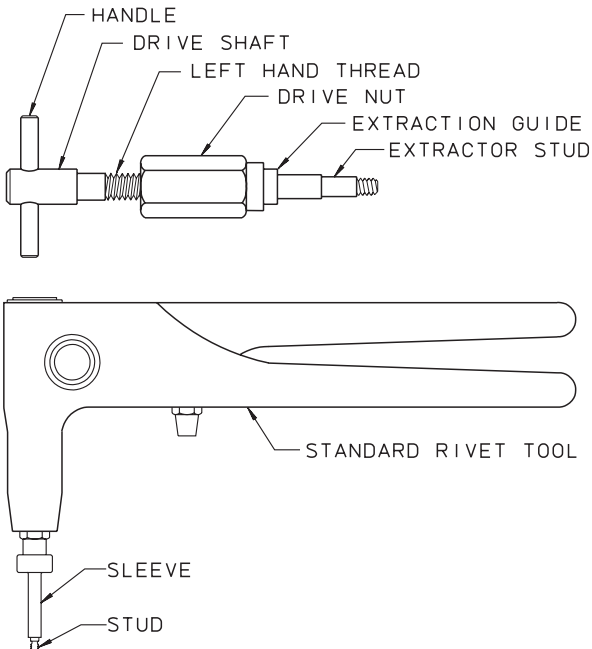

**PIN EXTRACTION METHOD • T-HANDLE**

1. Run the drive nut up the drive shaft until the extractor stud threads are clear of the extractor guide sleeve.
2. Engage the extractor stud threads with the mating pin threads.
3. Hold the T-handle to prevent the stud from turning, and run the drive nut down the drive shaft thread until the face of the extractor guide sleeve bears against the exposed face of the insert body.
4. While grasping the T-handle with the left hand, use an open-end wrench to turn the drive nut in a counterclockwise direction.
5. Diminished drive nut wrenching force indicates pin is free.

**PIN EXTRACTION METHOD • RIVET TOOL**

1. Thread the stud into the pin to be removed.
2. Slide the sleeve down over the stud until it is seated against the end of the body.
3. Engage the pin end of the stud with a rivet tool and squeeze the handle until the pin is free.

BODY DIAMETER	INST. / EXTR. TOOL KIT PART #	T-HANDLE	RIVET TOOL
		PIN JACKING TOOL PART #	PIN JACKING TOOL PART #
0.187 / 0.197	CUTA1870104C CUTA1870110C CUTA1870128C CUTA1870160C CUTA1870306C	CUTA1870204B	CUTA1870404B
0.250 / 0.260	CUTA2500106C CUTA2000113C CUTA2500306C	CUTA2500206B CUTA2000213B CUTA2500806B	CUTA2500313B CUTA2500706B CUTA2500606B
0.281 / 0.291	CUTA2810114C	CUTA2810214B	CUTA2810314B
0.375 / 0.385	CUTA3750106C	CUTA3750206B	—
0.500 / 0.510	CUTA5000106C CUTA5000116C	CUTA5000216B CUTA5000216B	— —

Rivet Gun Part Number ..... CUTA1870504B

## INSTALLATION & EXTRACTION OF 3-PORT INSERTS

3-port inserts require an additional seal beyond the normal locking end. This is accomplished with a "nose seal" or "compression seal" that requires a different installation and extraction procedure than Lee 2-Port inserts.

The nose seal and compression seals create a robust seal using the same expansion principle as a locking end, except a tapered section at the end of the insert body acts as the tapered pin. The seal rests on a 45° shoulder and is expanded as the preload force is applied, and the insert is pressed down into the installation hole.

Preload is a critical step of the installation procedure. After the preload is applied, the pin is installed, and the position of the insert and the appropriately expanded seal are locked into place for the remainder of its service life.

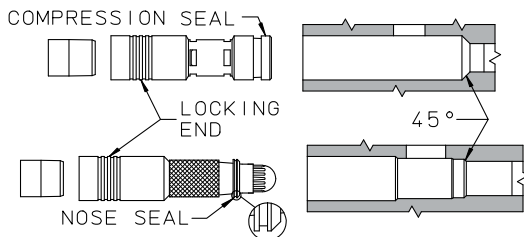

## INSTALLATION METHOD

1. Thread the insert body onto the body installation tool.
2. The insert body and seal must be installed using a controlled force called the preload. This ensures correct expansion of the seal and proper seating of the part. The appropriate force for each valve can be found on the relevant Lee drawing.
3. Remove the body installation tool.
4. Thread the pin onto the pin installation tool.
5. Drive the pin into the body until the pin is flush with the body to within  $\pm 0.005$  inch.

Refer to Lee Process Specification PS J2374 "Installation of Lee 3-Port Inserts" for further instruction on the installation procedure.

**EXTRACTION METHOD**

1. Remove the pin by using one of the previously described pin removal methods.
2. Slide the striker onto the body extraction tool and thread it into the body.
3. Strike the head of the body extraction tool with the striker until the body is removed.
4. Use the nose seal removal tool to remove the nose seal. Discard used pin and nose seal.

For a more detailed installation and extraction procedure see Process Specification 187.

**REINSTALLATION**

With reasonable care, 3-Port inserts are reusable without further machining until the fifth or sixth insertion/removal cycle. A new pin and a new nose seal must be used for every new installation. When an installation hole is no longer serviceable, re-ream to 0.010 inch over the original size (same depth and same tolerances) and use an oversize insert.

BODY DIA. STANDARD/ OVERSIZE	INST./EXTR. TOOL KIT PART NUMBER	PIN INST./EXTR. THREAD SIZE	BODY INST./EXTR. THREAD SIZE
0.187 / 0.197	CUTA1870137C	0.112 - 40	0.138 - 40
0.281 / 0.291	CUTA2810137C	0.138 - 40	0.250 - 48
0.500 / 0.510	CUTA5000137C	0.250 - 32	0.4375 - 28

## INSTALLATION FOR NORMAL TEMPERATURE OPERATION

For temperatures from -65° to 300°F install the Visco Jets as shown below. For other temperatures see “Installation for High and Low Temperature Operation” on the following [pages](#).

Note: The “A” Washer is a separate piece to facilitate the installation of the “O” rings.

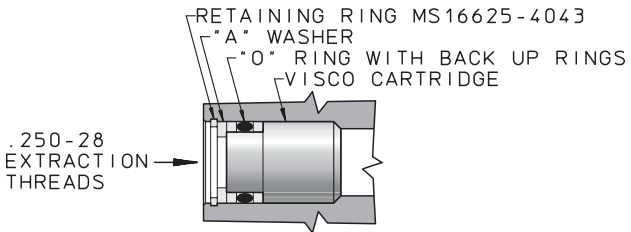

### VDCA43 SERIES

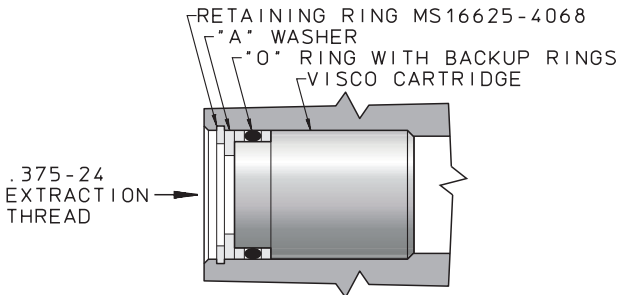

### VDCA68 SERIES

**INSTALLATION FOR HIGH AND LOW TEMPERATURE OPERATION**

The "B" washer is used whenever a metal "O" ring is used because of the axial forces required to compress the ring. The "B" washer may also be used with elastomer rings if the customer prefers this method in lieu of a snap ring.

For installation prepare the hole as shown on the following two pages. Place the Visco Jet assembly with the "O" ring into the reamed hole and thread in the "B" washer. Lock in place as shown on [page N36](#).

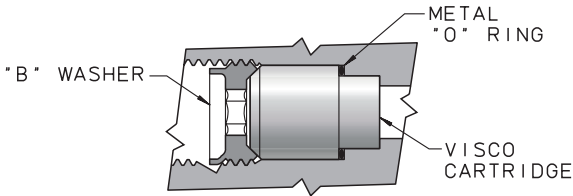
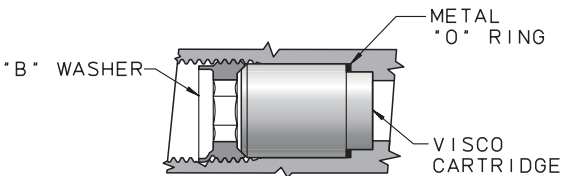
**43 SERIES****68 SERIES**

## HIGH & LOW TEMPERATURE OPERATION RECOMMENDED HOLE DIMENSIONS

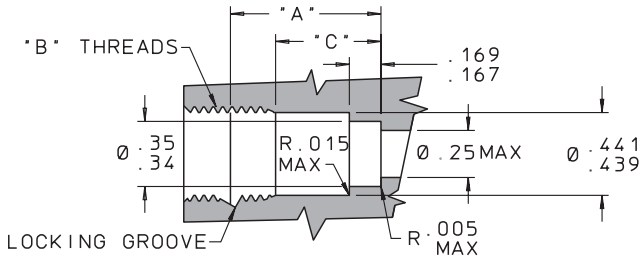

### 43 SERIES

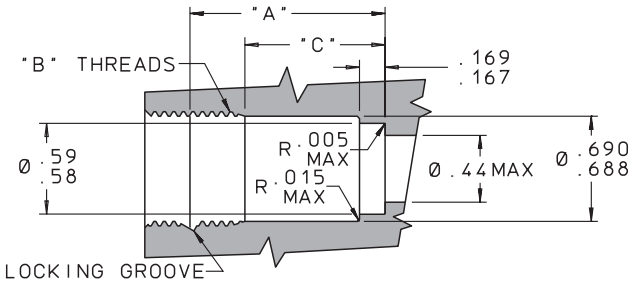

### 68 SERIES

See table on [page N36](#) for "A", "B" and "C" dimensions.

VISCO SERIES	LOHM RATE	"A" * DIM.	O-RING	"B" THREADS	
				DIAMETER	MAX. DIST. "C"
43 Series	32 600	0.66	Metal (Stn. Stl.) Plated (Silver) per AMS7325	.500-20 UNF Thread 0.453 Dia. Tap Drill)	0.43
	46 000	0.66			0.43
	56 500	0.80			0.56
	65 000	0.80			0.56
	73 000	0.80			0.56
68 Series	8 800	1.06	Metal (Stn. Stl.) Plated (Silver) per AMS7325	0.750-16 UNF Thread (0.688/0.690 Dia. Tap Drill)	0.70
	12 400	1.06			0.70
	15 200	1.28			0.92
	7 600	1.28			0.92
	19 600	1.39			1.03

\* Total mounting length of cartridge to lip edge of "B" washer

1. Cut the locking groove with a 0.12 inch diameter end mill to 2 x thread height.
2. Start the cut 0.06 inch before the lip edge of the "B" washer (see "A" dimension) at an approximate 30° angle. (All "B" washers are supplied with the necessary lip for locking.)
3. Using a punch or similar tool, expand the section of the "B" washer above the groove, into the locking groove.
4. For removal, the lip may be pried up.

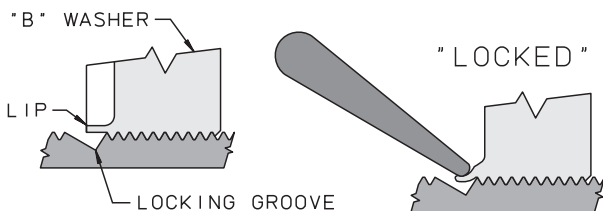

## INSTALLATION PROCEDURE

1. Lubricate the Microjet O-Ring with fluorosilicone compatible lubricant.
2. Insert the Microjet nose first into the sleeve, part number CUTA2711204A, from the flange end. Be sure the Microjet is pressed into the sleeve squarely to prevent the O-Ring from being pinched.
3. Insert the sleeve and Microjet into the installation hole until it bottoms. The sleeve will align the Microjet with the installation bore.
4. Using the installation end of tool part number CUTA2711104C, gently press the Microjet through the sleeve and into its installation area until it bottoms out.
5. Remove the tool and sleeve.

## EXTRACTION PROCEDURE

1. Insert the extraction tool part number CUTA2711104C, into the I.D. of the Microjet.
2. Engage the raised lip of the tool into the undercut in the I.D. of the Microjet body.
3. Gently pull the Microjet with the tool from its installation hole.



**SLEEVE**

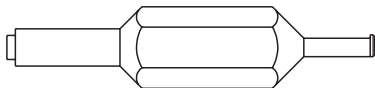

**INSTALLATION/  
EXTRACTION  
TOOL**

## INSTALLATION & EXTRACTION OF L-4 SAFETY SCREENS

The L-4 locking end is a retention system that allows installation in a bore without the need for a support shoulder. The basic principle of L-4 utilizes a tapered pin to expand three wings in the bore. The wings have lands that positively lock the device in place. Once tightened the self-locking expander pin will not loosen.

The L-4 installation/extraction tool set consists of an extractor rod and a socket wrench.

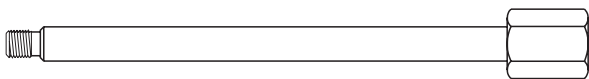

**EXTRACTOR ROD**



**END VIEW**

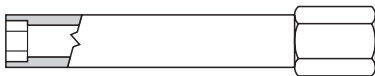

**SOCKET WRENCH**

## INSTALLATION METHOD

1. Insert the extractor rod through the socket wrench.
2. Thread the extractor rod onto the expander pin of the safety screen.
3. Push the safety screen into the bore until the proper depth is reached.
4. Turn the socket wrench in a clockwise direction until finger tight.

5. Remove the extractor rod by rotating in a counter clockwise direction while holding the socket wrench.
6. Use a torque wrench with the socket wrench.
7. Torque to the value in the table below.
8. Remove the socket wrench.

SCREEN DIAMETER	TOOL SET PART NUMBER	SOCKET WRENCH EXTERNAL HEX	TORQUE (in - lbs)
.187	CUTA1870528C	.250	3.5 – 4.5
.281	CUTA2810528C	.312	10 – 14

## EXTRACTION METHOD

1. Insert the extractor rod through the socket wrench.
2. Thread the extractor rod onto the expander pin of the safety screen.
3. Turn the socket wrench in a counter clockwise direction using a wrench (see table for size).
4. When the assembly becomes loose, extract the screen from the bore.
5. Remove the extractor rod by rotating in a counter clockwise direction while holding the socket wrench.

## REINSTALLATION

After cleaning and inspection, the L-4 safety screen may be reused.

**SPRING RETAINED SAFETY SCREEN  
INSTALLATION & EXTRACTION**

1. Insert the screen assembly into the machined mounting hole with the screen base washer firmly seated against the shoulder.
2. Slip the spring tang into the slots of the insertion tool, CUTA1700128C, and engage by turning it counterclockwise.
3. Press the spring against the chamfer of the mounting hole. Maintain pressure while rotating the tool in a counterclockwise direction. Continue rotation until the spring seats solidly on the safety screen base washer. Disengage the installation tool and remove it.
4. The safety screen assembly is now retained by the compressed torsion spring.
5. For inspection or removal, engage the tool with the spring tang and continue to rotate counterclockwise while extracting the spring.

**TWIS SAFETY SCREEN INSTALLATION  
AND EXTRACTION METHOD**

1. Screw the screen assembly into the end of the insertion tool CUTA1870228C.
2. Twist clockwise (5 in.- oz. torque) with the insertion tool while pushing the assembly into the reamed hole (0.25 lbs. axial force required).
3. When the screen is seated against the shoulder, unscrew the insertion tool.
4. To remove the screen assembly for cleaning or inspection, screw the insertion tool all the way onto the screen assembly, then continue turning clockwise while pulling the screen assembly from the hole.

## KIPSTER INSTALLATION/EXTRACTION AND PRESSURE MEASUREMENT

1. Screw the Kipster onto the end of installation tool RTTA1870100.
2. Twist clockwise (5 in. - oz. torque) with the installation tool while pushing the assembly into the reamed hole (0.25 lbs. axial force required).
3. When the part is at the desired depth, unscrew the installation tool.
4. When installed, the assembly is capable of with standing an axial force of 8 lbs.
5. To remove the Kipster for peak pressure measurement, screw the installation tool onto the Kipster. Continue to turn in a clockwise direction and pull until the Kipster is extracted from the hole.
6. The Kipster, once retracted, can be removed from the tool for measurement.
7. Using the dial gauge and zeroing block from tool set RTTA1870150, zero the dial gauge, then measure the depth of the dimple.
8. Referring to the deflection profile on [page M13](#), read the pressure using the appropriate temperature curve.

# Engineering

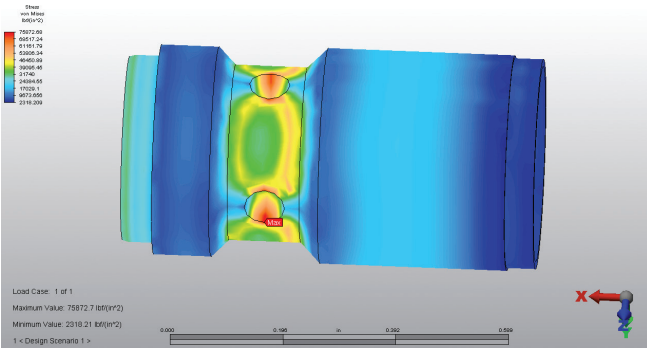
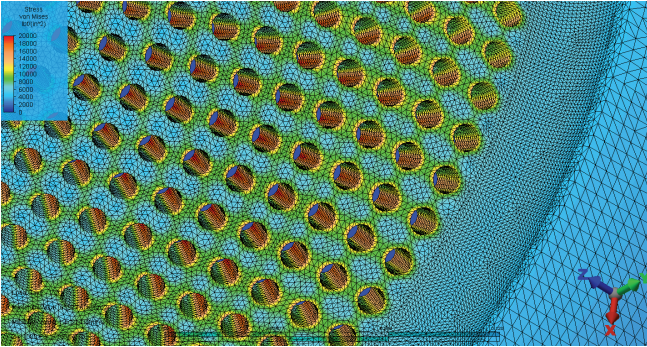

- Liquid Flow Equations**
- Gas Flow Equations**
- Design Information**
- Reference Information**
- Conversion Factors**
- Graphic Symbols**
- Definitions**



## TABLE OF CONTENTS

### Lohm Laws

Definition .....	3 – 4
Liquid Flow .....	5 – 17
Hydraulic Power .....	18 – 19
Temperature Rise in Hydraulic Fluids .....	20 – 21
Momentum Forces .....	22
Water Hammer .....	23
Bulk Modulus .....	24 – 28
Cavitation .....	29
Gas Flow .....	30 – 44
Momentum Forces - Gas Flow .....	45
Transient Gas Flow .....	46 – 47
Temperature Change in Gas Flow .....	48 – 49
Pneumatic Power .....	50 – 51
Gas Properties .....	52

### ROB Number

Definition .....	53 – 55
Table of Single Orifice ROB Numbers .....	56 – 57

### Contamination Control .....

58 – 62

### Pressure Ratings .....

63 – 69

### Reference Information

Primary Standards .....	70
Conversion Factors .....	71 – 79
Graphic Symbols .....	80 – 83
Metric Dimensions of Lee Inserts .....	84
Definitions of Viscosity .....	85

### General Information

Marking of Standard Lee Inserts .....	86
Policy for Specially Fabricated Parts, Proprietary Rights .....	87
Trademarks of The Lee Company .....	88 – 89
Patents, Trademarks, Copyrights, Warranty .....	90
Directory of Technical Publications .....	91



**DEFINITION**

Every engineer will be interested in our simple system of defining the fluid resistance of Lee hydraulic components.

Just as the OHM is used in the electrical industry, we find that we can use a liquid OHM or “Lohm” to good advantage on all hydraulic computations.

When using the Lohm system, you can forget about coefficients of discharge and dimensional tolerances on drilled holes. These factors are automatically compensated for in the Lohm calculations, and confirmed by testing each component to establish flow tolerances. The resistance to flow of any fluid component can be expressed in Lohms.

The Lohm has been selected so that a 1 Lohm restriction will permit a flow of 100 gallons per minute of water with a pressure drop of 25 psi at a temperature of 80° F.

The graph on the following page relates Lohms to hole diameter.



## LOHM RATE VERSUS ORIFICE DIAMETER

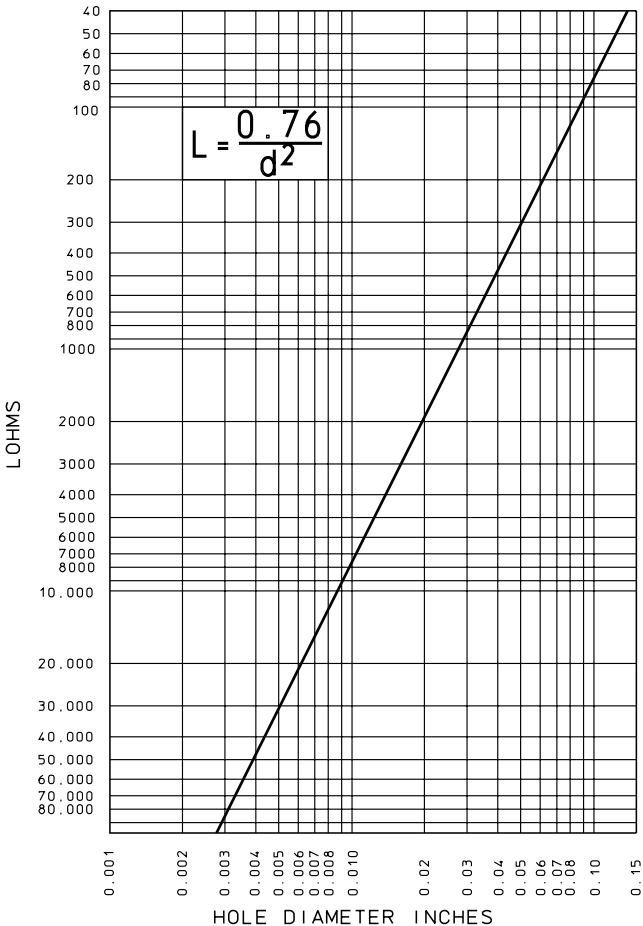

**WATER FLOW – LOHM RATE FORMULA**

The Lohm has been selected so that a 1 Lohm restriction will permit a flow of 100 gallons per minute of water with a pressure drop of 25 psi at a temperature of 80°F.

$$L = 20 \frac{\sqrt{H}}{I} \qquad I = 20 \frac{\sqrt{H}}{L}$$

$$H = \frac{I^2 \times L^2}{400}$$

Where:

- I = Flow rate (gallons per minute).
- H = Differential pressure (psi).
- L = Lohm rate, a measure of resistance to liquid flow. It includes all density, viscosity, Reynolds number, coefficient of discharge & area units (Lohms).

When testing on water at 25 psi  $\Delta P$ ,  $\sqrt{H} = 5$   
and the above formulas simplify as follows:

$$L = \frac{100}{I} \qquad \text{and} \qquad I = \frac{100}{L}$$

Some useful relationships:

1. 1000 Lohms will permit a flow of 50 lb/hr water at 25 psi  $\Delta P$ .
2. Flow Coefficient,  $C_v = \frac{20}{L}$
3.  $L = \frac{0.76}{d^2}$                        $L = \frac{0.527}{C_d A}$



**WATER FLOW - EXAMPLES**

**Problem 1.** What restriction will permit a flow of 1 gallon of water per hour at 50 psi  $\Delta P$ ?

$$I = 1/60 = 0.0167 \text{ GPM}$$

$$L = \frac{20 \sqrt{H}}{I} = \frac{20 \sqrt{50}}{0.0167} = 8500 \text{ Lohms}$$

**Problem 2.** A jet with an approximate hole diameter of .012" flows 18 lb/hr of water at 100 psi  $\Delta P$ . What is the restriction?

$$I = \frac{18}{60 \times 8.345} = 0.036 \text{ GPM}$$

$$L = \frac{20 \sqrt{H}}{I} = \frac{20 \sqrt{100}}{0.036} = \frac{200}{0.036} = 5500 \text{ Lohms}$$

**Problem 3.** What  $\Delta P$  will be required to flow 20 GPH of water through a 2000 Lohm Jet?

$$I = \frac{20}{60} = 0.333 \text{ GPM}$$

$$H = \frac{I^2 \times L^2}{400} = \frac{0.333^2 \times 2000^2}{400} = \frac{0.111 \times 4,000,000}{400} = 1110 \text{ psi } \Delta P$$

**Problem 4.** What water flow will result from a restriction of 500 Lohms and a  $\Delta P$  of 500 psi?

$$I = \frac{20 \sqrt{H}}{L} = \frac{20 \sqrt{500}}{500} = 0.894 \text{ GPM}$$

NOTE:

For special flow requirements, The Lee Company can determine the required Lohm rating.



## LIQUID FLOW - COMBINATIONS OF RESTRICTIONS

**PARALLEL FLOW**, the total Lohm rating is:

$$\frac{1}{L_T} = \frac{1}{L_1} + \frac{1}{L_2} + \frac{1}{L_3} + \dots + \frac{1}{L_N}$$

Please note that this relationship is identical to the electrical equation.

EXAMPLE: Parallel flow

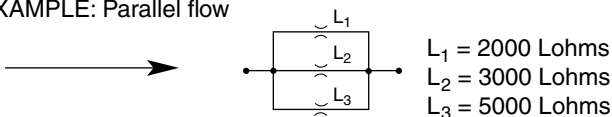

$$\frac{1}{L_T} = \frac{1}{2000} + \frac{1}{3000} + \frac{1}{5000} = 0.00103 \text{ and therefore } L_T = 970 \text{ Lohms}$$

**SERIES FLOW**, the total Lohm rating is:

$$L_T = \sqrt{L_1^2 + L_2^2 + L_3^2 + \dots + L_N^2}$$

Please note that this relationship is not the same as in electrical problems. The difference is due to the non-linearity of

$$H = \frac{I^2 L^2}{400}$$

EXAMPLE: Series flow:



$$L_T = \sqrt{2000^2 + 3000^2 + 5000^2} = 6160 \text{ Lohms}$$

When  $L_1 = L_2 = L_3$ , then  $L_T = L \sqrt{N}$

$N$  = Number of equal resistors in series

For passageway size:  $D_T = D / N^{1/4}$

$D_T$  = Diameter of a single equivalent orifice, with a Lohm rate =  $L_T$

$D$  = Diameter of the actual orifices, each with a Lohm rate =  $L_1$



**LIQUID FLOW - SERIES FLOW**

One of the reasons for using two restrictors in series is to allow fine tuning of a total resistance value. If  $L_1$  is known and is more than 90% of  $L_T$ , then  $L_2$  may vary by  $\pm 5\%$  without altering the value of  $L_T$  by more than  $\pm 1\%$ , even though the value of  $L_2$  may be as high as 40% of  $L_T$ . This effect becomes even more pronounced as  $L_1$  approaches  $L_T$ .

To determine the intermediate pressure between two resistances in series, the following formulas may be used.

$$\Delta P_1 = \frac{\Delta P_T}{1 + (L_2/L_1)^2}$$

$$\Delta P_2 = \frac{\Delta P_T}{1 + (L_1/L_2)^2}$$

$$\left(\frac{L_1}{L_2}\right)^2 = \frac{\Delta P_1}{\Delta P_2}$$

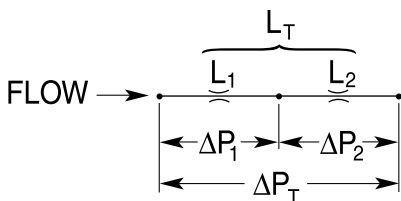

## LIQUID FLOW - LOHM RATE FORMULA

The following formulas are presented to extend the use of the Lohm laws to many different liquids, operating over a wide range of pressure conditions.

These formulas introduce compensation factors for liquid density and viscosity. They are applicable to any liquid of known properties, with minimum restrictions on pressure levels or temperature.

The units constant (K) eliminates the need to convert pressure and flow parameters to special units.

Volumetric Flow Units

$$L = \frac{KV}{I} \sqrt{\frac{H}{S}}$$

Gravimetric Flow Units

$$L = \frac{KV}{w} \sqrt{HS}$$

Where:

- L = Lohm rate (Lohms)
- H = Differential pressure
- I = Liquid flow rate: Volumetric
- S = Specific gravity\* (see page O16)
- V = Viscosity compensation factor\*\* (see page O13)
- w = Liquid flow rate: Gravimetric
- K = Units Constant – Liquid (see page O10)

\* S = 1.0 for water at 80°F.

\*\* V = 1.0 for water at 80°F.



## LIQUID FLOW - UNITS CONSTANT K

Volumetric Flow Units

$$L = \frac{KV}{I} \sqrt{\frac{H}{S}}$$

VOLUMETRIC FLOW UNITS			
Flow Units	Pressure Units		
	psi	bar	kPa
GPM	20	76.2	7.62
L/min	75.7	288	28.8
ml/min	75 700	288 000	28 800
in <sup>3</sup> /min	4 620	17 600	1 760

Gravimetric Flow Units

$$L = \frac{KV}{w} \sqrt{HS}$$

GRAVIMETRIC FLOW UNITS			
Flow Units	Pressure Units		
	psi	bar	kPa
PPH	10 000	38 100	3 810
gm/min	75 700	288 000	28 800

**LIQUID FLOW CALCULATIONS - EXAMPLES**

**Problem 1.** A single orifice restrictor is required to flow 0.15 GPM of MIL-H-83282 hydraulic fluid at 80°F and 100 psi  $\Delta P$ . What restriction is required?

*Solution:*

1. Read specific gravity;  $S = 0.84$  from chart on [page O17](#).
2. Read viscosity;  $v = 21$ cs. From chart on [page O14](#).
3. Use viscosity and  $\Delta P$  to determine viscosity compensation factor  $V = 0.95$  from graph on [page O13](#).
4. Select units constant,  $K = 20$  from table on [page O10](#).

$$L = \frac{KV}{I} \sqrt{\frac{H}{S}} = \frac{20 (0.95)}{0.15} \sqrt{\frac{100}{0.84}} = 1380 \text{ Lohms}$$

**Problem 2.** What pressure drop will result from a flow of 5 PPH of SAE #10 lubricating oil at 20°F, flowing through a 1000 Lohm single orifice restrictor?

*Solution:*

1. Read specific gravity and viscosity.  
 $S = 0.90$ ,  $v = 600$ cs.
2. Use knowledge of system to assume solution.  
 $H = 50$  psid.
3. Use assumed  $\Delta P$  to determine  $V = 0.18$
4. Select units constant,  $K = 10,000$  from table on [page O10](#)
5. Compute trial  $\Delta P$ .

$$H = \frac{w^2 L^2}{S K^2 V^2} = \frac{5^2 (1000)^2}{0.90 (10,000)^2 0.18^2} = 8.6 \text{ psid}$$

6. Make trials as required to find correct solution.  
 $H = 26$  psid.



**LIQUID FLOW – EXAMPLES**

**Problem 3.** A Flow Control is required to flow 775 lb/hr of JP4 @ 80°F with a maximum pressure drop of 5 psid. What is the maximum Lohm rate allowed for the Flow Control?

*Solution:*

1. Find specific gravity;  $S = 0.77$  from curve on [page O16](#).
2. Find viscosity;  $\nu = 1\text{cs}$  from curve on [page O14](#).
3. Use  $\nu$  and  $\Delta P$  to determine viscosity compensation factor,  $V = 1.0$  from curve on [page O13](#).
4. Select units constant,  $K = 10,000$  from table on [page O10](#).

$$L = \frac{KV}{w} \sqrt{HS} = \frac{10000(1)}{775} \sqrt{5(0.77)} = 25 \text{ Lohms Maximum}$$



**VISCOSITY COMPENSATION FACTOR  
FOR SINGLE ORIFICE**

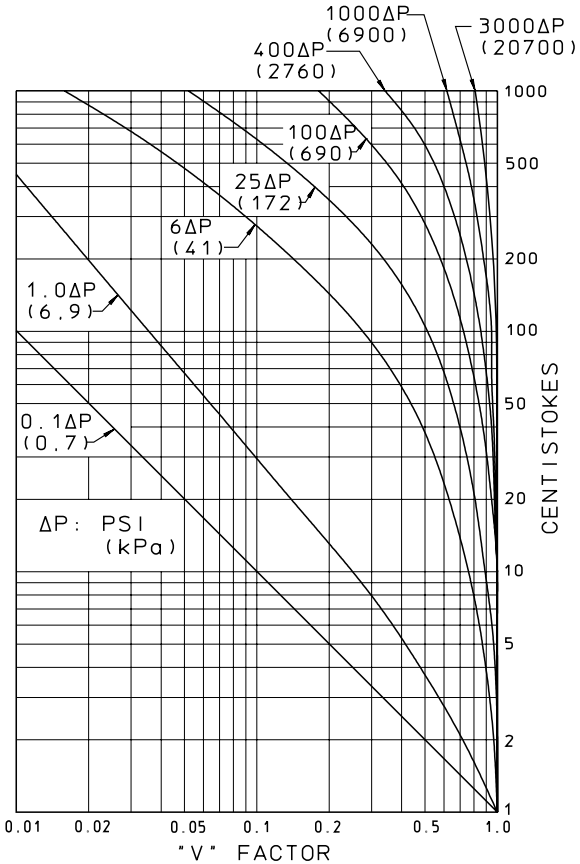



**VISCOSITIES OF  
TYPICAL FLUIDS vs TEMPERATURE**

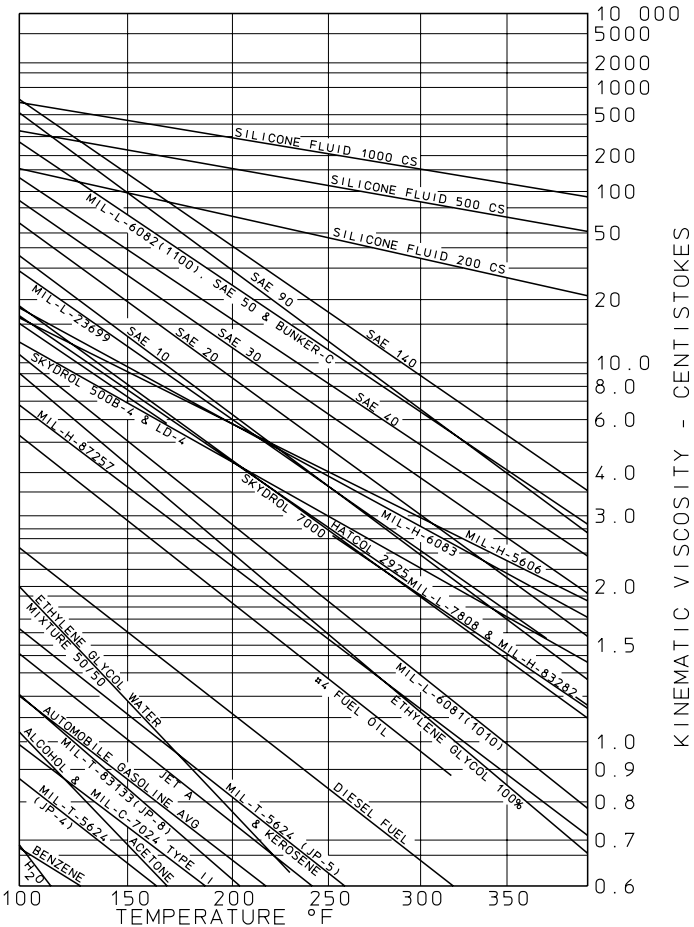

KINEMATIC VISCOSITY - CENTISTOKES



## SPECIFIC GRAVITY OF TYPICAL FLUIDS vs TEMPERATURE

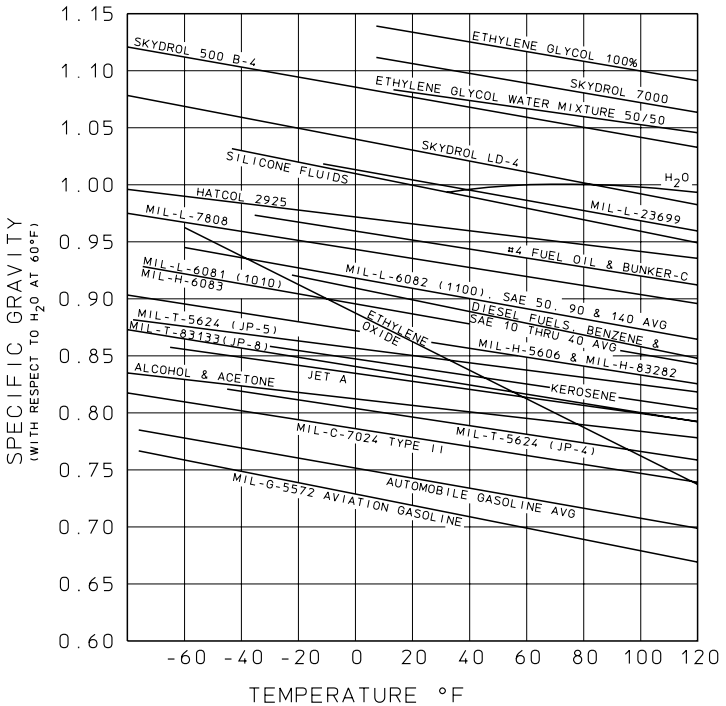

**SPECIFIC GRAVITY OF  
TYPICAL FLUIDS vs TEMPERATURE**

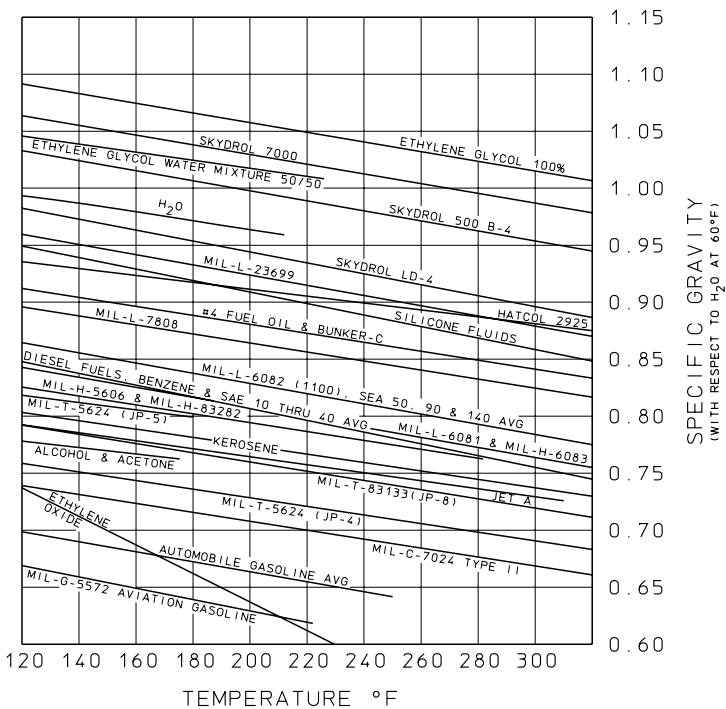

**HYDRAULIC POWER**

Whenever there is flow through an orifice, there is a power consumption (or loss) which is a function of the pressure drop and the flow rate. The following data is useful in calculating the hydraulic power requirements of a system.

$$HP = \frac{H \times I}{1714}$$

Where:

H = Pressure drop (psi)

I = Flow rate (GPM)

HP = Hydraulic power  
(horsepower)

The hydraulic power can also be expressed in another convenient form.

**For Water Applications:**

$$HP = \frac{0.0117 H^{3/2}}{L} \quad \text{or} \quad \frac{0.0117 H \sqrt{H}}{L}$$

The nomogram on the opposite [page](#) shows this relationship.

**For Liquid Applications:**

$$HP = \frac{0.0117 HV \sqrt{\frac{H}{SG}}}{L}$$

Where:

V = Viscosity compensation factor

SG = Specific gravity

L = Lohm rate (Lohms)

**EXAMPLE:**

A Lee Chek Valve such as CKRA1876005 with 400 Lohms will flow 0.35 GPM of water at 50 psid. At those conditions, what horsepower is lost?

$$HP = \frac{H \times I}{1714} = \frac{50 \times 0.35}{1714}$$

$$HP = 0.010 \text{ Horsepower}$$



**NOMOGRAM FOR HYDRAULIC POWER - WATER APPLICATIONS**

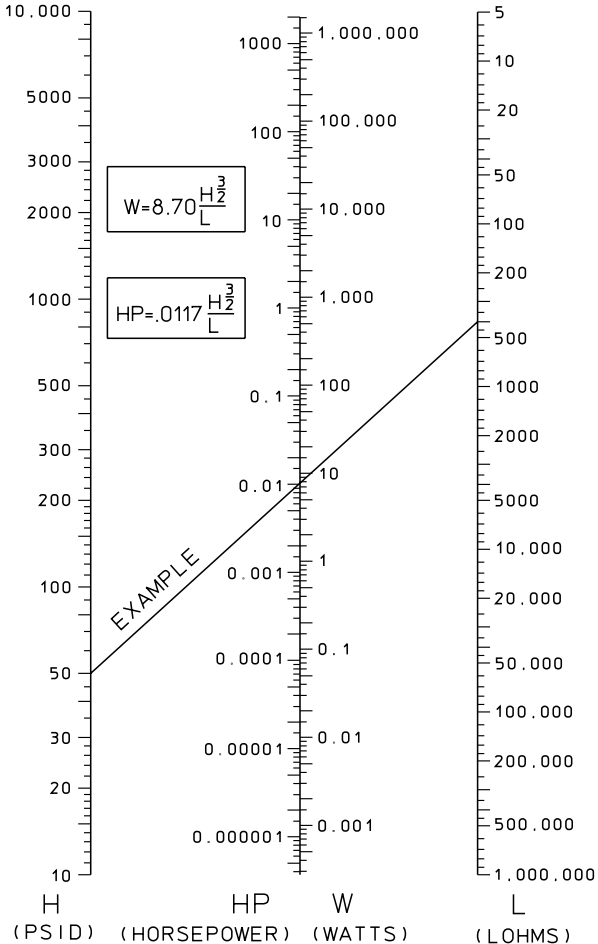

**TEMPERATURE RISE IN HYDRAULIC FLUIDS**

Hydraulic fluid heats when flowing through a restriction as the pressure energy upstream of the restriction is converted into thermal energy.

$$\Delta T = \frac{0.003 (\Delta P)}{(S) (c)}$$

FLUID	C
Water	1.00
JP-4	0.50
JP-8/JET A	0.48
MIL-H-5606	0.47
MIL-H-83282	0.50
Skydrol 500 B-4	0.42
Skydrol LD-4	0.44
Silicone 100cs	0.35
Gasoline	0.50

Where:

$\Delta T$  = Temp. rise ( $^{\circ}\text{F}$ )

$\Delta P$  = Pressure drop (psi)

S = Specific gravity

c = Specific heat at  $100^{\circ}\text{F}$   
(BTU/LB<sub>m</sub>  $^{\circ}\text{F}$ )

**EXAMPLE:**

If a Lee Jet is flowing MIL-H-83282 at  $120^{\circ}\text{F}$  and 2500 psid, the temperature rise across the Lee Jet is computed as follows:

For MIL-H-83282 at  $120^{\circ}\text{F}$ , S = 0.82, c = 0.50

$$\Delta T = \frac{(0.003) (2500)}{(0.82) (0.50)} = 18.3^{\circ}\text{F}$$



TEMPERATURE RISE IN HYDRAULIC FLUIDS

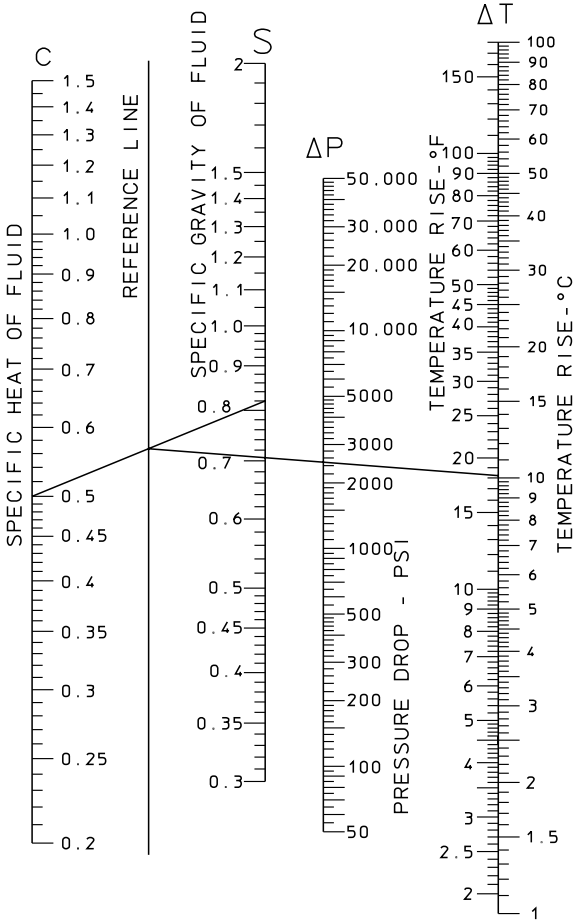

1. Connect **c** to **S**
2. From point on reference line, connect  $\Delta P$  and extend to  $\Delta T$ .



**MOMENTUM FORCES - LIQUID FLOW**

The momentum Lohm Laws give the designer simple formulas to determine the forces caused by changes in velocity (either speed or direction) of a liquid.

$$F = \frac{SI^2L}{431} \quad F = \frac{0.93 HV^2}{L} \quad F = \frac{IV \sqrt{HS}}{21.5}$$

F = Force (lb<sub>f</sub>)

H = Pressure drop (psi)

I = Flow rate (GPM)

S = Specific gravity

V = Viscosity compensation factor

These forces are produced by local pressure gradients, and should be added to the forces produced by the static pressure. It is often useful to sketch these pressure gradients to determine the direction of the momentum forces.

**EXAMPLE:** Where a liquid changes direction.

$$F_{\text{momentum}} = \frac{0.93 HV^2}{L} = \frac{0.93 \times 990 \times 1^2}{600} = 1.53 \text{ lb}_f$$

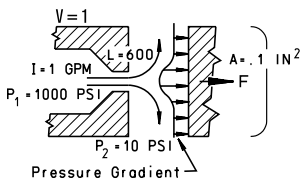

The momentum force of 1.53 lb<sub>f</sub> in this example must be added to the force produced by static pressure on the plate (of .1 in.<sup>2</sup> x 10 psi = 1 lb<sub>f</sub>) to give the total force on the plate, 2.53 lb<sub>f</sub>.

**EXAMPLE:** Where a liquid changes speed.

$$F_{\text{momentum}} = \frac{SI^2L}{431} = \frac{1 \times 2^2 \times 100}{431} = 0.9 \text{ lb}_f$$

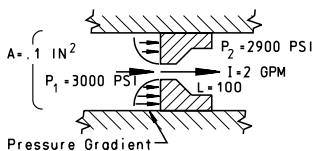

The momentum force of 0.9 lb<sub>f</sub> in this example must be subtracted from the force produced by static pressure on the plate (of 0.1 x [3000-2900] = 10 lb<sub>f</sub>) to give the total force on the piston.

**WATER HAMMER**

A brief pressure spike, commonly called water hammer, occurs when a high velocity fluid is suddenly stopped. It is often brought on by the fast closing of a valve somewhere in the system. The hydraulic system designer can approximate the magnitude of the pressure spike with the following formula that assumes a “hard” system with non-compliant fluid passages, and will, therefore, yield a worst case value for the peak pressure.

$$\Delta P = \frac{I}{16.6 D^2} \sqrt{S \times B}$$

$\Delta P$  = Pressure rise caused by water hammer effects (psi)

I = Flow rate (GPM)

S = Specific gravity, see [page O16](#)

B = Bulk modulus (psi)

D = Inside diameter of fluid passageway upstream of the Lee component (in.)

**EXAMPLE:** A Lee component (such as JEHA1875500L) is flowing 1 GPM of MIL-H-83282 at 80°F with 4000 psi upstream and 3500 psi downstream. The component is being fed through a 0.15 in. dia. passage upstream. If a valve is suddenly shut downstream of the component, the pressure spike will be:

$$\Delta P = \frac{1}{16.6 (0.15)^2} \sqrt{0.84 (300,000)} = 1,340 \text{ psi}$$

The maximum upstream pressure would then be:

(4000 psi steady state) + (1,340 psi spike) = 5,340 psi total



**BULK MODULUS**

Bulk Modulus is a measure of the resistance of a fluid to compression. It is defined as the ratio of pressure stress to volumetric strain. Assuming there is no entrained air in the system, bulk modulus can be expressed using the following formula:

$$B = - \frac{\Delta P}{\Delta V} \times V$$

Where:

- B = Bulk modulus (psi)
- $\Delta P$  = Change in pressure (psi)
- $\Delta V$  = Change in volume
- V = Initial volume

When the value of B is known (see reference table on next page), it is easy to calculate the effect of any pressure change on volume, or of any volume change on pressure.

$$\Delta V = - \frac{V}{B} \times \Delta P \quad \text{or} \quad \Delta P = - \frac{B}{V} \times \Delta V$$

**EXAMPLE:**

MIL-H-83282 oil has a bulk modulus of  $3.0 \times 10^5$  psi. Thus, a pressure increase of 3000 psi will reduce its volume by 1.0%.

**COEFFICIENT OF THERMAL EXPANSION**

Thermal Expansion is the tendency of a fluid to expand due to an increase in temperature. The coefficient of thermal expansion can be used to relate temperature change to volume change, as shown in the following formula.

$$\Delta V = V \times \gamma \times \Delta T$$

**EXAMPLE:**

MIL-H-83282 oil has a coefficient of cubical thermal expansion of  $0.00046/^\circ\text{F}$ . Thus a temperature rise of  $100^\circ\text{F}$  will increase a 2.0 gallon volume by 0.09 gallons.

The bulk modulus and the coefficient of cubical thermal expansion can be used together to compute the pressure rise in a closed system subjected to an increasing temperature.

$$\text{Pressure Rise: } \Delta P = B \times \gamma \times \Delta T$$



**COEFFICIENT OF THERMAL EXPANSION****EXAMPLE:**

MIL-H-83282 oil at 0 psi is heated from 70°F to 120°F in a closed, constant volume system containing 100 cu. in.

$$\Delta P = 3.0 \times 10^5 \times 0.00046 \times 50 = 6900 \text{ psi}$$

This is the same  $\Delta P$  which would be caused by adding 2.3 cubic inches of oil with no temperature change. It is also apparent that a constant system pressure could be maintained by bleeding off 2.3 cubic inches of oil while increasing the temperature by 50°F.

**REFERENCE TABLE**

FLUID	$B_{\text{ref.}}$	$\gamma$
Units	psi	$\Delta V/V/^\circ\text{F}$
Gasoline	150 000	0.00072
JP-4	200 000	0.00057
MIL-H-5606	260 000	0.00046
MIL-H-83282	300 000	0.00046
MIL-H-6083	260 000	0.00044
SKYDROL 500B-4	340 000	0.00047
Silicone 100cs	150 000	0.00054
Water	310 000	0.00021

Where:

$\Delta V$  = Change in volume

$V$  = Initial volume

$\Delta T$  = Temperature rise, °F

$B_{\text{ref.}}$  = Tangent adiabatic bulk modulus psi stated at 100°F, 2500 psi and no entrained air. A reference point.

$\gamma$  = Coefficient of cubical thermal expansion/°F at 100°F



## BULK MODULUS (ACTUAL)

The previous examples used a constant bulk modulus for simplicity. In actual use, the bulk modulus is affected by the working pressure, temperature and percent of entrained air. Use the next 3 graphs to find the effect of these variables, and you will get a close approximation of actual conditions. The actual bulk modulus,  $B$ , of a fluid is the value in the table on [page O25](#) as  $B_{ref.}$  modified for the effect of pressure, temperature and percent of entrained air.

The actual bulk modulus  $B = E_P \times E_T \times E_A \times B_{ref.}$

Where:

$E_P$  = Effect on pressure

$E_T$  = Effect on temperature

$E_A$  = Effect on entrained air

### EXAMPLE:

500 psi, 60°F, 2% entrained air, MIL-H-83282.

Actual  $B = 0.91 \times 1.10 \times 0.8 \times 300,000 = 240,000$  psi

### EXAMPLE:

2000 psi, 160°F, 2% entrained air, MIL-H-83282.

Actual  $B = 0.98 \times 0.86 \times 0.98 \times 300,000 = 248,000$  psi

With the corrected bulk moduli for the two end points of a thermal problem, an average bulk modulus can be selected for calculation purposes. We would use 244,000 psi for  $B$ .

See [Section F, page 7](#) for demonstrations on how these formulas can be applied to Lee thermal relief valves.



## BULK MODULUS

### WORKING PRESSURE

The effect of working pressure on bulk modulus for hydrocarbon fluids.

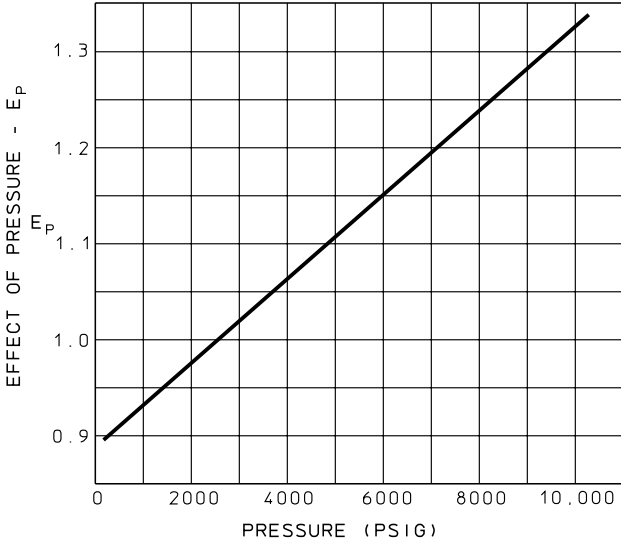

### TEMPERATURE

The effect of temperature on bulk modulus for hydrocarbon fluids.

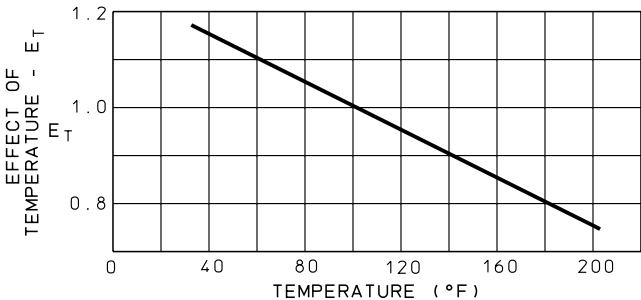

## BULK MODULUS ENTRAINED AIR

The effect of entrained air on bulk modulus in hydrocarbon and other fluids for different working pressures.

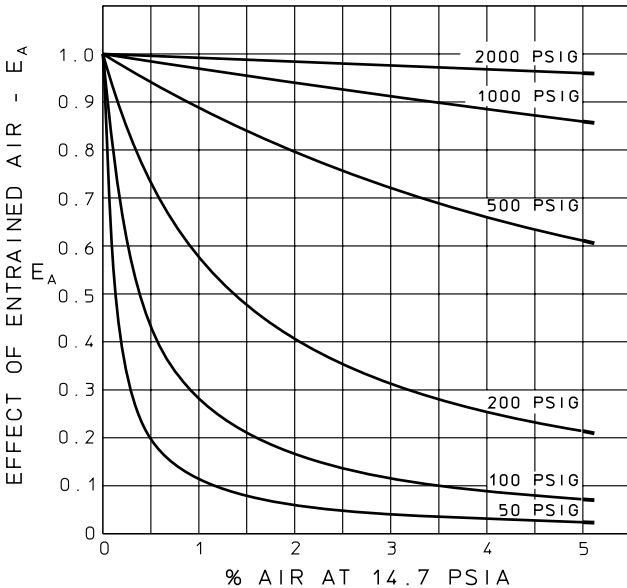

To simplify the calculations of thermal problems with entrained air, these curves show the *average* effect on a 230,000 psi bulk modulus for pressure points fairly close together. If a wide change in pressure is encountered in a problem, it would be more accurate to break the changes down into two or more steps, depending on the accuracy desired.

An accurate one step formula for this relationship follows:  
(Note that pressure is in units of psia.)

$$E_A = \frac{1}{\frac{0.147 B_{ref.}}{P_1 \times P_2} \times \% \text{ air} + 1}$$



## CAVITATION

Liquid flowing through any orifice will cavitate whenever its velocity causes the pressure in the throat of the orifice to drop below the vapor pressure of the flowing liquid. Even though there may be a high supply pressure and a high back pressure on the orifice, if the velocity is high enough there will be a subsequent lowering of the pressure in the throat of the orifice and the possibility of cavitation.

The effects of cavitation are choked flow and erosion - both of which are undesirable. To prevent cavitation, the throat pressure must be maintained, either by:

1. Applying sufficiently high back pressure, or
2. Reducing the velocity of the liquid as it flows through a restrictor.

The use of Lee Multi-Orifice Restrictors (Bender Jet, Axial Visco Jet, JEVA and Visco Jet) can significantly reduce the possibility of cavitation. Their unique design allows the total pressure drop to be divided across each individual orifice, reducing throat velocity and increasing back pressure relative to the pressure drop across each individual orifice.

It is recommended that Lee Multi-Orifice Restrictors be considered whenever high pressure drops and low back pressures are required.



**GAS FLOW – LOHM RATE FORMULA**

The Lohm Laws extend the definition of Lohms for gas flow at any pressure and temperature, and with any gas. The formulas work well for all gases because they are corrected for the specific gas and for the flow conditions caused by the compressibility of gases due to pressure.

A 100 Lohm restriction will permit a flow of 250 standard liters per minute of nitrogen at a temperature of 59°F, and an upstream pressure of 90 psia discharging to atmosphere.

$$L = \frac{K f_T P_1}{Q} \quad \text{(Sonic condition)} \\ \text{i.e. } P_1/P_2 \geq 1.9$$

$$L = \frac{2 K f_T \sqrt{\Delta P P_2}}{Q} \quad \text{(Subsonic condition)} \\ \text{i.e. } P_1/P_2 < 1.9$$

Where:

L = Lohm rate (Lohms)

K = Units Constant – Gas (see page O32 or O33)

$f_T$  = Temperature correction factor (see page O31)

$P_1$  = Upstream absolute pressure

$P_2$  = Downstream absolute pressure

Q = Gas flow rate

$\Delta P = P_1 - P_2$

Steps for using the gas lohm rate formula:

1. Compute the  $P_1/P_2$  pressure ratio.
2. Select the correct formula for the flow condition.
3. Look up the value of “K” for the gas.
4. Determine the temperature correction factor, “ $f_T$ ”.
5. Use the formula to solve for the unknown.

**TEMPERATURE CORRECTION FACTOR  $f_T$**

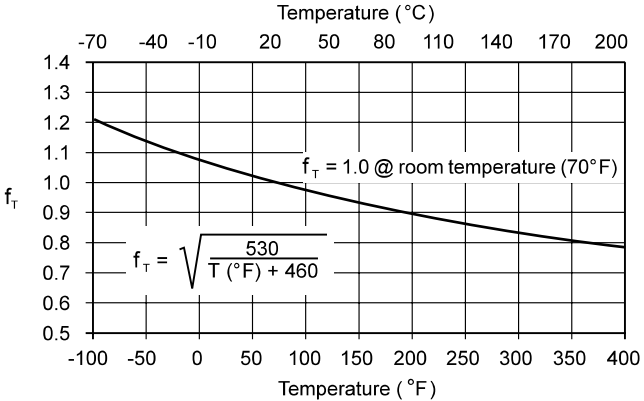

**GAS FLOW – EXAMPLE**

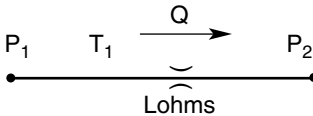

**EXAMPLE:** What restriction will permit a flow of 1.00 std L/min. of nitrogen at 90°F, with supply pressure at 5 psig, discharging to atmosphere?

$K = 276$  (see page O32)

$T_1 = 90^{\circ}\text{F}$ ,  $f_T = 0.98$  (see below)

$P_1 = 5.0 + 14.7 = 19.7$  psia,  $P_2 = 14.7$  psia

$P_1/P_2 = 19.7/14.7 = 1.34$  (subsonic)

$\Delta P = 5.0$  psid

$Q = 1.00$  std L/min.

$$L = \frac{2 (276) 0.98 \sqrt{5.0 (14.7)}}{1.00} = 4640 \text{ Lohms}$$



**GAS FLOW – UNITS CONSTANT “K”**

To eliminate the need to convert pressure and flow parameters into specific units such as “psia” and “std L/min.,” the table below lists values of the Units Constant “K,” which is used in the Gas Flow Lohm Formulas:

$$\text{Lohms} = \frac{K f_T P_1}{Q} \quad (\text{Sonic: } P_1 / P_2 \geq 1.9)$$

$$\text{Lohms} = \frac{2 K f_T \sqrt{\Delta P} P_2}{Q} \quad (\text{Subsonic: } P_1 / P_2 < 1.9)$$

VOLUMETRIC FLOW UNITS							
Abs. Pres	psia			bar		kPa	mm. Hg
Flow	SLPM	SCFM	in <sup>3</sup> /min	SLPM	SCFM	SLPM	mL/min
H <sub>2</sub>	1030	36.3	62 700	14 900	526	149	19 900
He	771	27.2	47 100	11 200	395	112	14 900
Neon	343	12.1	20 900	4 980	176	49.8	6 640
Nat. Gas	319	11.3	19 400	4 620	163	46.2	6 160
N <sub>2</sub>	276	9.73	16 800	4 000	141	40.0	5 330
CO	274	9.69	16 700	3 980	141	39.8	5 300
Air	271	9.56	16 500	3 930	139	39.3	5 230
Ethane	251	8.86	15 300	3 640	129	36.4	4 850
O <sub>2</sub>	257	9.08	15 700	3 730	132	37.3	4 970
Argon	245	8.65	14 900	3 550	125	35.5	4 730
CO <sub>2</sub>	213	7.52	13 000	3 090	109	30.9	4 110
N <sub>2</sub> O	214	7.56	13 100	3 100	110	31.0	4 140
SO <sub>2</sub>	176	6.21	10 700	2 550	90.1	25.5	3 400
Freon-12	123	4.34	7 510	1 780	63.0	17.8	2 380
Xe	135	4.77	8 235	1 956	69.1	19.6	2 605

**GAS FLOW – UNITS CONSTANT “K”****Example:**

If a lohm rate is being calculated for an Argon application using PPH and bar as the flow and pressure units, the units constant is 792.

GRAVIMETRIC FLOW UNITS							
Abs. Pres	psia			bar		kPa	mm. Hg
Flow	PPH	lb <sub>m</sub> /s	kg/min	PPH	kg/min	kg/min	gm/mi
H <sub>2</sub>	11.6	0.00322	0.0876	168	1.27	0.0127	1.69
He	17.3	0.00479	0.131	250	1.89	0.0189	2.52
Neon	38.7	0.0108	0.293	561	4.25	0.0425	5.66
Nat. Gas	34.8	0.00966	0.263	505	3.82	0.0382	5.09
N <sub>2</sub>	43.2	0.0120	0.326	626	4.73	0.0473	6.31
CO	43.0	0.0119	0.325	623	4.71	0.0471	6.28
Air	43.8	0.0122	0.331	636	4.81	0.0481	6.41
Ethane	42.2	0.0117	0.319	611	4.62	0.0462	6.16
O <sub>2</sub>	46.0	0.0128	0.348	667	5.04	0.0504	6.72
Argon	54.6	0.0152	0.413	792	5.99	0.0599	7.99
CO <sub>2</sub>	52.4	0.0145	0.396	759	5.74	0.0574	7.65
N <sub>2</sub> O	52.7	0.0146	0.398	764	5.77	0.0577	7.70
SO <sub>2</sub>	63.0	0.0175	0.476	914	6.91	0.0691	9.21
Freon-12	83.2	0.0231	0.629	1210	9.12	0.0912	12.2
Xe	97.6	0.0271	0.738	1415.6	10.7	0.1070	14.24



## GAS FLOW CHARACTERISTICS

When selecting components for use in a gas system, certain factors must be considered which arise only because of the compressibility of the gaseous medium. The nature of gas compressibility is defined by the following two rules.

Boyle's Law – The pressure and specific volume of a gas are inversely proportional to each other under conditions of constant temperature.

Charles' Law – The pressure and temperature of a gas are directly proportional to each other when the volume is held constant, and the volume and temperature are directly proportional when the pressure is held constant.

Thus, a gas will expand to fill any container, and pressure and temperature will adjust to values consistent with the above rules. Gas flowing through valves and restrictors will be subject to an increasing specific volume as pressure drops take place, and temperatures will change as determined by the Joule-Thompson effect.

The combination of the above rules forms the basis for the "Equation of State" for perfect gases. This allows either pressure, temperature, or volume to be calculated for a known quantity of gas when the other two variables are known.

i.e.  $p V = m R T$  (See [page O52](#) for values of the Gas Constant, R)

In general, the following comments apply to gas flow.

1. Gas flow at high pressure ratios ( $P_1/P_2 > 1.9$ ) is directly proportional to the upstream absolute pressure (see [page O30](#)).
2. Gas flow at moderate pressure ratios ( $P_1/P_2 < 1.9$ ) is proportional to the downstream absolute pressure, and to the pressure differential (see [page O30](#)).



## GAS FLOW CHARACTERISTICS

3. Gas flow at low pressure ratios ( $P_1/P_2 < 1.1$ ) is proportional to the pressure differential, similar to hydraulic flow.
4. When restrictions appear in series, the most downstream restrictor dominates in the determination of flow rate.
5. When the absolute pressure ratio across a restrictor is above 1.9, the gas velocity will reach the speed of sound (sonic flow) in the restrictor throat. When restrictors appear in series the overall pressure ratio must be higher to achieve sonic flow.
6. When equal restrictors appear in series, sonic flow can only occur in the most downstream restrictor.
7. Velocity of the gas stream cannot exceed the speed of sound in either a constant area duct, or a converging section.

### The Rule of Forbidden Signals:\*

“The effect of pressure changes produced by a body moving at a speed faster than the speed of sound cannot reach points ahead of the body.”

This rule can be applied to pneumatic flow restrictors where the body is not moving, but the flow velocity relative to the body can reach, or exceed, the speed of sound. Whenever the downstream pressure is low enough to produce Mach 1 at the restrictor throat, any effect of changes in the downstream pressure cannot reach points upstream of the throat. Thus, flow rate will be independent of downstream pressure. This situation applies to a single orifice restrictor flowing air when the overall pressure ratio exceeds 1.89/1.

\*von Kármán, Jour. Aero. Sci., Vol. 14, No. 7 (1947)



## GAS FLOW ABSOLUTE PRESSURE MEASUREMENT

Gas flow is a function of upstream absolute pressure, and of the ratio of upstream to downstream pressures. Lohm testing done at The Lee Company is performed at an upstream pressure which is high enough so that downstream pressure does not affect the flow rate. To accurately determine the upstream absolute pressure, it is necessary to measure atmospheric pressure with a suitable barometer. This measurement will normally be in units of in. Hg, while the gauge pressure reading is in units of psig. Thus, the barometer reading must be converted to psia, and added to the gauge reading to get the value of pressure in psia.

$$\text{Pres. (psia)} = \text{Pres. (psig)} + 0.4912 \times \text{Pres. (in. Hg)}$$

**EXAMPLE:** What single-orifice restriction will permit a flow of 2.00 std L/min. of nitrogen at 70°F, with supply pressure at 10 psig, discharging to an atmospheric pressure of 29.5 in. Hg.

$$K = 276 \text{ (see page O32)}$$

$$T_1 = 70^\circ\text{F}, f_T = 1.00 \text{ (see page O31)}$$

$$P_2 = 0.4912 \times 29.5 = 14.5 \text{ psia}$$

$$P_1 = 10.0 + 14.5 = 24.5 \text{ psia}$$

$$P_1/P_2 = 24.5/14.5 = 1.69 \text{ (subsonic)}$$

$$\Delta P = 24.5 - 14.5 = 10.0 \text{ psid}$$

$$Q = 2.00 \text{ std L/min.}$$

$$L = \frac{2 (276) 1.0 \sqrt{10.0 (14.5)}}{2.00} = 3320 \text{ Lohms}$$



## GAS FLOW

### ACFM TO SCFM CONVERSION

It is frequently convenient to express gas flow in terms of flow at standard conditions. This is useful for calculation purposes, or for application to flow measuring instruments.

However, since most applications are not occurring under standard conditions, it may be necessary to convert the actual conditions to standard. The following formula can be used to convert actual flow rate to standard flow rate, in cubic feet per minute. Flow rate in other units can be determined by converting them into cubic feet per minute before and after using the formula.

$$\text{SCFM} = \text{ACFM} \left( \frac{P}{14.7} \right) \left( \frac{519}{460 + T} \right)$$

Where:

T = Gas temperature (°F)

P = Gas pressure (psia)

ACFM = Gas flow (actual cubic feet/minute)

SCFM = Gas flow (standard cubic feet/minute)

**EXAMPLE:** What is SCFM corresponding to 0.032 ACFM at 300 psia and at 240°F?

**SOLUTION:**

$$\text{SCFM} = 0.032 \left( \frac{300}{14.7} \right) \left( \frac{519}{700} \right) = 0.48$$

## GAS FLOW FLOW FACTOR (MULTI-ORIFICE)

When multiple orifices appear in series or when a restrictor has several stages, as in a visco Jet, there is a non-uniform distribution of the overall pressure drop through the restrictor. See [page O40](#) for additional discussion of series gas flow.

The effect of the above flow behavior is that the gas flow rate of a multi-orifice device is higher than would be expected from a single-orifice device of the same lohm rate, and at the same pressure conditions. This characteristic is reflected in the flow factor, " $f_M$ ," which reaches a maximum value of 1.3 at a pressure ratio of 3/1. See the graph on [page O39](#) for values of " $f_M$ ," at any pressure ratio for multi-orifice restrictors.

$$\text{Lohms} = \frac{K f_T f_M P_1}{Q} \quad (\text{Sonic condition})$$

**EXAMPLE:** What multi-orifice restriction will permit a flow of 0.5 std L/min. of hydrogen at 70°F, with supply pressure at 40 psig, discharging to atmosphere.

$$K = 1030 \text{ (see page O32)}$$

$$T_1 = 70^\circ\text{F}, \quad f_T = 1.0 \text{ (see page O31)}$$

$$P_1 = 40.0 + 14.7 = 54.7 \text{ psia}$$

$$P_2 = 14.7 \text{ psia}$$

$$P_1/P_2 = 54.7 / 14.7 = 3.72$$

$$f_M = 1.30 \text{ (see page O39)}$$

$$Q = 0.50 \text{ std L/min}$$

$$L = \frac{1030 \times 1.0 \times 1.30 \times 54.7}{0.50} = 146,000 \text{ Lohms}$$

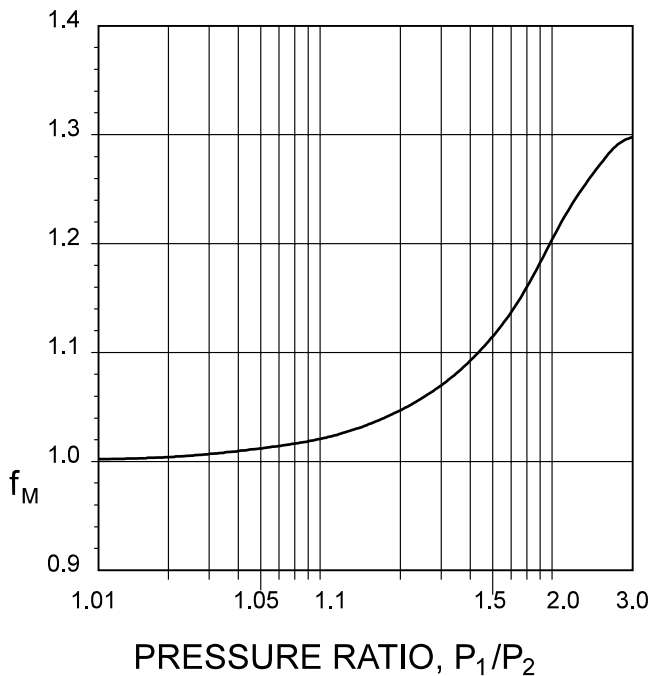

**GAS FLOW  
FLOW FACTOR “ $f_M$ ” (MULTI-ORIFICE)**

Sonic flow:

for  $P_1/P_2 > 3$ , use  $f_M = 1.3$

## GAS FLOW – COMBINATION OF RESTRICTIONS SERIES

When gas flow passes through orifices in series, the pressure drops are not evenly distributed. This is caused by the compressibility of the gas, and generally results in higher pressure drops at the downstream orifices. Thus, it becomes difficult to calculate the intermediate pressure between series restrictors flowing gas without using a trial and error process. To simplify this calculation, the chart on the following [page](#) may be used when the Lohm rates of the applicable restrictors are known.

The chart on the adjacent [page](#) solves for the absolute pressure between two orifices as a percentage of the supply pressure. To solve a problem, simply follow the graph line corresponding to the Lohm ratio,  $L_1/L_2$ , until it crosses the overall pressure ratio,  $P_1/P_3$ . Then read horizontally across to the left hand scale to obtain the value of  $P_2$  as a percentage of the upstream absolute pressure,  $P_1$ .

The following will allow solutions to be obtained for series restrictor problems even when Lohm or pressure ratios are off – scale:

1. When Lohm ratio is less than 0.1, then  $P_2 = P_1$ .
2. When Lohm ratio is less than 8.0, then solution for pressure ratio greater than 10, is the same as at 10.
3. When Lohm ratio is greater than 1.5, then solution at high values of pressure ratio is such that ratio  $P_2 / P_1$  is equal to the reciprocal of the Lohm ratio.



**GAS FLOW – COMBINATION OF RESTRICTIONS SERIES**

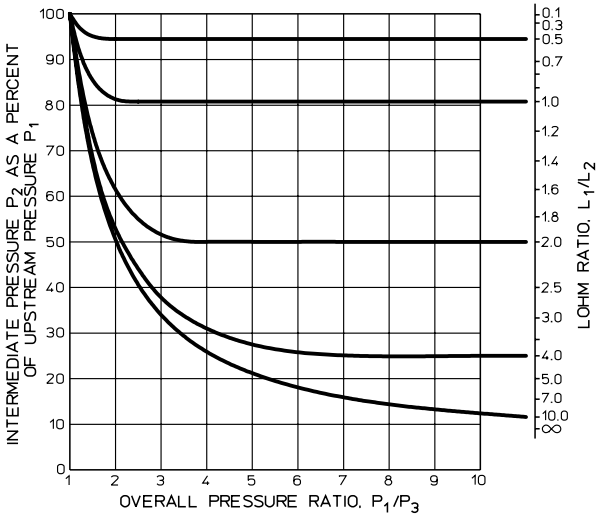
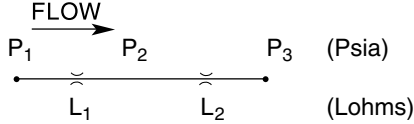

**EXAMPLE:** Find the intermediate pressure between two restrictors with an upstream pressure 72 psia, exhausting to atmosphere at 14.7 psia.

$L_1 = 2000 L_o.$

$L_2 = 500 L_o.$

Calculate the Lohm ratio:

$L_1/L_2 = 2000/500 = 4.0$

Calculate the overall pressure ratio:  $P_1/P_3 = 72.0/14.7 = 4.9$

Read 28% from left hand scale of graph.

The upstream pressure is known, thus:

$P_2 = 0.28 \times 72.0 = 20 \text{ psia}$



## GAS FLOW – COMBINATION OF RESTRICTIONS SERIES

The following formulas provide solutions to series gas flow problems which must be solved with more precision than can be obtained by use of the graph on [page O41](#). In each case, the graph can first be used to approximate the pressures upstream and downstream of each restriction, which can then be used to estimate whether the restrictions are creating sonic ( $P_1/P_2 \geq 1.9$ ) or subsonic ( $P_1/P_2 < 1.9$ ) flow conditions.

- 1.)  $L_1$  and  $L_2$  are both sonic and  $L_1 > L_2$  :

$$P_2 = P_1 \times \frac{L_2}{L_1}$$

- 2.)  $L_1$  is subsonic,  $L_2$  is sonic and  $L_1 \neq L_2$  :

$$P_2 = \frac{4 P_1 L_2^2}{L_1^2 + 4 L_2^2}$$

- 3.)  $L_1$  is subsonic,  $L_2$  is sonic and  $L_1 = L_2$  :

$$P_2 = 0.8 \times P_1$$

- 4.)  $L_1$  is sonic,  $L_2$  is subsonic and  $L_1 > L_2$  :

$$P_2 = P_3 + \frac{P_1^2 L_2^2}{4 P_3 L_1^2}$$

- 5.)  $L_1$  is subsonic,  $L_2$  is subsonic and  $L_1 \neq L_2$  :

$$P_2 = \frac{1}{2} \left[ P_1 - A + \sqrt{(P_1 - A)^2 + 4 P_3 A} \right], A = P_3 \left( \frac{L_1}{L_2} \right)^2$$

- 6.)  $L_1$  and  $L_2$  are both subsonic and  $L_1 = L_2$  :

$$P_2 = \frac{\Delta P_{1-3} + \sqrt{\Delta P_{1-3}^2 + 4 P_3^2}}{2}$$

## GAS FLOW – COMBINATION OF RESTRICTIONS SERIES

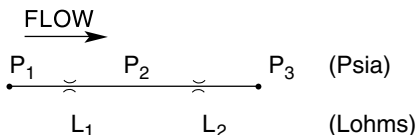

**EXAMPLE:** Find the intermediate pressure in the example problem on [page O40](#) with more precision.

$$L_1 = 2000 \text{ Lo.}, \quad L_2 = 500 \text{ Lo.}$$

$$P_1 = 72 \text{ psia}, \quad P_2 = 20 \text{ psia}, \quad P_3 = 14.7 \text{ psia}$$

$$P_1 / P_2 = 72 / 20 = 3.60 \quad (\text{Sonic})$$

$$P_2 / P_3 = 20 / 14.7 = 1.36 \quad (\text{Subsonic})$$

$$P_2 = P_3 + \frac{P_1^2 L_2^2}{4 P_3 L_1^2} = 14.7 + \frac{72^2 \times 500^2}{4 \times 14.7 \times 2000^2} = 20.2 \text{ psia}$$

**EXAMPLE:** Find the intermediate pressure between two restrictors with an upstream pressure of 30 psia, exhausting to atmosphere at 14.7 psia.

$$L_1 = 1500 \text{ Lo.}, \quad L_2 = 1500 \text{ Lo.}$$

Use solution procedure from [page O40](#) to determine approximate value of intermediate pressure,  $P_2$ :

$$L_1 / L_2 = 1500 / 1500 = 1.0, \quad P_1 / P_3 = 30.0 / 14.7 = 2.04$$

$$P_2 = 0.81 \times 30.0 = 24 \text{ psia. (approx.)}$$

$$P_1 / P_2 = 30.0 / 24.0 = 1.25, \quad P_2 / P_3 = 24.0 / 14.7 = 1.63$$

( $L_1$  and  $L_2$  are, therefore, both subsonic)

$$P_2 = \frac{\Delta P_{1-3} + \sqrt{\Delta P_{1-3}^2 + 4 P_3^2}}{2} = \frac{15.3 + \sqrt{15.3^2 + 4 \times 14.7^2}}{2}$$

$$P_2 = 24.2 \text{ psia}$$



## GAS FLOW – COMBINATION OF RESTRICTIONS PARALLEL

For parallel flow, the total Lohm rating is:

$$\frac{1}{L_T} = \frac{1}{L_1} + \frac{1}{L_2} + \frac{1}{L_3} + \dots + \frac{1}{L_N}$$

Note that this relationship is identical to that for liquid flow, and to the electrical equation.

### EXAMPLE:

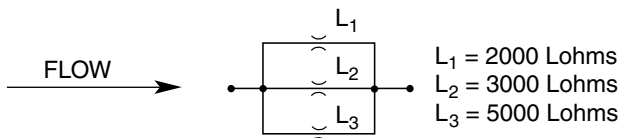

$$\frac{1}{L_T} = \frac{1}{2000} + \frac{1}{3000} + \frac{1}{5000} = 0.00103$$

Therefore,  $L_T = 970$  Lohms

## MOMENTUM FORCES – GAS FLOW

When a flowing stream of gas is subject to a change in velocity (either speed or direction), forces arise which are the reaction to the change in momentum of the stream. This is particularly important in valve design where the position of a moving element may be affected.

The direction in which the momentum force acts is always opposite to the acceleration which is imparted to the flow stream. The magnitude of the force may be calculated by using the momentum Lohm Laws which apply to air at near room temperature.

$$F = \frac{0.42 \times P_1}{L} \quad F = \frac{Q \text{ (slpm)}}{700} \text{ (sonic flow)}$$

**EXAMPLE:** Where a gas changes direction.

$$F = \frac{0.42 \times P_1}{L} = \frac{0.42 \times 1000}{2000} = 0.21 \text{ lbf.}$$

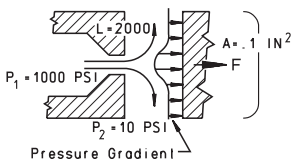

The momentum force of 0.21 lbs. in this example must be added to the force produced by static pressure on the plate ( $0.1 \text{ in.}^2 \times 10 \text{ psi} = 1 \text{ lb.}$ ) to give the total force on the plate.

**EXAMPLE:** Where a gas changes speed.

$$F = \frac{Q \text{ (slpm)}}{700} = \frac{35}{700} = 0.05 \text{ lbf.}$$

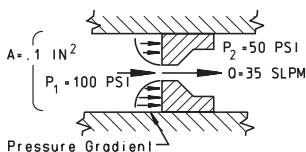

The momentum force of 0.05 lb. in this example must be subtracted from the force produced by static pressure on the plate ( $0.1 \text{ in.}^2 \times [100-50] = 5 \text{ lb.}$ ) to give the total force on the piston.



**TRANSIENT GAS FLOW**

This type of flow normally concerns the charging of a volume through a fixed resistance such as an orifice. Use of the Lohm system simplifies the calculation of the time required to blow down or charge up a vessel.

The first step is to calculate system time constant,  $\tau$ , which takes into consideration the type of gas, pressure–vessel volume, absolute temperature, and orifice Lohm rate. The system time constant is given by:

$$\tau = \frac{4 f_T V L}{K}$$

*Note: Select  $K$  from the appropriate “psia” column of the Volumetric Flow Table on [page O32](#). Keep the units of pressure vessel volume ( $V$ ) consistent with the volumetric flow units.*

The larger the value of  $\tau$ , the more sluggish the system.

Once  $\tau$  has been calculated, the ratio of upstream pressure to downstream pressure for both the initial and final conditions must be computed. Then, from the pressure–ratio graph, initial and final values for  $N$  can be found.  $N$  is the number of system time constants required for the system to reach equilibrium.

If the final condition is equilibrium, where upstream and downstream pressures are equal, the final pressure ratio is 1 and the final value of  $N$  is 0. With these values, the time for the system to blow down or charge up can be calculated from:

$$t = \tau (N_i - N_f)$$



**TRANSIENT GAS FLOW**

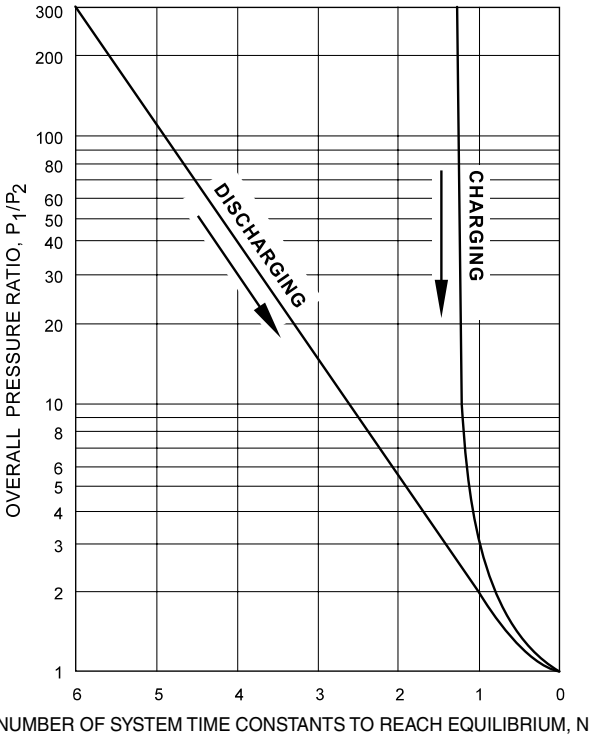

Where:

$K$  = Volumetric units correction factor

$L$  = Orifice Lohm rate, (Lohms)

$N_i$  = Initial number of system time constants

$N_f$  = Final number of system time constants

$P_1$  = Upstream gas pressure

$P_2$  = Downstream gas pressure

$f_T$  = Temperature factor

$t$  = Time to charge up or blow down a pressure vessel (sec.)

$V$  = Pressure vessel volume

$\tau$  = System time constant (sec.)



## TEMPERATURE CHANGE IN GAS FLOW

When a gas flows through an orifice it is subject to a throttling process. This results in the gas temperature changing to an extent determined by the pressure drop. Many of the common gasses will be chilled by throttling, although some gasses will increase in temperature.

A positive Joule – Thomson coefficient, which is a function of both temperature and pressure, will produce cooling of the gas. This is only the case at below the “inversion” temperature. At the inversion temperature, the Joule – Thomson coefficient is zero, so no heating or cooling occurs.

The following graph allows downstream temperature to be found when starting from an upstream pressure of 4500 psia; 750 psia for CO<sub>2</sub>. Solutions may be obtained for other upstream pressures by shifting the graph lines left or right so that the starting temperature (0° temp change) point of the curve corresponds to the actual upstream pressure.

The graph is entered on the zero “temp. change” line at the point corresponding to the actual upstream pressure. Then the graph line, or a parallel line, for the applicable gas, is followed to the right. When the value of the downstream pressure (read on the X-axis) is reached, the temperature change can be read on the Y-axis.

The graph works for a wide range of initial temperatures, but is most accurate when the initial temperature is close to 70°F.

Note that actual downstream temperature will not normally be as extreme as calculated due to heat transfer to or from the piping.



**TEMPERATURE CHANGE IN GAS FLOW**

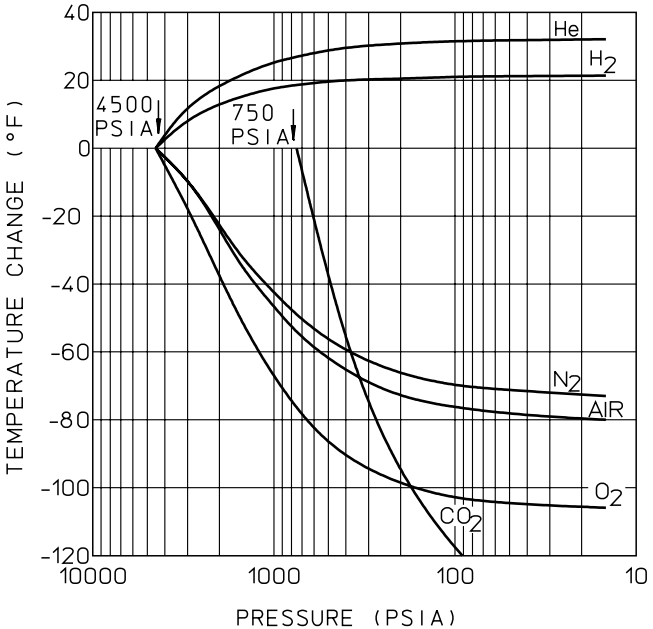

**EXAMPLE:**

A Lee Jet is used in a 4500 psia helium gas system to obtain a pressure drop down to 300 psia starting with an upstream temperature of 80°F. What downstream gas temperature will result?

Enter the graph at the 4500 psia point and follow the helium line to a pressure of 300 psia. Then read the temperature change on the left hand scale. This value is +30°F; thus, the calculated downstream temperature is 110°F.



**PNEUMATIC POWER**

A gas flowing through an orifice is throttled (causing turbulence and heating), and expanded (causing cooling). Thus, it is subject to energy conversions which reduce the amount of energy available to do work. The rate at which available energy is lost can be termed the pneumatic power, which is a function of the pressures, Lohm rate of the orifice, and the flow. For nitrogen, the relationship is shown on the accompanying graph.

When the flow rate and pressure ratio is known, the resulting power consumption can be determined from the graph. If flow is not known, it can be readily calculated from the Lohm rate using the gas Lohm Law. Simply enter the graph at the appropriate pressure ratio (X-axis), and read vertically to the line corresponding to the applicable flow rate. The resulting power may then be read horizontally across on the Y-axis. Note that pressure ratio is the ratio of the absolute pressures.

For more precise calculations, or to extend the range of the pneumatic power graph, the following formula may be used for nitrogen or air.

$$HP = \frac{2.2 P_1}{L} \left[ (P_1/P_2)^{1/4} - 1 \right]$$

Where:

HP = Pneumatic power (Horsepower)

$P_1$  = Absolute pressure upstream of orifice (psia)

$P_2$  = Absolute pressure downstream of orifice (psia)

L = Lohm rate of orifice (Lohms)

Note that due to compressor inefficiencies, more power will be needed to compress the gas than will be expended when it flows through an orifice.



## PNEUMATIC POWER

## POWER LOSS FOR NITROGEN

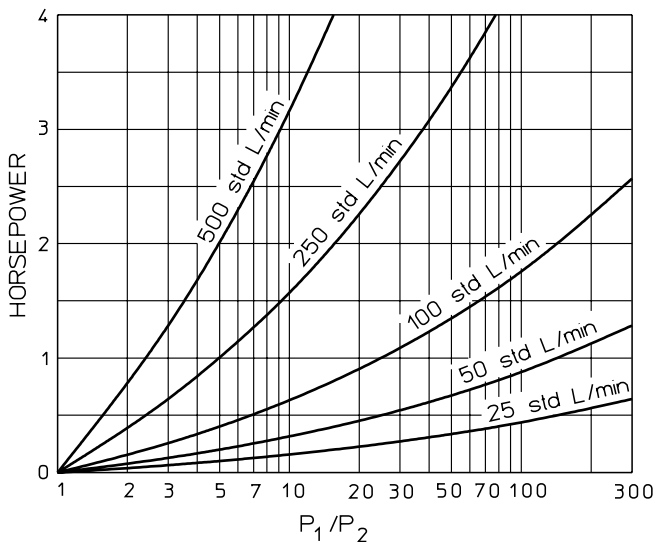
**EXAMPLE:**

For a 500 Lohm restrictor flowing nitrogen at 750 psia exhausting to 75 psia, the flow can be easily calculated from the gas Lohm Law.

$$Q = \frac{270 P_1}{L} = \frac{270 (750)}{500} = 405 \text{ std L/min.}$$

Next, determine the pressure ratio,  $P_1/P_2$ , which in this example is  $750/75 = 10$ . Then, from the graph:

$$\text{Pneumatic power} = 2.5 \text{ HP}$$



## GAS PROPERTIES

Gas	k	R ft lb/ lb°R	Density		C <sub>p</sub> * Btu/ lb° R	C <sub>v</sub> * Btu/ lb° R
			lb <sub>m</sub> /ft <sup>3</sup>	lb <sub>m</sub> /std L		
H <sub>2</sub>	1.40	766.6	0.00532	0.000188	3.420	2.435
He	1.66	386.1	0.01056	0.000373	1.250	0.754
Neon	1.66	76.6	0.0533	0.00188	0.248	0.150
Nat. Gas	1.22	79.2	0.0516	0.00182	0.560	0.45
N <sub>2</sub>	1.40	55.2	0.0739	0.00261	0.247	0.17
CO	1.41	55.2	0.0739	0.00261	0.243	0.172
Air	1.40	53.3	0.0764	0.00270	0.241	0.173
Ethane	1.21	51.4	0.0793	0.00280	0.386	0.320
O <sub>2</sub>	1.40	48.3	0.0845	0.00298	0.217	0.155
Argon	1.67	38.7	0.1053	0.00372	0.124	0.074
CO <sub>2</sub>	1.28	35.1	0.1162	0.00410	0.205	0.160
N <sub>2</sub> O	1.26	35.1	0.1162	0.00410	0.221	0.176
SO <sub>2</sub>	1.25	24.1	0.1691	0.00597	0.154	0.123
Freon-12	1.13	12.8	0.319	0.01127	0.145	0.129
Xe	1.68	11.74	0.3427	0.0121	0.0383	0.0228

\*values at 68°F and 14.7 psia

$c_p$  = Specific heat at constant pressure

$c_v$  = Specific heat at constant volume

k = Ratio of specific heats,  $\frac{c_p}{c_v}$

R = Gas Constant,  $\frac{R_o}{\text{Molecular. Wt.}}$



**DEFINITION**

The ROB Number, a system of rating the relative resistance to blockage of safety screens, has been developed to minimize the guesswork and expensive testing formerly involved in selecting a screen.

The ROB Number was conceived to aid system designers in choosing the optimum screen for their conditions relative to other screen options available. The ROB Number is not used to predict absolute screen life.

The ROB Number system is based on a few assumptions.

- The same contamination level applies for all screen options.
- Fluid contamination level is not affected by having a safety screen in the system.
- When particles block holes, the manner in which they block different size holes is essentially the same.
- Particle distribution follows a log - log<sup>2</sup> distribution.
- For best results the screen options should be of similar geometry and filtration media type.



A fluid contamination level per MIL-STD-1246 Class 200 was chosen as the basis of comparison with the ROB Number defined as;

$$ROB = \frac{N}{63.25n}$$

where  $n = 10^{(4.9029 - 0.926 \log^2 d)}$

$d$  = hole size ( $\mu$ )

$N$  = # of holes in a screen

A master screen of  $ROB = 1$  is therefore defined as having 1000 holes all 100  $\mu$  in size.

The following table gives the ROB Number for single holes of a given diameter. To determine the ROB Number for a screen, multiply the single hole value by the number of holes in the screen.

**Screen ROB # = Single orifice ROB # x # of holes.**

The screen safety factor is defined as the ratio of the screen ROB Number to the ROB Number of the orifice it is protecting. You should choose a screen to provide the highest practical safety factor.

**EXAMPLE:** Which safety screen would be the better choice to protect a 0.030 diameter orifice: A 0.008 hole size screen with 850 holes, or a 0.015 hole size screen with 450 holes?

**SOLUTION:** From the table on [page O56](#), we find that a single orifice of 0.030 diameter has a ROB Number of 9.7.

Again using the table for 0.008 and 0.015 holes and multiplying by the respective number of holes gives the following results:

	HOLE SIZE		# OF HOLES	ROB NUMBER	SAFETY FACTOR
	(in)	( $\mu$ )			
Orifice	0.030	762	1	9.7	1
Screen 1	0.008	203	850	14.4	1.5
Screen 2	0.015	381	450	131	13.5

The results show screen 2 to be the better choice.



SINGLE ORIFICE RO<sub>B</sub> NUMBERS

HOLE SIZE		SINGLE ORIFICE RO <sub>B</sub> #	HOLE SIZE		SINGLE ORIFICE RO <sub>B</sub> #
Inch	Micron		Inch	Micron	
0.0010	25	0.0000133	0.022	559	1.93
0.0015	38	0.0000408	0.023	584	2.42
0.0020	51	0.0000979	0.024	610	3.01
0.0025	64	0.000202	0.025	635	3.72
0.0030	76	0.000376	0.026	660	4.56
0.0035	89	0.000650	0.027	686	5.56
0.0040	102	0.00106	0.028	711	6.73
0.0045	114	0.00165	0.029	737	8.10
0.0050	127	0.00248	0.030	762	9.71
0.0055	140	0.00361	0.031	787	11.6
0.0060	152	0.00511	0.032	813	13.7
0.0065	165	0.00709	0.033	838	16.2
0.0070	178	0.00963	0.034	864	19.1
0.0075	191	0.0129	0.035	889	22.3
0.0080	203	0.0169	0.036	914	26.0
0.0085	216	0.0220	0.037	940	30.3
0.0090	229	0.0281	0.038	965	35.1
0.0095	241	0.0357	0.039	991	40.5
0.010	254	0.0448	0.040	1016	46.6
0.011	279	0.0687	0.041	1041	53.5
0.012	305	0.1023	0.042	1067	61.2
0.013	330	0.1482	0.043	1092	69.9
0.014	356	0.210	0.044	1118	79.5
0.015	381	0.291	0.045	1143	90.3
0.016	406	0.397	0.046	1168	102
0.017	432	0.533	0.047	1194	116
0.018	457	0.706	0.048	1219	130
0.019	483	0.922	0.049	1245	147
0.020	508	1.19	0.050	1270	165
0.021	533	1.52	0.051	1295	185

**SINGLE ORIFICE ROB NUMBERS**

HOLE SIZE		SINGLE ORIFICE ROB #	HOLE SIZE		SINGLE ORIFICE ROB #
Inch	Micron		Inch	Micron	
0.052	1321	207	0.082	2080	3.1E + 03
0.053	1346	231	0.083	2110	3.4E + 03
0.054	1372	257	0.084	2130	3.6E + 03
0.055	1397	286	0.085	2160	3.9E + 03
0.056	1422	318	0.086	2180	4.2E + 03
0.057	1448	352	0.087	2210	4.5E + 03
0.058	1473	390	0.088	2240	4.8E + 03
0.059	1499	431	0.089	2260	5.2E + 03
0.060	1524	476	0.090	2290	5.6E + 03
0.061	1549	525	0.091	2310	5.9E + 03
0.062	1575	578	0.092	2340	6.4E + 03
0.063	1600	635	0.093	2360	6.8E + 03
0.064	1626	698	0.094	2390	7.3E + 03
0.065	1651	765	0.095	2410	7.8E + 03
0.066	1676	838	0.096	2440	8.3E + 03
0.067	1702	917	0.097	2460	8.9E + 03
0.068	1727	1002	0.098	2490	9.5E + 03
0.069	1753	1094	0.099	2510	1.0E + 04
0.070	1780	1.2E + 03	0.10	2540	1.1E + 04
0.071	1800	1.3E + 03	0.11	2790	2.0E + 04
0.072	1830	1.4E + 03	0.12	3050	3.4E + 04
0.073	1850	1.5E + 03	0.13	3300	5.8E + 04
0.074	1880	1.7E + 03	0.14	3560	9.4E + 04
0.075	1910	1.8E + 03	0.15	3810	1.5E + 05
0.076	1930	2.0E + 03	0.16	4060	2.3E + 05
0.077	1960	2.1E + 03	0.17	4320	3.4E + 05
0.078	1980	2.3E + 03	0.18	4570	5.0E + 05
0.079	2010	2.5E + 03	0.19	4830	7.3E + 05
0.080	2030	2.7E + 03	0.20	5080	1.0E + 06
0.081	2060	2.9E + 03			



**RECOMMENDATIONS**

The Lee Company offers and strongly recommends protective screens integrally mounted on all of our products with small passageways less than 0.055" in diameter. Because our screens are small, we rely on our customers to provide adequate system filtration, leaving only the occasional "rogue" particle for our screens to catch.

The following table shows the typical tightest sliding fits and smallest metering orifices found in Lee Company standard products and the maximum recommended system filter micron rating needed to protect those products.

Min. Lee orifice diameter .....	0.005"
Min. Lee sliding fit (radial).....	0.0005" (12 $\mu$ )
Min. Lee integral screen hole size .....	0.004"
Max. system filter micron rating .....	10 $\mu$

Many Lee Company products have looser fits, larger orifices, or larger integral screens than those shown above. In such a case, coarser system filtration may be specified while still adequately protecting the Lee products. Our sales engineers stand ready to assist you in properly sizing your system filtration.

## CONTAMINATION LEVEL CORRELATION

Fluid contamination can be described by a number of techniques:

- The Gravimetric Method:  
The contaminant level is expressed as the mass of contaminant per unit volume of fluid.
- Parts Per Million:  
The degree of contamination is based on mass or volume per million units (e.g. gms/10<sup>6</sup> gms).

The above techniques describe bulk or total contamination but give little information regarding size of contaminant. For example, unless the size and density of the contaminating particles is known, no conclusions may be drawn relative to numbers of particles.

Other techniques look at numbers of particles, describing contamination in terms of its size and concentration. These may be an interval concentration, for example the number of contaminant particles (per unit volume) between 5 and 15  $\mu$  in size. Additionally, contamination may be expressed as a cumulative concentration. In this case contamination levels are described by the total number of particles per unit volume above a given size. For example, the number of particles above 25  $\mu$  in size per 100 mL.

Most commonly used cleanliness specifications are based on numbers of particles rather than gravimetric techniques. However, particle distributions which were determined to be representative of service distributions (e.g. NAS 1638 distributions) correlate reasonably with those obtained gravimetrically with AC test dust. The table on [page O60](#) (from An Encyclopedia of Fluid Contamination Control by E.C. Fitch) provides a correlation of some different cleanliness specifications.



CONTAMINATION LEVEL  
CORRELATION

ISO 4406 Code	Particles Per mL >10 $\mu$	ACFTD Gravimetric, Level mg/L	MIL-STD 1246 Level	NAS 1638 Class
6/23	140 000	1000		
25/23	85 000		1000	
23/20	14 000	100	700	
21/18	4 500			12
20/18	2 400		500	
20/17	2 300			11
20/16	1 400	10		
19/16	1 200			10
18/15	580			9
17/14	280		300	8
16/13	140	1		7
15/12	70			6
14/12	40		200	
14/11	35			5
13/10	14	.1		4
12/9	9			3
18/8	5			2
10/8	3		100	
10/7	2.3			1
10/6	1.4	.01		
9/6	1.2			0
8/5	0.6			00
7/5	0.3		50	
6/3	0.14	.001		
5/2	0.04		25	
2/.8	0.01		10	

## CONTAMINATION LEVEL CORRELATION

NAS* 1638	Number of Particles per 100 mL Micron Range					ISO 4406
Class	5-15 $\mu$	15-25 $\mu$	25-50 $\mu$	50-100 $\mu$	>100 $\mu$	Class
00	125	22	4	1	—	8/5
0	250	44	8	2	—	9/6
1	500	89	16	3	1	10/7
2	1K	178	32	6	1	11/8
3	2K	356	63	11	2	12/9
4	4K	712	126	22	4	13/10
5	8K	1425	253	45	8	14/11
6	16K	2.8K	506	90	16	15/12
7	32K	5.7K	1012	180	32	16/13
8	64K	11.4K	2.0K	360	64	17/14
9	128K	22.8K	4.1K	720	128	18/15
10	256K	45.6K	8.1K	1440	256	19/16
11	512K	91.2K	16.2K	2.8K	512	20/17
12	1M	182K	32.4K	5.8K	1024	21/18

• SAE standard AS 4059 also applies. This lists fluid particulate contamination cumulatively for 5 ranges:

- >2  $\mu$
- >5  $\mu$
- >15  $\mu$
- >25  $\mu$
- >50  $\mu$

for contamination classes from 000 to 12.



## PARTICLE SIZE COMPARISON

SIZES OF FAMILIAR OBJECTS		
SUBSTANCE	MICRON	INCH
Grain of Table Salt	100	0.0039
Human Hair	70	0.0028
Lower Limit of Visibility	40	0.0016
White Blood Cells	25	0.0010
Talcum Powder	10	0.0004
Red Blood Cells	8	0.0003
Bacteria (Average)	2	0.00008

SCREEN SIZES		
U.S. SIEVE NO.	OPENING IN INCHES	OPENING IN MICRONS
50	0.0117	297
60	0.0090	228
70	0.0083	210
100	0.0059	149
140	0.0041	105
200	0.0029	74
270	0.0021	53
325	0.0017	44
Paper	0.00039	10
Paper	0.00020	5

The restrictors and valves manufactured by The Lee Company may be classified by their “maximum working pressure differential” into four broad categories of 3,000, 4,000, 5,000, and 8,000 psi. These categories correspond generally to the common system pressures in use today.

Many applications do not expose the Lee Insert to the full system pressure differential. In such cases it may be possible for the designer to safely specify a Lee component with a lower working pressure differential than the system pressure. Our staff of sales engineers is ready to help you select the proper Lee Insert for your application.



**GOVERNMENT/INDUSTRY STANDARDS**

<b>FOR COMPONENTS (psi)</b>				
<b>MIL-H-8891A</b>				
Nominal System Pressure	3000	4000	5000	8000
System Peak Pressure	4050	5400	6750	9600
Proof Pressure	4500	6000	7500	12 000
Burst Pressure	7500	10 000	12 500	16 000

<b>FOR LINES, FITTINGS, HOSES and COUPLINGS<sup>†</sup> (psi)</b>				
<b>MIL-H-8891A</b>				
Nominal System Pressure	3000	4000	5000	8000
System Peak Pressure	4050	5400	6750	9600
Proof Pressure	6000	8000	10 000	16 000
Burst Pressure	12 000	16 000	20 000	24 000

† Lee Plugs should be selected to meet these requirements.



**RESTRICTORS**

PRODUCT	MAXIMUM WORKING PRESSURE (psid)			
	3000	4000	5000	8000
JETA	Pg. B16			
JEHA		Pg. B24		
JEKA	Pg. B26			
JEBA	Pg. B32			
VXCA	Pg. B34			
JEVA	Pg. B42			
VDCA	Pg. B46			
JHTA			Pg. B52	
JHHA			Pg. B56*	Pg. B56**
JHBA			Pg. B60, 64-69	Pg. B62
VHCA				Pg. B70
JHVA			Pg. B74	

\*Continuous    \*\* Intermittent

Lee Company Restrictors are designed to withstand transient pressure surges higher than the maximum working pressure differential. Continuous flow with low downstream pressure may be subjected to the effects of cavitation, and should be avoided. Further information on cavitation may be found on [pages B9](#) and [O29](#).

Max. Working Pressure (psid)	3000	4000	5000	8000
System Peak Pressure (psi)	4050	5400	6750	9600

Conventional hydrostatic proof and burst pressure testing applies equal pressure to all parts of a Lee restrictor. The Lee insert is therefore unaffected. Maximum hydrostatic pressure in this condition is limited only by the strength of the housing into which the Lee insert is installed.



## LEE CHEK AND RELIEF VALVES

PRODUCT	NOMINAL SYSTEM PRESSURE (psi)			
	3000	4000	5000	8000
CK 187 (Axial)	Pg. E8			
CK 250 (Axial)	Pg. E14			
CK 187 (Side Exit)		Pg. E20†		
CH 343 (Side Exit)			Pg. E24	
CS 187	Pg. E46			
CS 250 (Zero Leak)	Pg. E52			
CK 187 Lo-Lohm		Pg. E28††		
CK 250 Lo-Lohm	Pg. E32			
CK 375 Lo-Lohm	Pg. E34			
CK 500 Lo-Lohm	Pg. E36			
CK 500 (Hi-Q)			Pg. E40	
CK 750 (Hi-Q)			Pg. E42	
CK 1000 (Hi-Q)			Pg. E44	
CH 125				Pg. E58
CH 156			Pg. E64	
CH 187				Pg. E66
CH 250				Pg. E72
CH 375				Pg. E74
CH 500				Pg. E76
CP 250	Pg. E80			
RC 187	Pg. C6			
PR 187	Pg. F12			
PR 281	Pg. F20			
PR 375	Pg. F34			
PR 500	Pg. F36			
PH 281			Pg. F30	
PHR 375			Pg. F32	
PRT 187		Pg. F40		
PHT 250			Pg. F42	

† Flow rate limited (see pages E21 and E23).

†† Flow rate limited for screened, forward flow versions (see page E29).



These Lee Company check valve and relief valve products are rated for continuous system pressures in both the checked and flow directions. Relief valves are typically closed against system pressure and will be called upon to open on occasion and to flow at pressure differentials up to the system proof pressure.

Max. Working Pressure (psid)	3000*	4000*	5000	8000
System Proof Pressure (psi)	4500*	6000*	7500	12 000

\* See table on [page O66](#) for exceptions.

With pressure applied in the flowing direction, conventional hydrostatic proof and burst pressure testing applies equal pressure to all parts of a Lee check valve; and in the case of a pressure relief valve, a pressure differential equal to the shut off pressure will result. The Lee check or relief valve is therefore unaffected. Maximum hydrostatic pressure in this condition is limited only by the strength of the housing into which the Lee valve is installed.

A hydrostatic test for proof or burst pressure applied in the opposite direction (i.e. the checked direction) will stress the Lee check or pressure relief valve.



## STANDARD SHUTTLE VALVES AND FLOW CONTROL VALVES

PRODUCT	NOMINAL SYSTEM PRESSURE (psi)			
	3000	4000	5000	8000
SV 187/SH 187		Pg. G6*	Pg. G14	
SV 281/SH 281		Pg. G8*	Pg. G16	
SV 500/SH 500		Pg. G12*	Pg. G20	
FC 187	Pg. C8			
FC 281	Pg. C10			
FC 375/FH 375	Pg. C12			Pg. C20
FC 500/FH 500	Pg. C14			Pg. C24
FL 281	Pg. C26			
FL 500	Pg. C28			

\* Flow rate limited (see [Section G](#)).

Lee Company Shuttle Valves have the same continuous system pressure rating for both normal and emergency modes of operation.

Lee Company Flow Control Valves have the same continuous system pressure rating for both the metered flow and the free flow directions. Continuous flow with low downstream pressure may cause cavitation, and should be avoided. Further information on cavitation may be found on [pages B9](#) and [O29](#).

Nominal System Pressure (psi)	3000	4000	5000	8000
System Peak Pressure (psi max.)	4050	5400	6750	9600

For Lee Company Shuttle Valves, a hydrostatic test for proof or burst pressure applied at either the normal or emergency port (with the cylinder port capped) will stress the valve. Proof and burst ratings are the same for both cases.

For Lee Flow Control Valves, conventional hydrostatic proof and burst pressure testing applies equal pressure to all parts of a flow control insert. The Lee insert is therefore

unaffected. Maximum hydrostatic pressure in this condition is limited only by the strength of the housing into which the Lee insert is installed.

Nominal System Pressure (psi)	3 000	4 000	5 000	8 000
Proof Pressure (psi)	6 000	7 000	7 500	12 000
Burst Pressure (psi)	10 000	11 000	12 500	16 000

**STANDARD LINE MOUNTS**

PRODUCT	MAXIMUM WORKING PRESSURE (psid)			
	3000	4000	5000	8000
Style "B" AS4395 Ends	Pg. L6 Pg. L9			
Style "C" AS4375 Ends	Pg. L6 Pg. L9			
Style "E" AS4395 Ends	Pg. L7 Pg. L10			
Style "F" AS4375 Ends	Pg. L7 Pg. L10			
Style "G" AS85720/1 Ends				Pg. L8 Pg. L11
Style "H" AS85720/1 Ends				Pg. L12
Ring Locked Adapters		Pg. L20-L51	Pg. L20-L51	
VXLA	Pg. L13-L14			
VDLA	Pg. L15-L17			

The maximum working pressure differential, and the transient surge pressure of the fitting, is limited by, and is a function of, the Lee insert that is installed in the fitting.

Max. Working Pressure (psid)	3 000	4 000	5 000	8 000
Proof Pressure (psi)	6 000	8 000	10 000	16 000
Burst Pressure (psi)	12 000	16 000	20 000	24 000



**PRIMARY STANDARDS\***

- Meter* Length equal to 1,650,763.73 wavelengths in vacuum of the radiation corresponding to the transition between the levels  $2 p_{10}$  and  $5 d_5$  of the krypton-86 atom.
- Kilogram* Mass equal to the mass of the international prototype of the kilogram. This is a particular cylinder of platinum-iridium alloy which is preserved in a vault at Sevres, France by the International Bureau of Weights and Measures.
- Second* Time duration of 9,192,631,770 periods of the radiation corresponding to the transition between the two hyperfine levels of the ground state of the cesium-133 atom.

**DERIVED STANDARD**

- Newton* Force which gives to a mass of 1 kilogram an acceleration of 1 meter per sec. per sec.

**EXACT CONVERSIONS\***

- |                      |   |
|----------------------|---|
| 1 pascal             | = 1 newton/meter <sup>2</sup>                       |
| 1 atmosphere         | = 101 325 pascals                                   |
| 1 bar                | = 100 000 pascals                                   |
| 1 centipoise         | = 0.001 newton-second/meter <sup>2</sup>            |
| 1 centistoke         | = $1 \times 10^{-6}$ meter <sup>2</sup> /second     |
| 1 fluid ounce (U.S.) | = $2.95735295625 \times 10^{-5}$ meter <sup>3</sup> |
| 1 foot               | = 0.3048 meter                                      |
| 1 gallon (U.S.)      | = $3.785411784 \times 10^{-3}$ meter <sup>3</sup>   |
| 1 gram               | = 0.001 kilogram                                    |
| 1 inch               | = 0.0254 meter                                      |
| 1 kilogram force     | = 9.80665 newtons                                   |
| 1 liter              | = 0.001 meter <sup>3</sup>                          |
| 1 micron             | = $1 \times 10^{-6}$ meter                          |
| 1 milliliter         | = $1 \times 10^{-6}$ meter <sup>3</sup>             |
| 1 ounce mass (avdp)  | = 0.028349523125 kilogram                           |
| 1 pound force (avdp) | = 4.4482216152605 newtons                           |
| 1 pound mass (avdp)  | = 0.45359237 kilogram                               |

\*Exact by National Bureau of Standards definition

**DERIVED CONVERSIONS:**

1 foot of H <sub>2</sub> O at 4°C	= 2988.98 pascals
1 gram/centimeter <sup>3</sup>	= 1 000 kilograms/meter <sup>3</sup>
1 inch of H <sub>2</sub> O at 4°C	= 249.082 pascals
1 inch of Hg at 0°C	= 3386.389 pascals
1 pound <sub>F</sub> /inch <sup>2</sup>	= 6894.7572 pascals
1 pound <sub>M</sub> /inch <sup>3</sup>	= 27,679.905 Kilograms/meter <sup>3</sup>
1 quart (U.S.)	= 9.4635295 x 10 <sup>-4</sup> meter <sup>3</sup>
1 drop	= 50 microliters
1 bar	= 14.503774 pound <sub>F</sub> /inch <sup>2</sup>

**CONVERSION FACTORS****MASS**

To Convert	Into	LB <sub>M</sub> (avdp)	OZ <sub>M</sub> (avdp)	SLUG	gram	kg <sub>m</sub>
<b>LB<sub>M</sub> (avdp)</b>	—	16.00	$3.108 \times 10^{-2}$	453.6	0.4536	
<b>OZ<sub>M</sub> (avdp)</b>	$6.250 \times 10^{-2}$	—	$1.943 \times 10^{-3}$	28.35	$2.835 \times 10^{-2}$	
<b>SLUG</b>	32.17	514.8	—	$1.459 \times 10^4$	14.59	
<b>gram</b>	$2.205 \times 10^{-3}$	$3.527 \times 10^{-2}$	$6.852 \times 10^{-5}$	—	$1.000 \times 10^{-3}$	
<b>kg<sub>m</sub></b>	2.205	35.27	$6.852 \times 10^{-2}$	1000	—	

Multiply by 

## CONVERSION FACTORS

## VOLUME

Into To Convert	FT. <sup>3</sup>	IN. <sup>3</sup>	GAL. (U.S.)	QUART (U.S.)	FL.OZ. (U.S.)	liter	mL	m <sup>3</sup>
FT. <sup>3</sup>	—	1728	7.481	29.92	957.5	28.32	2.832 x 10 <sup>4</sup>	2.832 x 10 <sup>-2</sup>
IN. <sup>3</sup>	5.787 x 10 <sup>-4</sup>	—	4.329 x 10 <sup>-3</sup>	1.732 x 10 <sup>-2</sup>	0.5541	1.639 x 10 <sup>-2</sup>	16.39	1.639 x 10 <sup>-5</sup>
GAL. (U.S.)	0.1337	231.0	—	4.000	128.0	3.785	3785	3.785 x 10 <sup>-3</sup>
QUART (U.S.)	3.342 x 10 <sup>-2</sup>	57.75	0.2500	—	32.00	0.9464	946.4	9.464 x 10 <sup>-4</sup>
FL.OZ. (U.S.)	1.044 x 10 <sup>-3</sup>	1.805	7.813 x 10 <sup>-3</sup>	3.125 x 10 <sup>-2</sup>	—	2.957 x 10 <sup>-2</sup>	29.57	2.957 x 10 <sup>-5</sup>
liter	3.531 x 10 <sup>-2</sup>	61.02	0.2642	1.057	33.81	—	1000	1.000 x 10 <sup>-3</sup>
mL	3.531 x 10 <sup>-5</sup>	6.102 x 10 <sup>-2</sup>	2.642 x 10 <sup>-4</sup>	1.057 x 10 <sup>-3</sup>	3.381 x 10 <sup>-2</sup>	1.000 x 10 <sup>-3</sup>	—	1.000 x 10 <sup>-6</sup>
m <sup>3</sup>	35.31	6.102 x 10 <sup>4</sup>	264.2	1057	3.381 x 10 <sup>4</sup>	1000	1.000 x 10 <sup>6</sup>	—

Multiply by  $\uparrow$

## CONVERSION FACTORS

## PRESSURE

	LB. IN. <sup>2</sup>	IN. HG at 0°C	IN. H <sub>2</sub> O at 4°C	FT. H <sub>2</sub> O at 4°C	ATM	kgF cm <sup>2</sup>	kgF m <sup>2</sup>	kPa
LB. IN. <sup>2</sup>	—	2.036	27.68	2.307	$6.805 \times 10^{-2}$	$7.031 \times 10^{-2}$	703.1	6.895
IN. HG at 0°C	0.4912	—	13.60	1.133	$3.342 \times 10^{-2}$	$3.453 \times 10^{-2}$	345.3	3.386
IN. H <sub>2</sub> O at 4°C	$3.613 \times 10^{-2}$	$7.355 \times 10^{-2}$	—	$8.333 \times 10^{-2}$	$2.458 \times 10^{-3}$	$2.540 \times 10^{-3}$	25.40	0.2491
FT. H <sub>2</sub> O at 4°C	0.4335	0.8826	12.00	—	$2.950 \times 10^{-2}$	$3.048 \times 10^{-2}$	304.8	2.989
ATM	14.70	29.92	406.8	33.90	—	1.033	$1.033 \times 10^4$	101.3
kgF cm <sup>2</sup>	14.22	28.96	393.7	32.81	0.9678	—	$1.000 \times 10^4$	98.07
kgF m <sup>2</sup>	$1.422 \times 10^{-3}$	$2.896 \times 10^{-3}$	$3.937 \times 10^{-2}$	$3.281 \times 10^{-3}$	$9.678 \times 10^{-5}$	$1.000 \times 10^{-4}$	—	$9.807 \times 10^{-3}$
kPa	0.1450	0.2953	4.015	0.3346	$9.869 \times 10^{-3}$	$1.020 \times 10^{-2}$	102.0	—

Into  
To  
Convert

Multiply by

**CONVERSION FACTORS - VOLUME TO MASS  
WATER AT 39.2°F (4°C)****MASS**

	To Convert	Into				
		LB. <sub>M</sub> (avdp)	OZ. <sub>M</sub> (avdp)	SLUG	gram	kg <sub>m</sub>
<b>V O L U M E</b>	FT. <sup>3</sup>	62.43	998.8	1.940	2.832 x 10 <sup>4</sup>	28.32
	IN. <sup>3</sup>	3.613 x 10 <sup>-2</sup>	0.5780	1.123 x 10 <sup>-3</sup>	16.39	1.639 x 10 <sup>-2</sup>
	GALLON (U.S.)	8.345	133.5	0.2594	3785	3.785
	QUART (U.S.)	2.086	33.38	6.484 x 10 <sup>-2</sup>	946.3	0.9463
	FL.OZ. (U.S.)	6.520 x 10 <sup>-2</sup>	1.043	2.026 x 10 <sup>-3</sup>	29.57	2.957 x 10 <sup>-2</sup>
	liter	2.205	35.27	6.852 x 10 <sup>-2</sup>	1000	1.000
	mL	2.205 x 10 <sup>-3</sup>	3.527 x 10 <sup>-2</sup>	6.852 x 10 <sup>-5</sup>	1.000	1.000 x 10 <sup>-3</sup>
	m <sup>3</sup>	2205	3.527 x 10 <sup>4</sup>	68.52	1.000 x 10 <sup>6</sup>	1000

Multiply by  $\uparrow$ 

**NOTE:** For application of these factors to fluids with specific gravity other than 1.0, these factors must be multiplied by the actual specific gravity.

**EXAMPLE:**

*Problem:* Determine the flow rate in lb./hr. which is equivalent to 430 mL/min. Fluid is MIL-H-5606 (Specific gravity is 0.84).

*Solution:*

$$430 \frac{\text{mL}}{\text{min}} \times 2.20 \times 10^{-3} \frac{\text{lb}}{\text{mL}} \times 0.84 \times \frac{60 \text{ min}}{1 \text{ hr}} = 47.8 \frac{\text{lb}_m}{\text{hr}}$$

**CONVERSION FACTORS - MASS TO VOLUME  
WATER AT 39.2°F (4°C)**

		<b>MASS</b>				
		LB <sub>M</sub> (avdp)	OZ <sub>M</sub> (avdp)	SLUG	gram	kg <sub>m</sub>
V O L U M E	To Convert ↓ Into	→				
	FT. <sup>3</sup>	1.602 x 10 <sup>-2</sup>	1.001 x 10 <sup>-3</sup>	0.5154	3.532 x 10 <sup>-5</sup>	3.532 x 10 <sup>-2</sup>
	IN. <sup>3</sup>	27.68	1.730	890.6	6.103 x 10 <sup>-2</sup>	61.03
	GALLON (U.S.)	0.1198	7.489 x 10 <sup>-3</sup>	3.855	2.642 x 10 <sup>-4</sup>	0.2642
	QUART (U.S.)	0.4793	2.996 x 10 <sup>-2</sup>	15.42	9.464 x 10 <sup>-4</sup>	0.9464
	FL.OZ. (U.S.)	15.34	0.9586	493.5	3.381 x 10 <sup>-2</sup>	33.81
	liter	0.4536	2.835 x 10 <sup>-2</sup>	14.59	1.000 x 10 <sup>-3</sup>	1.000
	mL	453.6	28.35	1.459 x 10 <sup>4</sup>	1.000	1000
	m <sup>3</sup>	4.536 x 10 <sup>-4</sup>	2.835 x 10 <sup>-5</sup>	1.459 x 10 <sup>-2</sup>	1.000 x 10 <sup>-6</sup>	1.000 x 10 <sup>-3</sup>

Multiply by ↗

**NOTE:** For application of these factors to fluids with specific gravity other than 1.0, these factors must be divided by the actual specific gravity.

**EXAMPLE:**

*Problem:* Determine the volume in gallons which would be occupied by 3.0 kg of sea water (Specific gravity is 1.02).

*Solution:*

$$3.0 \text{ kg} \times \frac{0.2642}{1.02} \frac{\text{GAL.}}{\text{kg}} = 0.78 \text{ GAL.}$$



## TEMPERATURE CONVERSION

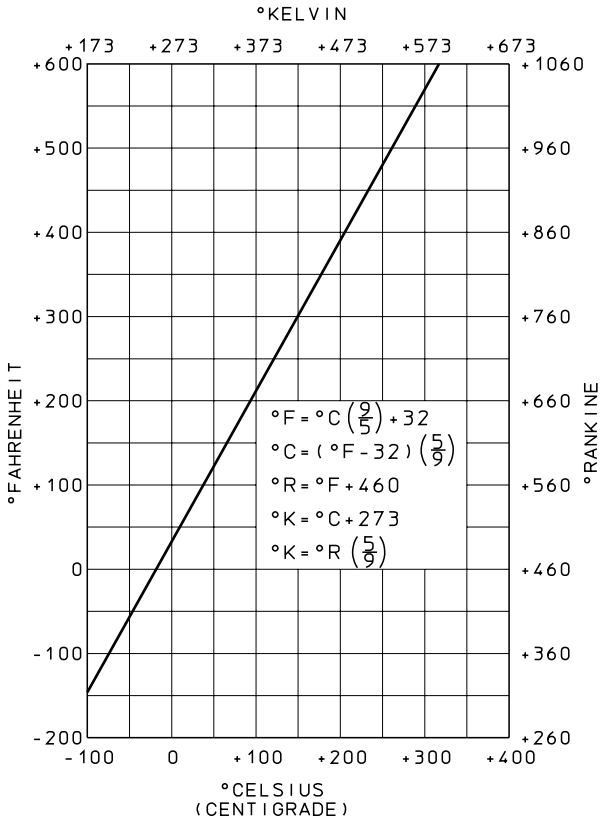

VISCOSITY CONVERSION

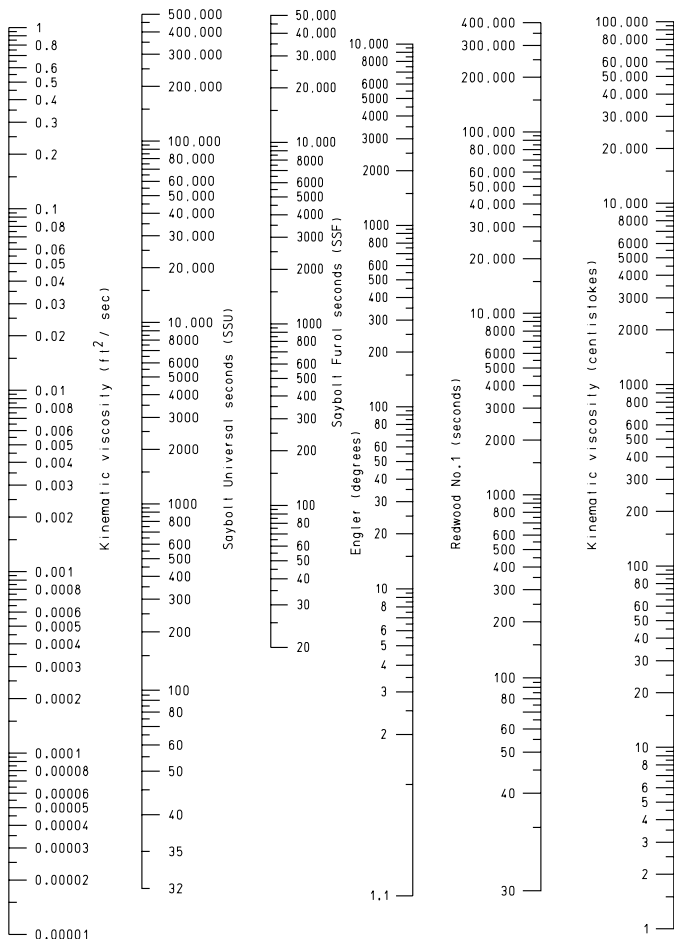

## TORQUE CONVERSION CHART

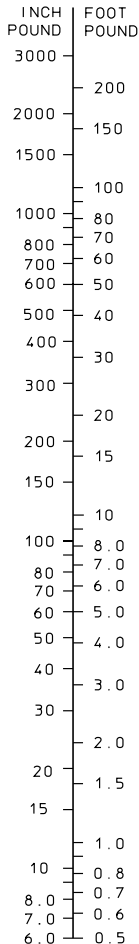
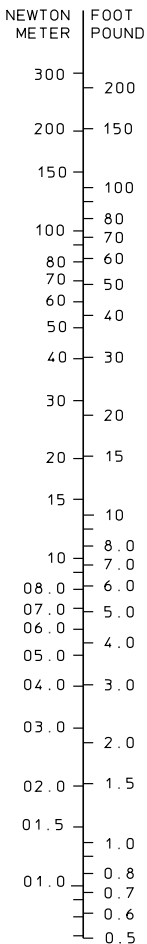

CONNECT HORIZONTALLY



## PRESSURE CONVERSION CHART

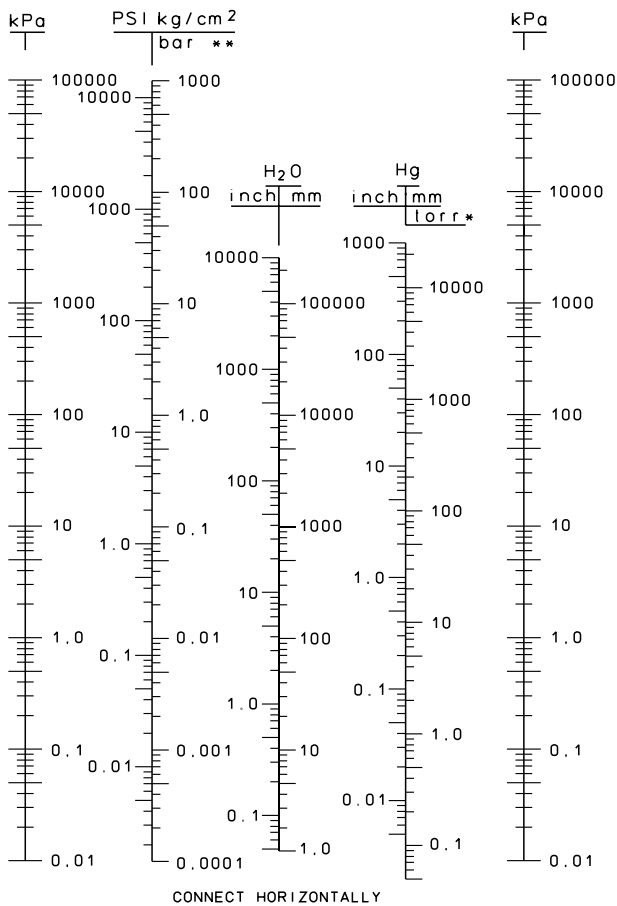

NOTE: \* 1 torr = 1 mm Hg = 0.535 inch H<sub>2</sub>O

\*\* 1 bar = 1.02 kg/cm<sup>2</sup> = 14.5 PSI

1 PSI = 6.895 kPa = 0.07031 kg/cm<sup>2</sup>



## GRAPHIC SYMBOLS FOR HYDRAULICS AND PNEUMATICS

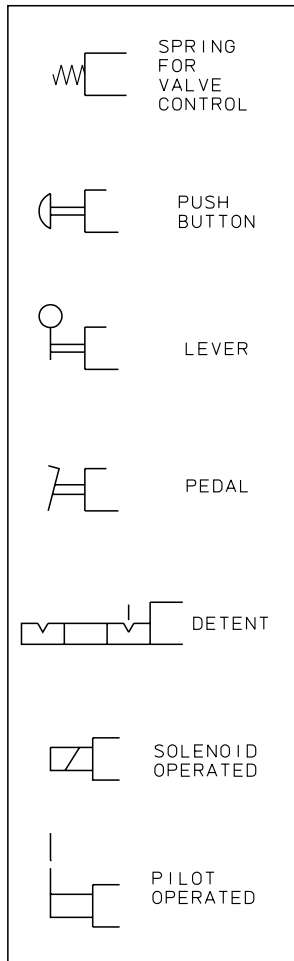
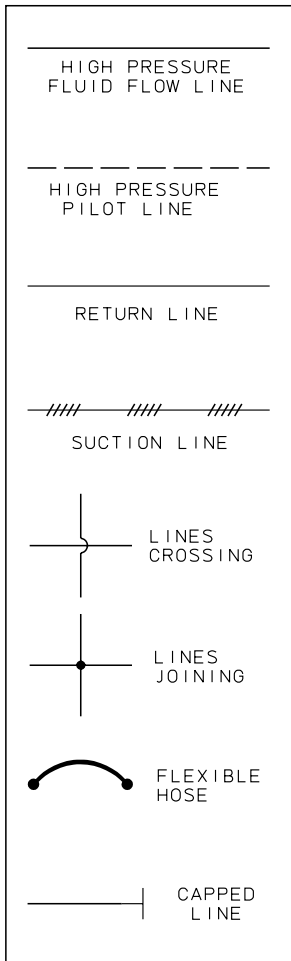

**GRAPHIC SYMBOLS  
FOR HYDRAULICS AND PNEUMATICS**

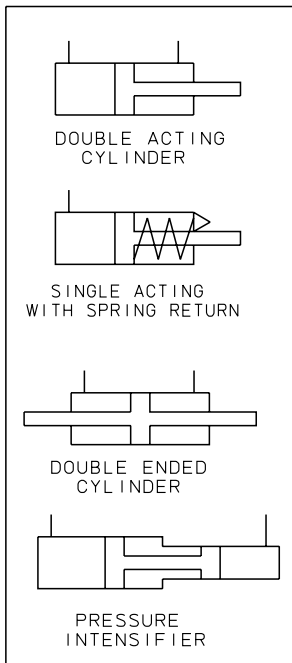
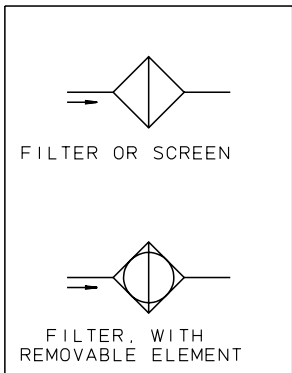
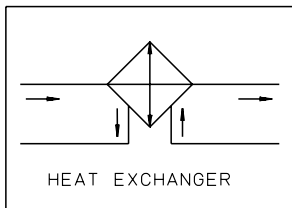
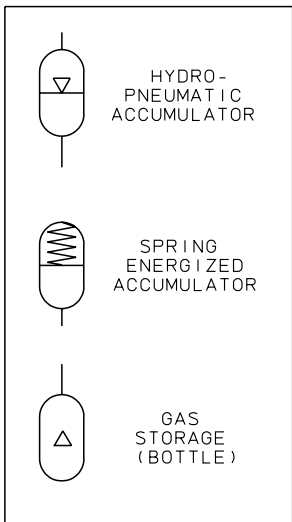

## GRAPHIC SYMBOLS FOR HYDRAULICS AND PNEUMATICS

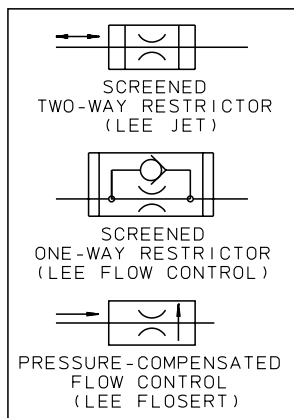
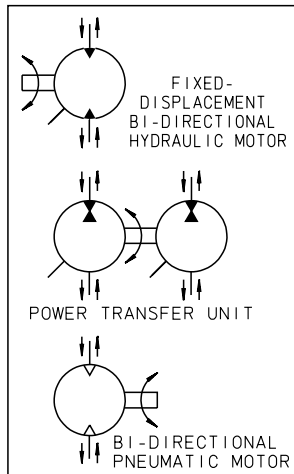
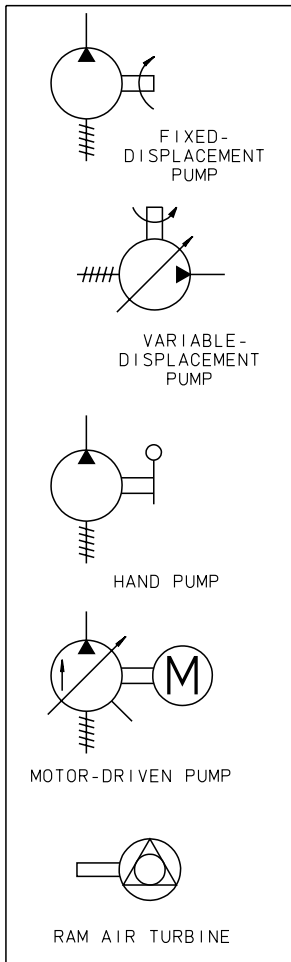

**GRAPHIC SYMBOLS  
FOR HYDRAULICS AND PNEUMATICS**

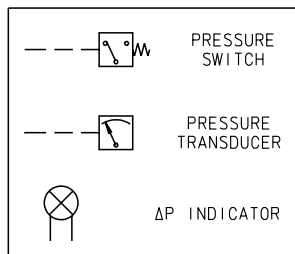
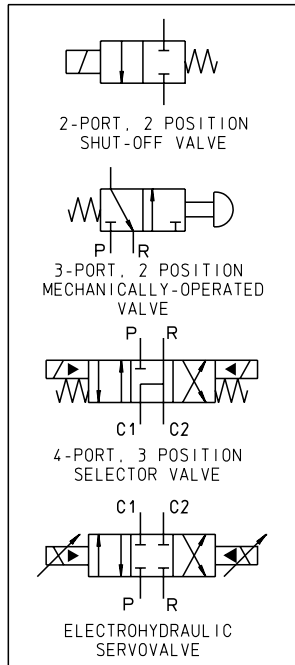
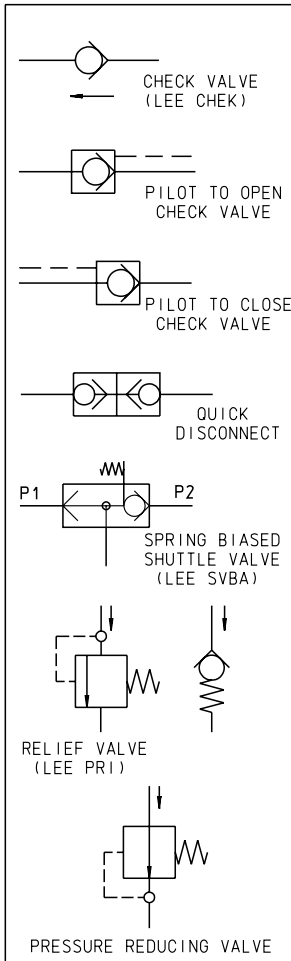

**METRIC DIMENSIONS OF  
LEE HYDRAULIC INSERTS**

	DIMENSION (Inches)		METRIC DIMENSION (mm)	
	Max.	Min.	Max.	Min.
<b>STANDARD BODY DIAMETERS</b>	0.1249	0.1242	3.175	3.155
	0.1561	0.1554	3.965	3.945
	0.1874	0.1867	4.760	4.740
	0.2499	0.2492	6.350	6.330
	0.2811	0.2804	7.140	7.120
	0.3749	0.3742	9.525	9.505
	0.4999	0.4992	12.700	12.680
<b>OVERSIZE BODY DIAMETERS</b>	0.1349	0.1342	3.430	3.410
	0.1661	0.1654	4.220	4.200
	0.1974	0.1967	5.015	4.995
	0.2599	0.2592	6.605	6.585
	0.2911	0.2904	7.395	7.375
	0.3849	0.3842	9.780	9.760
	0.5099	0.5092	12.955	12.935

**DEFINITIONS OF VISCOSITY**

- *Absolute Viscosity* is the ratio of the shear stress in a fluid to the rate of shearing strain.
- *Unit of absolute viscosity* in the metric system: poise and centipoise;
  - 1 poise = 1 gm/(cm)(sec.)
  - 1 centipoise = 1/100 poise
- *Unit of absolute viscosity* in the English system: slug/(ft.) (sec.); 1 slug/(ft.)(sec.) = 478.8 poise
- *Kinematic Viscosity* is the absolute viscosity ÷ density.
- *Unit of kinematic viscosity* in the metric system (and commonly used in the countries using the English system): stoke and centistoke;
  - 1 stoke = 1 poise/density (gm/ml)
  - 1 centistoke = 1/100 stoke
- *Other units of kinematic viscosity*; In the English system, the most practical unit for making calculations is ft.<sup>2</sup>/sec.;
  - 1 ft.<sup>2</sup>/sec. = 92903 centistokes
  - 1 centistoke = 1/076 x 10<sup>-5</sup> ft.<sup>2</sup>/sec.
- *Saybolt Universal Seconds*, SSU, is the kinematic viscosity as determined by the time in seconds required for 60 cc of fluid to flow through a standard orifice.
- *Saybolt-Furol*, SSF, utilizes a larger orifice and is used for very viscous fluids. Time of efflux is approx. 1/10 that of Universal.
- *Engler* degrees are obtained by dividing the outflow time of a specified amount of fluid through a specified orifice by the outflow time of water at 68°F. The method is used predominantly in European countries.
- *Viscosity Index* is an empirical number indicating the effect of temperature change on viscosity. Fluids with the same viscosity at a given temperature do not necessarily have the same viscosity index.
- *SAE Viscosity Numbers* are a means of classifying crankcase lubricating oils in terms of viscosity. Other factors are not considered.

NOTE: See [page O77](#) for conversions.



## MARKING OF STANDARD LEE INSERTS

In order to provide complete traceability of our products, The Lee Company individually marks each standard insert, with the exception of Lee Plugs, with the appropriate twelve character part number and six digit lot number. For special products, additional information such as serial number, flow rate, etc., can be provided depending upon individual customer requirements. Examples of the standard marking are shown below for a typical restrictor insert, valve insert, and a restrictor installed in a union.

### RESTRICTOR INSERT



### VALVE INSERT

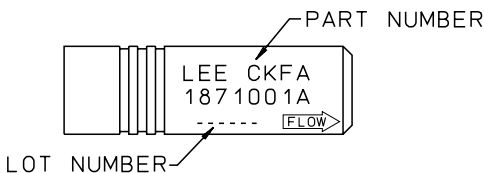

### RESTRICTOR INSERT IN A UNION

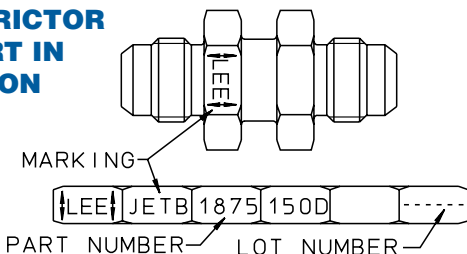

## **POLICY FOR SPECIALLY FABRICATED PARTS**

The Lee Company offers a wide range of off-the-shelf catalog components to help designers find the solutions to their problems. Should you need a non-standard component, The Lee Company will be pleased to design products not listed in this handbook. We have the capability to design and manufacture variations to the components listed in this handbook on a prototype basis and for future production.

A unique part number would be assigned to the design. The subsequent purchase of this part number would be reserved for the originator exclusively.

If a Production Preparation Charge (PPC) is necessary to partially offset the non-recurring costs of design, manufacturing, testing or tooling, the design of this special part will be the property of The Lee Company.

## **PROPRIETARY RIGHTS**















The Lee Company retains all proprietary rights and the exclusive right to manufacture the products shown in this technical hydraulic handbook, as well as any specially designed products. Unlimited rights, as described in DAR 7-104.9(b), are *not* transferred to the buyer.

## **EXPORT COMPLIANCE**















The Lee Company complies with the laws and regulations of the United States of America (USA) relating to exports and foreign transactions, including, but not limited to, the International Traffic in Arms Regulations (ITAR) (22 C.F.R. Parts 120-130), the Arms Export Control Act (22 U.S.C. 2778), The Export Administration Regulation (EAR)( 15 C.F.R. Parts 730-774), the Office of Foreign Asset Controls (OFAC) (31 C.F.R. 501-598) and the Export Administration Act of 1979, as amended (50 U.S.C. 2401 et seq). Please visit our web site at [www.theleeco.com](http://www.theleeco.com) for more information.



## TRADEMARKS OF THE LEE COMPANY

PRODUCT NAME	TRADEMARK	PRODUCT NAME	TRADEMARK
Lee Plug <sup>®</sup>		LeeJet Bender <sup>®</sup>	
Lee Plug RFO <sup>®</sup>		Lee Axial Visco Jet <sup>®</sup>	
Lee Jet <sup>®</sup>		Lee JEVA <sup>®</sup>	
Lee Hi Watt Jet <sup>®</sup>		Lee Visco Jet <sup>®</sup>	
Lee kW Jet <sup>®</sup>		Lee Cro <sup>®</sup>	
Lee Micro Jet <sup>™</sup>		Lee Restrictor Chek <sup>®</sup>	
Lee Hydamp <sup>®</sup>		Lee Plug Jet <sup>®</sup>	

## TRADEMARKS OF THE LEE COMPANY

PRODUCT NAME	TRADEMARK	PRODUCT NAME	TRADEMARK
Lee Flow Control		Lee Tri	
Lee Flosert		Lee Shuttle Valve	
Lee Spin Jet®		Lee Safety Screens	
Lee JELA®		Lee HI-BAR® Screens	
LeeChek®		Lee Micro Damp™	
Lee Pri		Lee Kipster	
Lee TWIS		The Lee Company	



**PATENTS • TRADEMARKS • COPYRIGHTS**

1. Throughout the text of this handbook, The Lee Company has referred to these hydraulic inserts by their trade names and trade marks. Many of these devices are covered by U.S.A. and foreign Patents – issued, pending, or applied for.
2. Permission is hereby granted to use, copy and reproduce the general engineering material, including nomograms, tables and formulas, with the only restriction being to give credit to The Lee Company if the material is published or republished.
3. It is the clear intent of The Lee Company to encourage all members of the engineering profession to use the Lohm System, whether they are customers or competitors or others who could benefit from its use. Credit to The Lee Company must be stated in all publications.

**WARRANTY**

The Lee Company is proud to warrant that all items described in this handbook are free from defect in design, workmanship and materials and that they conform to any applicable specifications, drawings, or approved samples.

Our products will only operate as well as the systems in which they are installed. We therefore expect the buyers of our products to be responsible for the proper design and fabrication of the systems in which our products are used. To assist our customers, we maintain a staff of sales engineers that can recommend the proper Lee Company products to satisfy a particular system requirement.

Should any Lee Company product not satisfy this warranty, we will promptly repair or replace it within a four (4) year period or the product's published cycle life, whichever is less, without responsibility for indirect or consequential damages, provided the product was used for its intended purpose, and in its intended environment.



## **DIRECTORY OF TECHNICAL PUBLICATIONS**

### **PROCESS SPECIFICATIONS**

- P.S. 187 *Installation and Extraction of Lee Inserts*
- P.S. 203 *Installation and Extraction of Lee Plugs*
- P.S. P1013 *AFO Plug Installation Procedure*
- P.S. J2374 *Installation of Lee 3-Ports Inserts*
- P.S. P1186 *Lee Solenoid Valve Installation Guide*
- P.S. T1011 *Lee Solenoid Valve Installation Guide:  
3-way Hi-Flow*
- P.S. P1205 *MultiSeal® Replacement and Reuse  
Procedure for 3000-PSI Lee Solenoid Valves*

### **OTHER PUBLICATIONS**

- Electro-Fluidic Systems Technical Handbook
- New Product Data Sheets

### **LEE LOHMOLATOR SLIDE RULE**

- Hydraulic and Pneumatic Flow Calculator – Solves basic  
Lohm calculations

### **LEE ENGINEERING CALCULATIONS SOFTWARE**

- Boss Stress Calculations
- Liquid & Gas Flow Calculations

NOTE: All technical publications are provided free of charge upon request as a service to our customers.



## I

## INDEX

## A

- ACFM ..... O37\*
- Absolute Viscosity,  
Definition ..... O85
- Accumulator  
Graphic Symbol ..... O81
- Actuator  
Graphic Symbol ..... O81  
Landing Gear ..... G3  
Unequal Area ..... G4
- A.F.O. Plug  
Features of ..... A17, A56-A59  
Installation ..... N21-N22
- Attenuation,  
Pressure Ripple ..... M3-M6
- Axial Visco Jet ..... B5,  
..... B34-B41, L13-L14

## B

- Ball Type Cheks ..... E3, E6-E17
- Bender Jet  
High Pressure ..... B12, B60-B69  
Insert ..... B5, B32-B33  
Line Mount ..... L6-L8, L21, L25, L29
- Boss Mount  
Safety Screen ..... I46-I57, I86-I107
- Boss Size ..... See Boss Stress
- Boss Stress  
Inserts ..... N24  
Plugs ..... A7-A14  
Software  
for calculations ..... O91
- Bulk Modulus  
Definition ..... O24  
Entrained Air  
effects of ..... O28  
Pressure, effects of ..... O27  
Temp., effects of ..... O27
- Burst Pressure ..... See Pressure Rating

## C

- CTFE  
Bulk Modulus ..... O24  
Coefficient of  
Thermal Expansion ..... O24

- Specific Gravity ..... O16-O17  
Specific Heat ..... O20  
Viscosity ..... O14-O15
- Cartridge Visco Jets ..... B48-B51
- Cavitation ..... B9-B10, O29
- Check Valves  
Ball Type Cheks ..... E3, E6-E17  
Features of ..... E3-E5  
Graphic Symbol ..... O83  
Hi-Q Cheks ..... E4, E38-E45  
High Pressure ..... E4, E58-E77  
Line Mount ..... L6-L12,  
..... L18-L19, L34-L45  
Lo-Lohm ..... E4, E30-E41  
NACE Compliant ..... E5, E78-E79  
Pilot Operated Cheks ..... E4,  
..... E70-E71  
Side Exit Cheks ..... E3, E18-E25  
Zero Leak Cheks ..... E4, E46-E57
- Coefficient of  
Thermal Expansion ..... O24
- Constant K  
Liquid Flow (Lohm Formula)  
..... O9-O12  
Gas Flow (Lohm Formula)  
..... O30-O33
- Contamination  
Control of ..... O58  
Levels ..... O59
- Control Valves  
Graphic Symbols ..... O83
- Conversion Chart  
Pressure ..... O79  
Temperature ..... O76  
Torque ..... O78  
Viscosity ..... O77
- Conversion Factors  
ACFM to SCFM ..... O37  
Mass ..... O71  
Mass to Volume - H<sub>2</sub>O ..... O75  
Pressure ..... O73  
Volume ..... O72  
Volume to Mass - H<sub>2</sub>O ..... O74
- Conversions ..... O70-O71
- Copyrights ..... O90
- Cross-Port Relief ..... F11\*

\* Topic briefly discussed  
on related subject

**D**

## Dampers

*Hydamp* ..... M6, M10-M11  
*Micro Damp* ..... M3-M5, M8-M9

## Definitions

*Absolute Viscosity* ..... O85  
*Bulk Modulus* ..... O24  
*Engler Degrees* ..... O85  
*Kinematic Viscosity* ..... O85  
*Lohm Laws* ..... O3  
*Saybolt-Furol* ..... O85  
*Saybolt Universal*  
*Seconds (SSU)* ..... O85  
*Viscosity Index* ..... O85  
*Viscosity Numbers* ..... O85

## Directional Flow Control

*High Pressure* ..... C16-C25  
*Insert* ..... C8-C15  
*Line Mount* ..... L6-L12, L46-L51

## Directory

*Technical Publications* ..... O91

## Dual Insert Adapter.....N25

**E**

## Elongation.....A7

## Engineering Capabilities

The Lee Company.....V

## Engler Degrees, Definition of.....O85

## Entrained Air.....O28

## Extraction

*Procedures* ..... See *Installation*  
*Threads* ..... N28

**F**

## Filters

*Graphic Symbols* ..... O81  
*Safety* ..... See *Safety Screens*  
*System* ..... O58

## 5k Lee Jet.....B52-B55

## Flange Mount

*Safety Screen*.....I24-I41, I68-I77

## Flostret

*Insert* ..... C5, C26-C29  
*Line Mount* ..... L9-L12

Flow Calculations.....See *Lohm Laws*

## Flow Coefficient .....O5

## Flow Controls

*Directional* ..... C4, C8-C15  
*High Pressure* ..... C16-C25  
*Line Mount* ..... L6-L12, L46-L51  
*Pressure Compensated* .... C26-C29  
*Principle of* ..... C3-C5  
*Restrictor Chek* ..... C3, C6-C7

## Flow Lines

*Graphic Symbols*.....O80

## Flushness Tolerance

*Inserts*.....N27  
*Plugs*.....N5

**G**

## Gallon Conversion

## Factors

*From Mass of Water* ..... O75  
*To Mass of Water* ..... O74  
*To Other Units* ..... O72

## Gas

*Flow Calculation* ..... O30-O45  
*Pneumatic Power* ..... O50-O51  
*Transient Flow* ..... O46-O47

## Gasoline

*Bulk Modulus* ..... O25  
*Coefficient of*  
*Thermal Expansion* ..... O25  
*Flash Point* ..... O25  
*Pour Point* ..... O25  
*Specific Gravity* ..... O16-O17  
*Specific Heat* ..... O20  
*Viscosity* ..... O14-O15

## Graphic Symbols.....O80-O83

# III INDEX

## H

Heat Exchanger  
Graphic Symbol.....O81

High Pressure  
*Cheks* ..... E4, E58-E77  
*Flow Controls* ..... C16-C25  
*Hi-Bar Safety Screens* ..... I74-I138  
*Hydamp* ..... M6, M10-M11  
*Plugs* ..... A64-A67  
*PRI* ..... F3-F6, F24-F30  
*Relief Valves* ..... F3-F7, F24-F30,  
..... F30-F33  
*Restrictors* ..... B12, B52-B69  
*Safety Screens* ..... I74-I138

High Strength  
*Plugs* ..... A64-A67  
*Safety Screens* ..... I74-I138  
*Hi-Bar Safety Screens*..... I74-I138

High Watt Jet  
*High Pressure* ..... B56-B59  
*Insert* ..... B4, B24-B25  
*Line Mount* ..... L6-L8, L25, L29

Hi-Q Cheks ..... E4, E38-E45  
*Line Mount* ..... L18-L19

Hole Diameter  
vs Lohms ..... O4

Hole Tolerance (plugs)..... A5

Hydamp ..... M6, M10-M11

Hydraulic Power..... O18-O19

## I

ISO 4406 ..... O60\*

Identification  
Component..... See *Marking*

Inserts  
*Check Valves* ..... E3-E7  
*Floserts* ..... C5  
*Flow Controls* ..... C2-C5  
*Installation of* ..... N26-N30  
*Nozzles* ..... D2-D3  
*Relief Valves* ..... F3-F12  
*Restrictors* ..... B3-B15  
*Shuttle Valves* ..... G2-G5  
*Three Port* ..... G2-G3

Inspection (plugs) ..... N3

Installation  
*Forces* ..... N5  
*Inserts* ..... N26-N30  
*Kipster* ..... N41  
*MicroJet* ..... N37  
*Plugs* ..... N4-N5  
*Safety Screens* ..... N38-N40  
*Visco Jets Cartridge* ..... N33-N36

Interflow ..... G2\*

Intermediate Pressure  
(between 2 Restrictors) ..... O40

## J

JP-4  
*Bulk Modulus* ..... O25  
*Coefficient of*  
*Thermal Expansion* ..... O25  
*Specific Gravity* ..... O16-O17  
*Specific Heat* ..... O20  
*Viscosity* ..... O14-O15

Jet (Lee)  
*Bender Jet* ..... B5, B32-B33  
*5K Lee Jet* ..... B12, B52-B55  
*High Watt Jet* ..... B4, B24-B25  
*Insert* ..... B4, B16-B23  
*Kilowatt Jet* ..... B4, B26-B27  
*Lee MicroJet* ..... B4, B28-B31  
*Line Mount* ..... L6-L8

## K

K Constant  
*Liquid Flow (Lohm Formula)*  
..... O9-O12  
*Gas Flow (Lohm Formula)*  
..... O30-O33

Kilowatt Jet ..... B4, B26-B27

Kinematic Viscosity,  
Definition of ..... O85

Kipster ..... M6-M7, M12-M13

\* Topic briefly discussed  
on related subject

## L

- L-4 Safety Screen ..... I66-I69
- Landing Gear,
  - Components for ..... G2-G3
- Line Mount
  - Axial Visco Jets* ..... L13-L14
  - Hi-Q Chek Valve* ..... L18-L19
  - Inserts in Unions* ..... L6-L12
  - Ring Locked Adaptors, Components in* ..... L20-L51
  - Visco Jets, Cartridge type* ..... L15-L17
- Liter Conversion Factors
  - From Mass to Water* ..... O75
  - To Mass of Water* ..... O74
  - To other units* ..... O72
- Liquid Flow ..... See *Lohm Laws*
- Lohm Laws
  - Constant K
    - Liquid Flow (Lohm Formula)* ..... O9-O12
    - Gas Flow (Lohm Formula)* ..... O30-O33
  - Definition of* ..... O3
  - Gas Flow* ..... O30-O52
  - Group Resistance* ..... O7-O8
  - Hydraulic Power* ..... O18-O19
  - Liquid Flow* ..... O5-O17
  - Momentum Forces* ..... O22, O45
  - Parallel Flow* ..... O7
  - Pneumatic Power* ..... O50-O51
  - Series Flow* ..... O7-O8
  - Snubbing* ..... M4
  - Software for* ..... O91

## M

- Marking, Component ..... O86
- Mass Conversion Factors ..... O71
- Master Sets ..... B13-B14
- Materials Plugs ..... A4-A5
- Metric
  - Dimensions of Inserts* ..... O84
  - Dimensions of Plugs* ..... N16
  - Plugs* ..... A38-A49
- Micro Damp ..... See *Dampers*
- MicroJet ..... B4, B28-B31

- MIL-H-83282 Fluid
  - Bulk Modulus* ..... O24-O25
  - Coefficient of Thermal Expansion* ..... O24-O25
  - Specific Gravity* ..... O16-O17
  - Specific Heat* ..... O20
  - Viscosity* ..... O14-O15
- Military Specs
  - MIL-A-8625* ..... A5\*
  - MIL-F-85720* ..... L3\*
  - MIL-H-5440* ..... M3\*
  - MIL-S-5002* ..... A5\*
  - MIL-V-19068* ..... G2
  - MS33514* ..... L3\*
- Minimum Passage
  - Inserts* ..... O58\*
  - Restrictors* ..... B15
- Momentum Forces
  - Gas* ..... O45
  - Liquid* ..... O22
- Momentum Pri ..... F5-F6, F34-F37
- Monel Plugs ..... A4\*, A34-A37
- Motors, Graphic Symbol ..... O82
- Multi-Orifice
  - Restrictors* ..... B5, B12, B32-B51, B60-B77

## N

- NACE Compliant Products ..... A58-A59, B66-B67, C36-C40, E78-E79, F30-F31, I84-I85
- NAS 1638 ..... O60-O61
- Nomogram, Lee Tri Flow ..... F9
- Nozzles
  - Lubrication Jet* ..... D6-D17
  - Principle* ..... D2-D3
  - Spin Jet* ..... D4-D5

\* Topic briefly discussed on related subject

## V

## INDEX

## O

- One-Way Restrictor
  - See Directional Flow Control*
- Orifice ..... *See Restrictors*
- Oversize
  - Inserts ..... N27-N30
  - Plugs ..... N9, N10-N13, N20

## P

- Pri ..... *See Relief Valve*
- Patents.....O90
- Peak Pressure
  - Recorders.....*See Kipster*
- Pilot Operated Cheks .... E5, E80-E87
- Pilot-Operated Checks,
  - Graphic Symbol.....O83
- Piloting Solenoid Valve .....J1-J39
- Pin Jacking Tool.....N29
- Plug Jets.....A67
- Plugs
  - A.F.O. .... A56-A63
  - Boss Stress ..... A7-A14
  - Certificate of
    - Performance .....N3
  - Color Code .....N3
  - Elongation .....A7
  - Flushness Tolerance .....N5
  - High Strength ..... A64-A67
  - Hole Tolerance .....A5\*
  - Installation Tools .....N4
  - Metric ..... A38-A49
  - Principle of .....A3
  - Proof Pressure .....A5
- Quick Installation ..... A16, A32-A33
- R.F.O. .... A50-A55
- Stress Corrosion .....A14-A15
- Surface Treatment of Holes ..... A5
- Pneumatic Power.....O50-O51
- Pressure
  - Conversion Chart .....O79
  - Conversion Factors .....O73
  - Damping ..... *See Dampers*
  - Effect on Bulk Modulus .....O27

- Measurement.....*See Kipster*
- Reducing Valve
  - Graphic Symbol .....O83
- Raising Valve ...*See Relief Valves*
- Ratings .....O63-O69
- Recorder .....*See Kipster*
- Relief .....*See Relief Valves*
- Switch
  - Graphic Symbol .....O83
- Transients ..... *See Dampers*
- See Pressure Ratings*

- Pressure Compensated
  - Flow Control ..... *See Flosert*
- Pressure Ratings
  - Flow Control Valves.....O68
  - Government/Industry
    - Standards .....O64
  - Lee Chek and
    - Relief Valves .....O66-O67
  - Restrictors.....O65
  - Standard Line Mount .....O69
  - Standard Shuttle Valves .....O68
- Process Specification .....O91
- Proof Pressure .....
  - See Pressure Ratings*
- Proprietary Rights.....O87
- Publications (Directory).....O91
- Pulsation Damper ..... *See Dampers*
- Pumps, Graphic Symbol .....O82

## Q

- Quality Assurance..... VI
- Quick Disconnect
  - Graphic Symbol.....O83
- Quick Installation
  - Plug (QIP) ..... A32-A33

## R

- R.F.O. Plug
  - Features of ..... A16, A50-A55
  - Installation .....N17-N20
- Registered Trademarks
  - See Trademarks* .....O88-O89
- Reinstallation
  - L-4 Safety Screen ..... L36
  - Inserts ..... L24
  - Plugs ..... L6\*
  - 3-Port Inserts ..... N31-N32

\* Topic briefly discussed  
on related subject

- Relief Valves
  - Cross-Port .....F11
  - Features of .....F2-F7
  - Graphic Symbol .....O83
  - Hi-Lohm .....F2-F3, F30-F31
  - High Pressure ...F3-F4, F30-F33
  - Line Mount .....L6-L12
  - Low Flow .....F2-F3, F30-F31
  - Low Pressure .....F2-F6
  - Momentum Free .....F3, F34-F37
  - Pressure Raising .....F6
  - Safety Relief .....F2-F6
  - Thermal Relief .....F4, F40-F43
- Removal..... *See Extraction*
- Restrictor Chek..... C3, C6-C7
- Restrictors
  - Axial Visco Jet .....B5,
    - .....B34-B41, L13-L14
  - Bender Jet .....B5, B12,
    - .....B32-B33, B60-B69
  - Graphic Symbol .....O82
  - High Pressure .....B12, B52-B69
  - High Watt Jet .....B4, B12,
    - .....B24-B25, B56-B59
  - Jet (Lee) .....B4, B16-B23
  - JEVA .....B5, B42-B45
  - One-Way .....C3-C4, C8-C25
  - Master Sets .....B13-B14
  - Summary Chart .....B15
  - Visco Jet .....B6, B12,
    - .....B46-B51, B70-B73, L15-L17
- Ripple, Pressure
  - Attenuation of .....M3-M6
- ROV Numbers.....I3-I7, O53-O57
  - Definition of.....O53
- Ring Locked Adapters,
  - Lee Products in.....L20-L51
  
- S**
- SAE Specs.
  - AS 4059 .....O61\*
- Safety Relief .....*See Relief Valves*
- Safety Screens
  - Boss Access .....I21
  - Boss Mount .....I18,
    - .....I46-I57, I86-I107
- Clogging .....H9
- Construction Method
  - Etched .....I15-I16
  - Drilled .....I17
- Filters vs. Safety Screens .....I8
- Flange Mount .....I18
  - .....I24-I41, I74-I85
- Graphic Symbol .....O81
- HI-BAR .....I74-I138
- HI-BAR Boss Access.....I108-I113
- Hole Sizes .....I12
- Insert .....I19, I58-I65
- L-4 .....I19, I66-I69
- In Ring Locked Adapters and
  - Straight Thread Adapters ...I21,
    - .....I114-I138
- Pressure Rating .....I10-I11
- Relative Rating System .....I3-I7
- Special Products .....I139-I140
- Spring Retained .....I20, I70-I73
- TWIS .....I20, I73
- Saybolt-Furol, Definition.....O85
- Saybolt Universal
  - Seconds, Definition .....O85
- SCFM .....O37
- Screens ..... *See Safety Screens*
- Selector Valve,
  - Graphic Symbol.....O83
- Servo Valve,
  - Graphic Symbol.....O83
- Shuttle Valve
  - Detented .....G22-G23
  - Graphic Symbol .....O83
  - Inverse .....G4-G5, G42-G45
  - Landing Gear, Components for
    - .....G2-G3
  - High Pressure Spring Biased
    - .....G14-G21
  - Overview .....G2
  - Selective .....G34-G41
  - Spring Biased .....G4, G6-G13
- Side Exit Cheks .....E3, E18-E25
- Skydrol
  - Bulk Modulus .....O25

\* Topic briefly discussed on related subject

# VII INDEX

*Coefficient of*  
  *Thermal Expansion* .....O25  
*Flash Point* .....O25  
*Pour Point* .....O25  
*Specific Gravity* .....O16-O17  
*Specific Heat* .....O20  
*Viscosity* .....O14-O15

Snubbers ..... *See Dampers*

Software .....O91

Solenoid Valves, Piloting.....J1-J39

Specially Fabricated  
  Components.....VII, O87

Specific Gravity  
  vs Temperature.....O16-O17

Specific Heat .....O20

Specifications  
  *Military* ..... *See Military Specs*  
  *Process* .....O91  
  *SAE* .....*See SAE Specs*

Spring Retained Safety Screen .....  
  .....I20, I70-I73

Standards, Primary.....O70

Stress, Boss .....*See Boss Stress*

Stress Corrosion .....A14

Surface Treatment of  
  Installation Holes.....A5

Symbols, Graphic .....O80-O83

System Filter .....O58\*

## T

Technical Publications .....O91

Temperature  
  *Conversion Chart* .....O76  
  *Effects on Bulk Modulus* .....O27

Temperature Rise in  
  Hydraulic Fluids  
    *Calculation* .....O20  
    *Nomogram* .....O21

Thermal Relief Valve.....F6-F7,  
  .....F40-F43

Threads, Extraction.....N28

Three Port Inserts  
  *Installation of* .....N31-N32  
  *Shuttle Valve* .....G1-G45

Tolerance  
  *Flushness* ..... *See Flushness Tol.*  
  *Hole* ..... *See Hole Tolerance*

Tools ..... *See Section N*

Torque Conversion  
  Chart .....O78

Trademarks.....O88-O89

Transducer, Pressure  
  Damping.....M3-M5  
  Graphic Symbol .....O83

Transient Gas Flow.....O46-O47

Transients, Pressure  
  Dampers .....M3-M6  
  Ratings.....O63-O69

TWIS Safety Screen .....I20, I73

## U

Unions .....L3, L6-L12  
  ..... *See Line Mounts*  
  ..... *See Ring Locked Adapters*  
  ..... *(Lee Products in)*

## V

Valves  
  *Graphic Symbol* .....O83  
  *Check (Chek)* .....E3-E5  
  *Relief (Pri)* .....F2-F11  
  *Thermal (Tri)* .....F2, F6-F9  
  *Shuttle* .....G2-G5

Visco Jet  
  *Axial* .....B5, B34-B41  
  *Cartridge* .....B5, B48-B51  
  *Insert* .....B5, B12, B34-B41,  
    .....B46-B47, B70-B73  
  *Line Mount* .....L6-L8,  
    .....L13-L17, L20-L28  
  *Principle of* .....B6-B12  
  *Snubber* .....M3-M5, M8-M9

Viscosity  
  *Conversion Chart* .....O77  
  *Compensation Factor* .....O13  
  *Index* .....O85  
  *Numbers* .....O85  
  *vs Temperature* .....O14-O15

Volume Conversion  
  Factors.....O72

## W, X, Y, Z

Warranty .....	O90
Water	
<i>Bulk Modulus</i> .....	O25
<i>Coefficient of</i>	
<i>Thermal Expansion</i> .....	O25
<i>Conversion Factors,</i>	
<i>Mass to Volume</i> .....	O75
<i>Conversion Factors,</i>	
<i>Volume to Mass</i> .....	O74
<i>Pour Point</i> .....	O25
<i>Specific Gravity</i> .....	O16-O17
<i>Specific Heat</i> .....	O20
<i>Viscosity</i> .....	O14-O15
Water Hammer .....	O23
Wax (on pins).....	N3
Zero Leak Cheks .....	E4, E46-E57





Innovation in Miniature  
**LEE**   
The Lee Company

2 Pettipaug Road, P. O. Box 424  
Westbrook, Connecticut 06498-0424 USA

860 399-6281  
800 LEEPLUG (800 533-7584)

[www.theleeco.com](http://www.theleeco.com)